

# PIXEL 9

14W

## OUTDOOR DIRECT-VIEW LED NODE FOR SMALL AND LARGE-SCALE APPLICATIONS

### DESCRIPTION

The Pixel Series of luminaires are high-output compact LED nodes designed for decorative outdoor applications.

The Pixel 9 is powered by nine Luxeon Rebel LEDs, and is available in single colour, warm/cool white, RGB colour-changing or custom-configurations.

Perfect for accentuating architectural features in large-scale pixel-mapping applications, it's equally suited for small to medium decorative projects and is available in surface-mount or catenary-mount.

Fully dimmable with integral DMX and RDM for remote address-setting and diagnostics, the Pixel 9 is the perfect choice for special effect and architectural feature lighting.

### FEATURES

**GORE® Vent** Waterproof membrane that allows the luminaire to breathe with changing environmental conditions whilst preventing dust and moisture ingress.

**Housing** Anodised aluminium, custom colours available\* (black finish was customised for the AAMI Park project).

**Cable** Combined UV-stabilised low-voltage power/data cable with custom 5-pin in/out connectors for easy installation. Simply daisy-chain together.

**Diffuser** Shock and UV-resistant cover that allows 180 degree viewing.

**Made in Melbourne, Australia.**



Pixel 9 (standard plug-and-play)



Pixel 9 (catenary)



Pixel 9 (wash)



IP  
66



AAMI Park Melbourne Australia  
Photo: Sandra Davis  
Courtesy MOPT

## SPECIFICATIONS

### Housing

Aluminium  
- anodised or powder-coated  
(custom colours available)

### Ingress Protection

IP66

### Control

DMX512, RDM  
(Remote Device Management)  
Onboard thermal management  
with RDM monitoring and  
current (brightness) reduction  
in the event of overheating.

### LEDs

9 x Lumileds Rebel LEDs  
(3 x red, 3 x green, 3 x royal  
blue)

### LED Optics

Diffuser dome.

### LED Colours

Single colour:  
Red, Green, Blue, Amber, Cool  
White, Warm White.  
Also available in variable white  
and variable colour (RGB).

### Power

24V DC  
Max. power: 14W

### Connections

IP66 combined power/data  
standard (hard-wire version  
also available)

### Accessories not included

DMX controller  
Custom brackets

### Weight

900g (standard with cables)  
1.04kg (catenary hard-wire  
version, no cables)

## DIMENSIONS

All dimensions in millimetres unless otherwise noted.

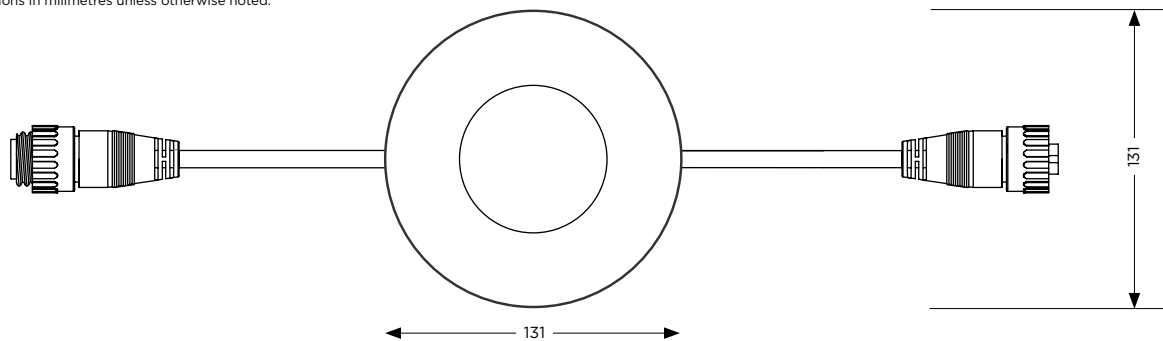

## STANDARD VERSION

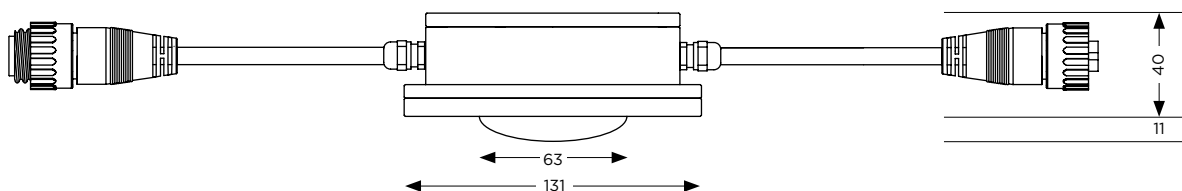

## CATENARY-MOUNT VERSION

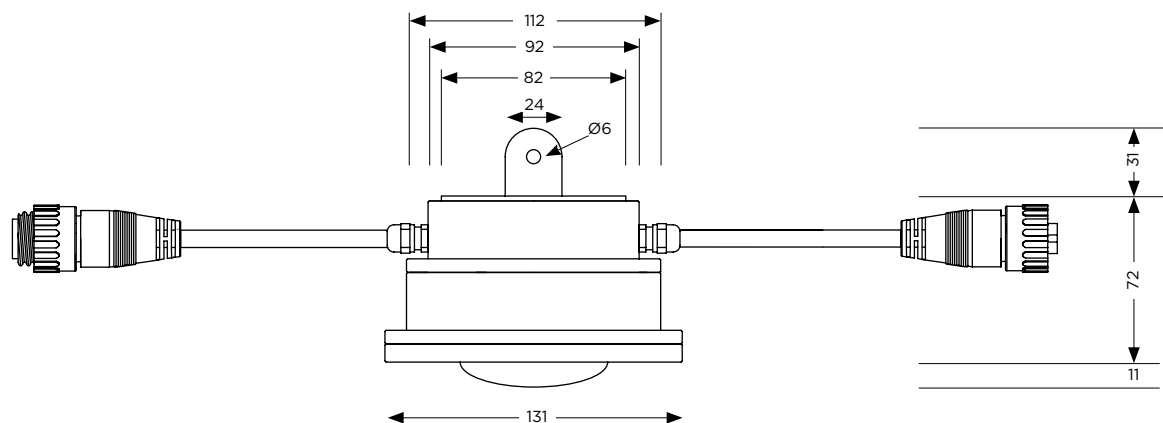

APPLICATION PHOTOS



Lonsdale Gateway Melbourne Australia  
Pixel Catenary-mount Version  
Photos: Casamento Photography