

PULSAR CHROMAFLOOD 100 ROUND DATASHEET

The ChromaFlood 100 Round is a high powered LED spot fixture ideal for architectural features, concerts and stage shows. In addition to full manual control of RGB levels, two integrated ChromaZone controllers enable stunning visual effects with or without an external lighting control system.



CFLD100RTC-B25
with single colour top hat in black

Features

- ③ 30 x 3W TriColour LEDs with 256 levels of controllable Red, Green, and Royal Blue giving 16.7M colours all pre-mixed within the fixture.
- ③ Continuous, smooth current through the LEDs giving flicker-free, soothing light.
- ③ 100,000+ hours of LED, component, and driver life.
- ③ Built-in Power Supply and Controller with two Effects Generators allows for remote DMX control or stand-alone use.
- ③ Waterproof to IP66 so suitable for both indoor and outdoor use.
- ③ A range of interchangeable lens plates allow for different beam angles in any application.

Applications

- ③ Building façades
- ③ Concerts and Television
- ③ Theatre and Stage
- ③ Themed Environments
- ③ Water Features
- ③ Decorative displays
- ③ Creative Installations

Supplied by:

lightmoves

Melbourne
03 9701 2500

Sydney
02 9737 8988

info@lightmoves.com.au

www.lightmoves.com.au



Pulsar Light of Cambridge Ltd

3 Coldhams Business Park, Norman Way, Cambridge CB1 3LH
www.pulsarlight.com | sales@pulsarlight.com | +44 (0) 1223 403 500

CHROMAFLOOD 100 ROUND DATASHEET

TECHNICAL SPECIFICATION

Light Source

LEDs 30 x 3W Red/Green/Royal Blue TriColour LEDs

Life LEDs and all components in our fixtures are chosen and driven to exceed a 100,000 hour design life.

Light Output 2,635 lm visible spectrum only. The fixture produces no infra-red or ultra-violet light which can heat or fade objects.

Beam Angles 8°, 25°, 45°, 10x35°, 10x90°, 90° (no lens) interchangeable lens plates

Flicker Free Continuous current ensures a smooth, flicker-free, soothing light. We will not compromise on this and we do not use Pulse Width Modulation (PWM) which strobes the LEDs at high frequency and can produce an agitating light.

Control

Colours 256 Levels of RGB ≈ 16.7M colours.

Sequences The built-in ChromaZone Effects Generator provides a wide range of 6-12 way chases and sequences for strunning lighting effects without complicated programming.

Control input DMX 512 to allow full remote control of intensity levels, or to select effects from the built-in ChromaZone Effects Generator.

LCD menu For quick fixture configuration allowing operation without a separate control system.

Electrical

Power 85-277 VAC, 100W max, 50-60Hz, self adjusting

Power Cable 5m (16.4') captive

Data In/Out 2 x 5-pin XLR (1 x M, 1 x F)

Data Cable 2 x 5m (16.4') captive

Physical

Finish Black, Silver, or White (special colours available on request).

Mounting The fixture can be floor, wall or truss mounted using the brackets

supplied. Once mounted the fixture can be adjusted to a selected angle.

Dimensions 295 (W) x 310 (H) x 215mm (D) (11.6 x 12.2 x 8.5")

Weight 5.5 kg (12.1 lbs)

Pack Dimensions 310 x 310 x 325mm (12.2 x 12.2 x 13.2")

Pack Weight 6.1 kg (13.4 lbs)

Operating Conditions

Temperature -20°C to +50°C

Cooling The fixture is convection cooled using the metal body as a substantial heatsink. Above a threshold temperature a thermal control system smoothly reduces the power to protect the LEDs and internal electronics from excessive temperatures.

Environment Wet conditions up to IP66

Product Options

Product Code CFLD[MSA]100R[T]-[F][B]
MSA: Stand Alone [blank] Standard fixture; MSA, Full On single colour fixture with no DMX control
T: LED Type TC, TriColour; [blank], RGB; VW, Variable White; UV, UltraViolet; SC, Single Colour
F: Body Finish B, Black; S, Silver; W, White
B: Beam Angle 8, 25, 45, 10x35, 10x90, 90 (no lens)

Additional Lens Plates

Product Code CFLD100R-[B]LP
B: Beam Angle 8, 25, 45, 10x35, 10x90, 90 (no lens)

Single Colour Top Hat

Product Code CFLD100RTH-[F]
F: Body Finish B, Black; S, Silver; W, White

Two Colour Top Hat: Black Inner, Custom Outer

Product Code CFLD100RTH-B[F]
F: Body Finish B, Black; S, Silver; W, White

Guarantee

3 years from the date of original purchase. The guarantee is limited to parts and labour. The Guarantee is void if the unit is misused, the cable connections are not in a dry environment, or unauthorised persons perform repairs. In the unlikely event of a fault occurring, do not use without repair. Return the unit to your supplier with a description of the fault, or direct to Pulsar for immediate attention.



PULSAR CHROMAFLOOD 100 ROUND DATASHEET

PHYSICAL DIMENSIONS

Top View

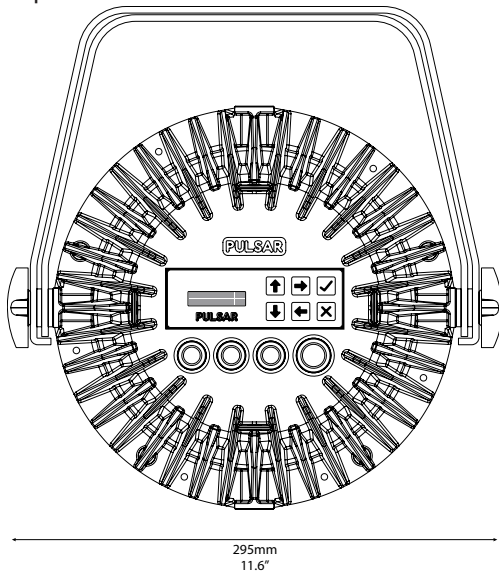

Side View

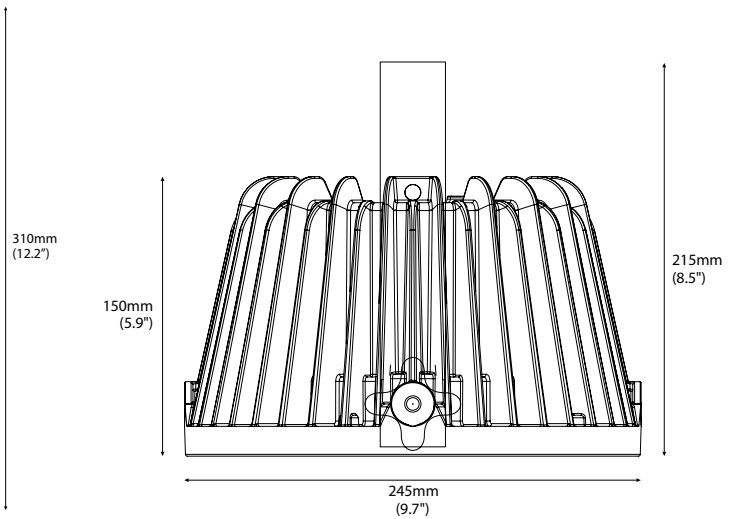

End View

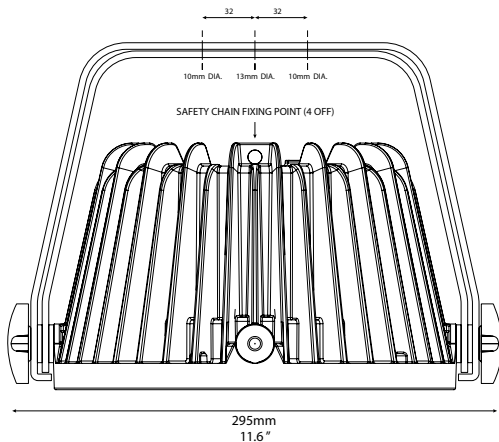

Lamp Matrix Dimnsions and
Perspective View

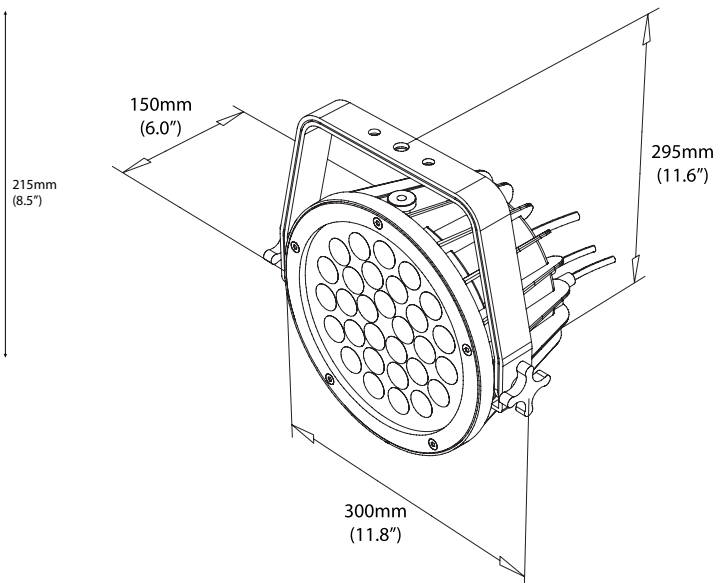

The Pulsar ChromaFlood 100 Round complies with the following International and National Standards:

Electrical Safety EN 60065
EMC EN 55022, EN 61000-6-1, EN 61000-6-3

Index of Protection IP66

EEC Directives Marking: 93/69/EEC
EMC: 2004/108/EEC
Low Voltage: 2006/95/EEC



Pulsar Light of Cambridge Ltd

3 Coldhams Business Park, Norman Way, Cambridge CB1 3LH
www.pulsarlight.com | sales@pulsarlight.com | +44 (0) 1223 403 500

CHROMAFLOOD 100 ROUND DATASHEET | 3
ISSUE DATE | JULY 2014

CHROMAFLOOD 100 ROUND DATASHEET

CONTROL AND SETUP

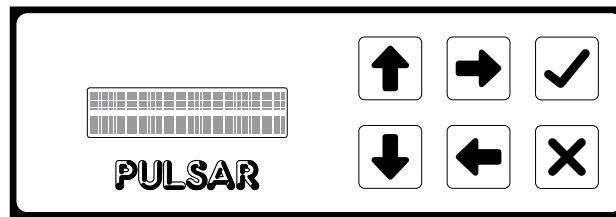

Essentials

The Pulsar ChromaFlood 100 Round is addressed and configured via the 6-key User Interface Module (UIM, illustrated above) on the reverse of the unit or via Pulsar Fixture Management and a Pulsar Fixture Manager One (PFMOne) remote over the DMX line.

Once set up, ChromaFlood 100 Round LED levels can be controlled by standard DMX signal from an external source. Alternatively, stand-alone settings can be specified from the UIM or PFMOne, allowing the fixture to operate without connection to an external DMX controller.

The ChromaFlood 100 Round also features an in-built ChromaZone which can be programmed to sequence the fixture through a wide range of colour changes and chases.

Two internal chases, with different effects and timings, may be run simultaneously to create a composite effect. For example, a rainbow wave could be superimposed on a gradual colour change.

A master dimmer channel (ch. 10) is provided for a fixture in 10 or 46 channel ChromaZone Mode. By default this dims only the 36 ChromaZone channels (ch. 11 - 46) but can be configured to act as a Grand Master for the 3 global RGB channels (ch. 1 - 3) and the global ChromaZone chase intensity channels (ch. 6 and 9).

Multi-Fixture ChromaZone Features

Using the integrated ChromaZone presets, groups of 12 ChromaFlood 100 Round units can be configured to play chases and sequences in synchrony without any interconnection required between the units.

To achieve a chase that appears to sweep across all of the fixtures, each unit is set with the same chase settings but a different Fixture Number is specified via the UIM/PFMOne. Applying power simultaneously to all the fixtures will then initiate the correct chase sequence timing.

Configurable Settings

The ChromaFlood 100 Round provides the following menus with their corresponding options:

- DMX Address: 1 - 512
- Channels per Fixture: 1 (SC), 2 (VW), 3 (TC)
- ChromaZone Mode*: 3/6/9/10/42/46 channels
- Fixture Number*: 1 - 12
- Chase patterns*: 6 Way/12 Way
- Channel 10 Grand Master (GM) options*
- Input Smoothing: Smooth/Fast
- Low Voltage Supply: On/Off
- DMX Line Termination: On/Off
- If NoSignal use: Stand Alone Mode/Last DMX packet
- Stand Alone Settings: View/Change
- View/Set Channel Levels
- Restore Factory Default Settings

Chase Options

The following predefined chases are provided:

- Auto chase
- Green yellow red bar graph forward/reverse
- Rainbow strobe
- White/any colour strobe
- White/any colour crossover
- Blue-yellow wave forward/reverse
- Green-magenta wave forward/reverse
- Red-cyan/any colour/opposite colour wave forward/reverse
- Black-white/any colour wave forward/reverse
- Random colours. Chase1 crossfades, chase2 snaps
- Rainbow 2 (wider primary colours) crossfade forward/reverse
- Rainbow crossfade forward/reverse
- Follow3 18 contrasting colours forward/reverse
- 18 crossfading colours forward/reverse
- White/any colour/auto colour cascade forward/reverse
- 6 crossfading pastel colours
- Colour wipes
- 6 crossfading colours
- 6 separate colours
- Red green blue bar graphs forward/reverse
- No chase

*TriColour versions only

CHROMAFLOOD 100 ROUND DATASHEET

ARCHITECTURAL SPECIFICATION

TriColour (TC) Overview

The product shall be a high power IP66 LED fixture that contains 30 x 3W Red/Green/Royal Blue TriColour LEDs, calibrated to produce white light and capable of projecting a wash of light in any colour by mixing the level of outputs from the Red, Green, and Royal Blue components.

Variable White (VW) Overview

The product shall be a high power IP66 LED fixture that contains 20 x 3W 6000K Cool White and 10 x 3W Amber LEDs, calibrated to produce white light of a variable colour temperature and capable of projecting a wash of light of any colour temperature by mixing the level of outputs from the Cool White and Amber components.

Single Colour (SC) Overview

The product shall be a high power IP66 LED fixture that contains 30 x 3W Single Colour LEDs, calibrated to produce a single colour and capable of projecting a wash of light of variable intensity by adjusting the level of output from the LED components.

Mains Stand Alone (MSA) Overview

The product shall be a high power IP66 LED fixture that contains 30 x 3W Single Colour LEDs, calibrated to produce a single colour and capable of projecting a wash of light of fixed intensity from the LED components.

Light Source

The product shall employ continuous drive electronics using direct current to the LEDs to produce a flicker-free, smooth, soothing light and shall not use PWM (Pulse Width Modulation).

The product shall be available with a range of integrated lenses to obtain beam angles of 8, 25, 45, 10 x 35, 10 x 90, or 90 degrees, and these should also be available as optional lens plates.

Control

The product shall incorporate two in-built effects generators that may be varied in chase type, pattern and speed.

The product shall allow control from a DMX source to enable the user to access the in-built programs and to

change the levels of the output.

The DMX connection shall be made by 2 x 5 metre trailing cables fitted with a 5-pin XLR plug and a 5-pin XLR socket.

The DMX input shall be protected from static and accidental connection to mains voltages, present only 1/20th of a unit load to the DMX line, and have a common mode range >200V.

The DMX start address shall be set by the User Interface Module. Data conditions shall also be displayed via the User Interface Module

Physical

The product shall be supplied with mounting brackets enabling it to be floor, wall or truss mounted, and adjusted to a selected angle.

Electrical

The product shall possess a 100W switched-mode power supply that features automatic voltage selection for the electronics between 85-277 volts AC and between 50-60Hz.

The product shall provide a mains voltage connection via a single 5 metre trailing cable.

Combined Power and DMX Cable Option

The product shall provide mains voltage connection and DMX connection via one 0.75 metre trailing cable fitted with a 8-pin plug and shall be capable of interconnecting with additional LED devices via a second 0.75 metre trailing cable fitted with a 8-pin connector.

Operating Conditions

The product shall be capable of operating in an ambient temperature range of -20°C to 50°C.

The product shall be convection cooled using the body of the product as a substantial heatsink. Above a threshold temperature, a thermal management control system shall smoothly reduce the power to protect the LEDs and the internal electronics from excessive temperatures.

The product enclosure shall be rated with the IP rating of IP66.

PULSAR
**CHROMAFLOOD 100 ROUND
DATASHEET**

NOTES



Pulsar Light of Cambridge Ltd

3 Coldhams Business Park, Norman Way, Cambridge CB1 3LH
www.pulsarlight.com | sales@pulsarlight.com | +44 (0) 1223 403 500

CHROMAFLOOD 100 ROUND DATASHEET | 6
ISSUE DATE | JULY 2014

PULSAR
**CHROMAFLOOD 100 ROUND
DATASHEET**

NOTES

