



# PATPA

AntumbraTouch American

Contemporary smooth glass panels with capacitive touch technology

The Philips AntumbraTouch user interface has a smooth glass finish with capacitive touch technology to detect button presses. It also incorporates the latest in field effect technology to sense a person's presence. The contemporary design features a number of button configurations, with each button capable of local or site-wide control functions. The PATPA range is suitable for, but not limited to, North American, South American, Australian and New Zealand markets.

Supplied by:

The Lightmoves logo, featuring the word 'lightmoves' in white with a colorful rainbow arc over the 'o', and the tagline 'illuminating ideas' below it. Contact information for Melbourne and Sydney is provided, along with an email address and website URL.

**Melbourne**      **Sydney**  
03 9701 2500      02 9737 8988  
info@lightmoves.com.au  
www.lightmoves.com.au

# PATPA

## Contemporary smooth glass panels with capacitive touch technology

- **Field effect technology\*** – The user interface detects an approaching user and ‘wakes up’, initiating a wall-wash lighting effect to encourage interaction.
- **Capacitive touch technology** – Smooth glass finish detects the presence of a finger and triggers a button press action.
- **Supplied as two components** – The Application Module contains buttons, rim, base and mounting plate, which can be mixed and matched to suit décor. The Communication Module contains all of the logical and network functions and is pre-programmed off-site, allowing commissioning to commence prior to finish options being finalized.
- **Hidden sensory inputs** – An internal light sensor measures ambient light and adjusts lightwash effect accordingly. A built-in temperature sensor automatically adjusts air conditioning when integrated into the system.
- **Multiple language and icon labeling** – Button labeling language choices include English, Chinese and Arabic. A library of common icons transcends language barriers, which is particularly useful in hospitality applications.
- **Décor-matching options** – Rims are available in aluminum, black, chrome and white. Fascia finishes include magnesium, silver and white.

---

## Dimensions

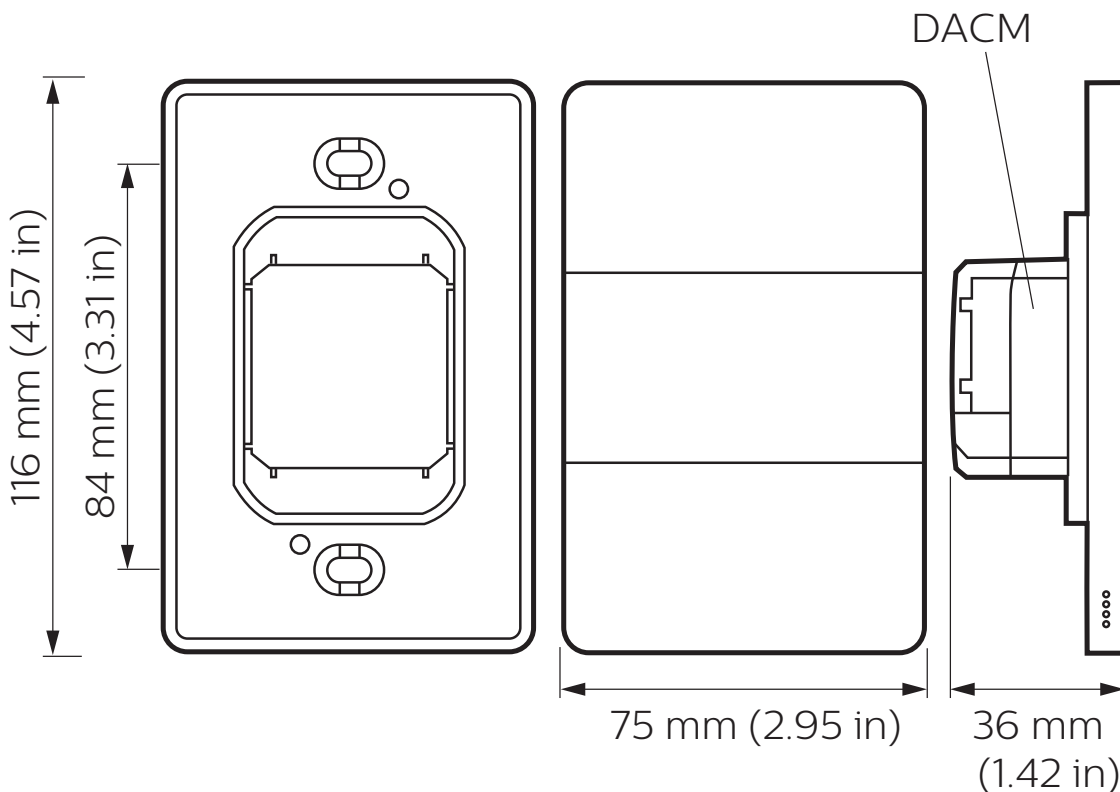

\* The mounting plate must be grounded to avoid field effect false triggering by nearby ungrounded metal objects.

# Specifications

Due to continuous improvements and innovations, specifications may change without notice.



**PATPA**  
AntumbraTouch American

## Electrical

Supply Type	DyNet
Supply Voltage	12-24 VDC SELV/Class 2
Supply Current	40 mA @ 12 VDC 25 mA @ 24 VDC

## Application Module

User Inputs	6 x software-configurable buttons
Indicators	White indicator LED on each button White wall-wash backlight
Temperature Sensor Range	5° to 40°C (41° to 104°F)
Temperature Sensor Accuracy	± 1.5°C (± 2.7°F)
Field Effect Detection Range	approx. 15 cm (6 in)

## Communication Module

Serial Ports	1 x RS-485
Supported Protocols	DyNet
User Inputs	1 x service switch
Indicators	1 x service LED

## Physical

Dimensions (H x W x D)	116 x 75 x 36 mm (4.57 x 2.95 x 1.42 in) (fully assembled)
Packed Weight (application module)	0.19 kg (0.42 lb)
Packed Weight (communication module)	0.12 kg (0.25 lb)
Fascia/Rim Finish	See Page 4
Serial Ports	1 x 5-way pluggable screw terminal +V, D-, D+, GND, SHLD
Serial Port Conductor Size	2.5 mm <sup>2</sup> (#12 AWG) (max)

## Environment

Operating Temperature	-5° to 50°C ambient (23° to 122°F)
Storage/Transport Temperature	-25° to 60°C ambient (-13° to 140°F)
Humidity	0 to 90% non-condensing
IEC Pollution Degree	II

## Compliance

Certification	CE, RCM, FCC, ICES, RoHS
IP Rating	IP22



# AntumbraTouchPanel Assembly

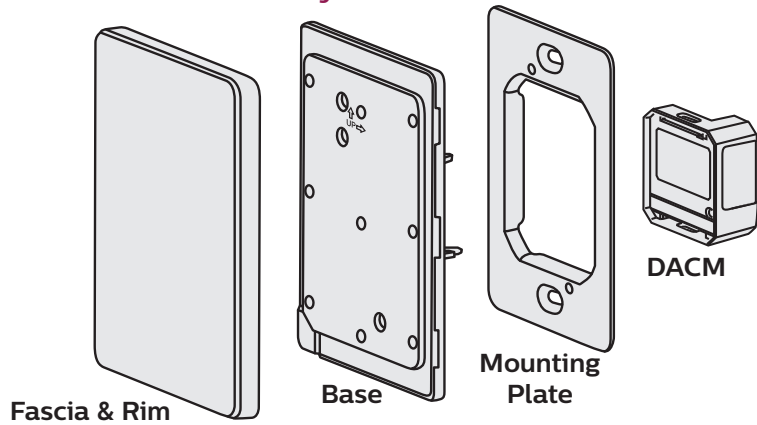

## Application Module Ordering Code

The Application Module contains the fascia, rim, base and mounting plate. The fascia and rim are available in the range of finishes shown below.

The base contains all the sensors and LED indicators. Sensitive components are enclosed by a rubber envelope to give an IP22 rating, allowing installation in high-condensation environments such as bathrooms.

A metal mounting plate attaches the Antumbra panel securely to the wall, ensuring stable, reliable operation.



# PATPA-WC-X

### Fascia Finish

B = Black

S = Silver

W = White

### Rim Finish

A = Aluminum

B = Black

C = Chrome

W = White

### Button Labeling

L = Labeling

X = No labeling

## Communication Module Ordering Code

The Communication Module is compatible with all interfaces across the Antumbra series, and can be ordered, programmed, installed, wired and tested without the Application Module attached.

This allows the commissioning process to begin before the final finish options have been chosen, or during construction, and protects the Application Module from damage until the site is ready for occupancy.



### Product

DACM-DyNet (DyNet communication module)

### Philips 12NC

913703970707

### Accessories

DINGUS-DUS-RJ12-DUAL (Dual RJ12 serial adaptor)

913703064309

DINGUS-DUS-RJ45-DUAL (Dual RJ45 serial adaptor)

913703064409

