



## Installation Instructions

Instructions d'installation  
Installationsanweisungen  
Instrucciones de instalación  
Istruzioni per l'installazione  
Installatie-instructies  
インストール手順  
安裝指示  
إرشادات التركيب

**⚡ Devices must be installed by a qualified electrician in accordance with all national and local electrical and construction codes and regulations.**

Les appareils doivent être installés par un électricien diplômé conformément à tous les codes et réglementations électriques et de construction nationaux et locaux.

Die Geräte sind von einem qualifizierten Elektriker in Übereinstimmung mit allen geltenden Vorschriften zu installieren.

Los dispositivos deben ser instalados por un electricista calificado y cumpliendo todas las normas y regulaciones, tanto nacionales como locales, sobre instalaciones eléctricas y obras.

I dispositivi devono essere installati da un elettricista qualificato in conformità con le norme locali e nazionali vigenti in materia di costruzioni edilizie e installazione di impianti elettrici.

De apparaten moeten worden aangebracht door een gekwalificeerde elektricien en in overeenstemming met alle nationale en plaatselijke elektriciteits- en bouwvoorschriften.

装置を取り付ける際は、資格のある電気技師に依頼し、国および地域の電気および建設に関するすべての法令に従ってください。

根据国家/地区及当地的电气与建筑规范和法规，该设备必须由有资质的电工进行安装。

يجب تركيب الأجهزة من قبل فني كهربائي مؤهل وفقاً لكافة قوانين ولوائح التركيب الكهربائي المحلي والوطني.

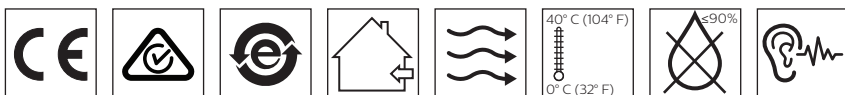
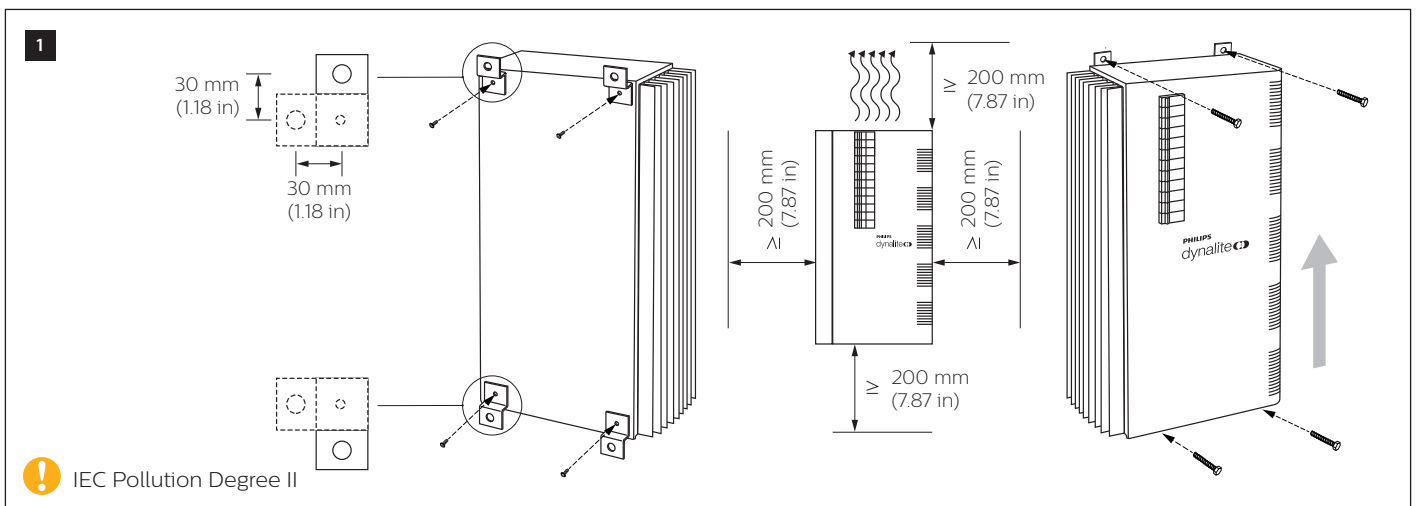
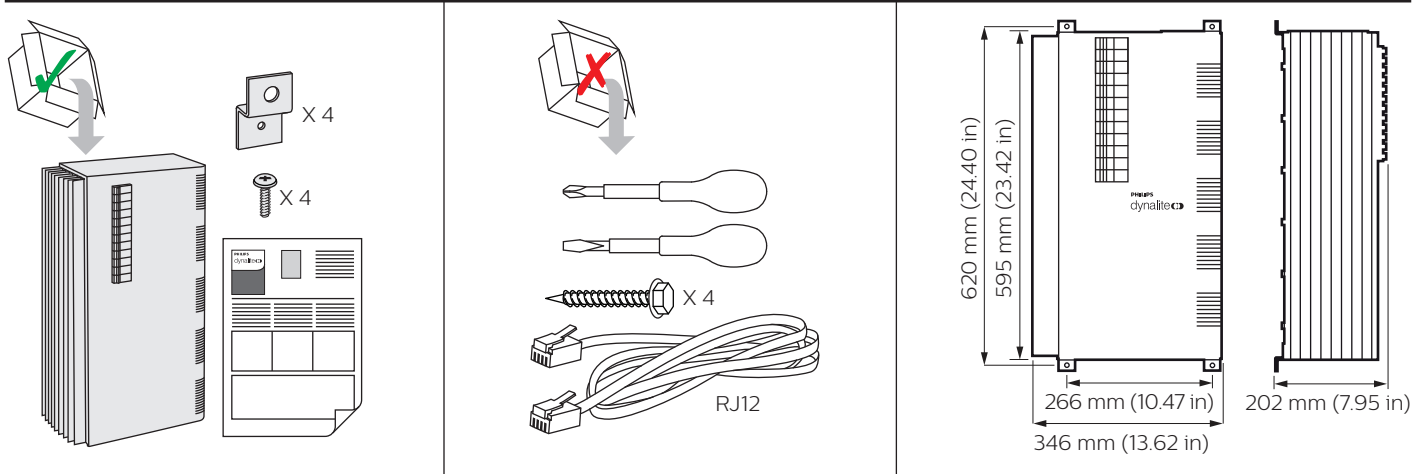

2

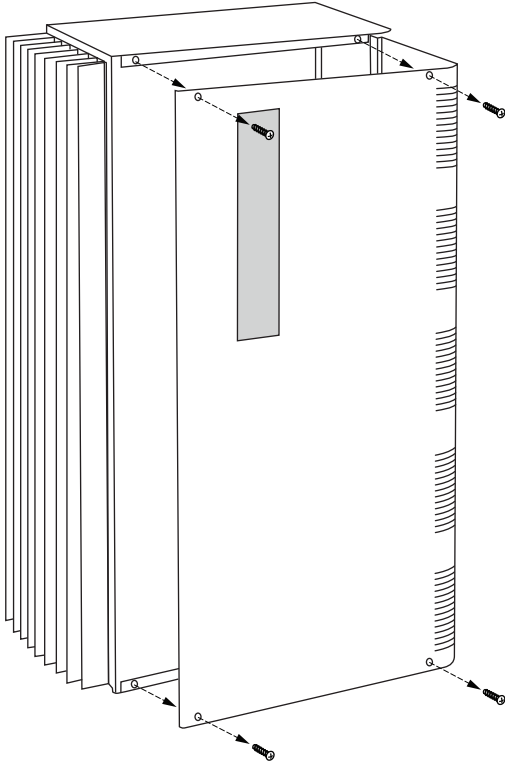

3

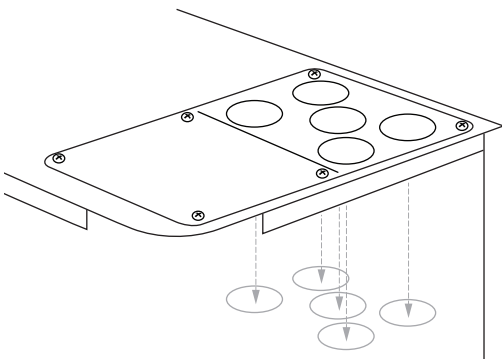

4

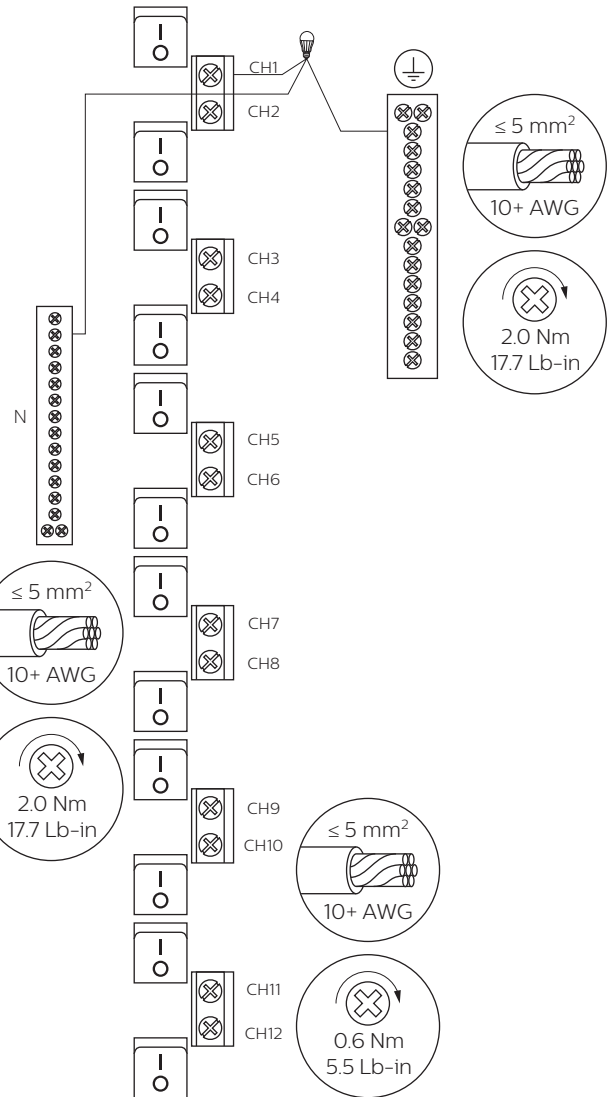
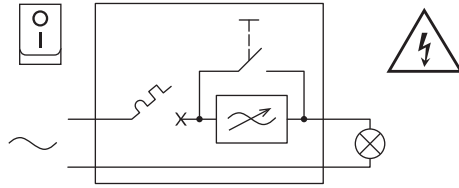
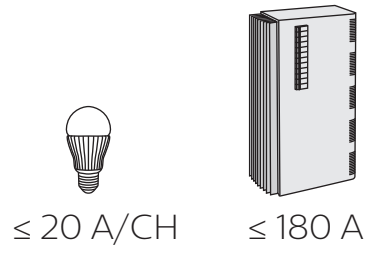

5

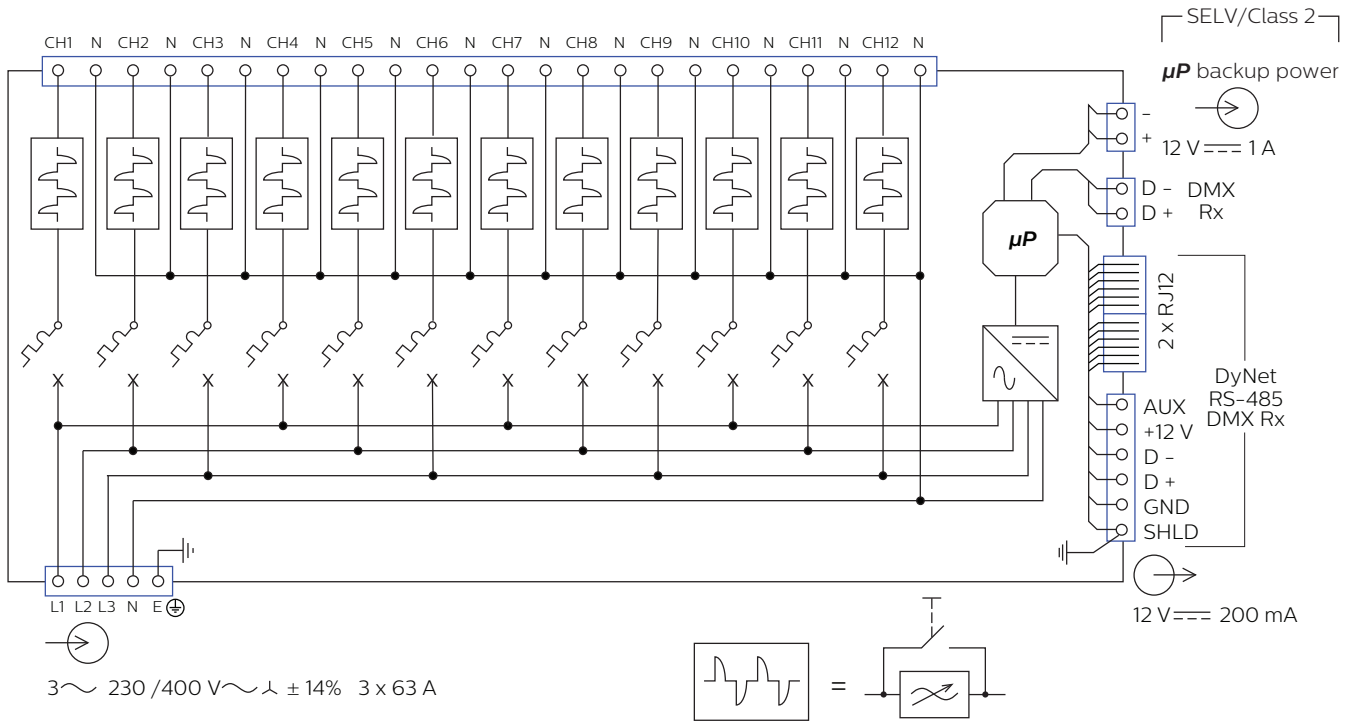

! IEC Overvoltage Category III

6

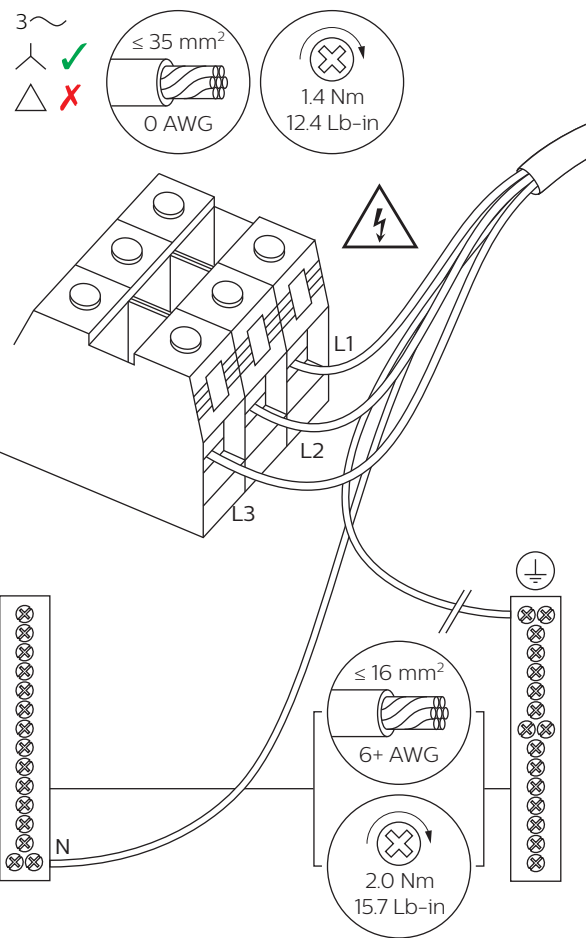

7 A

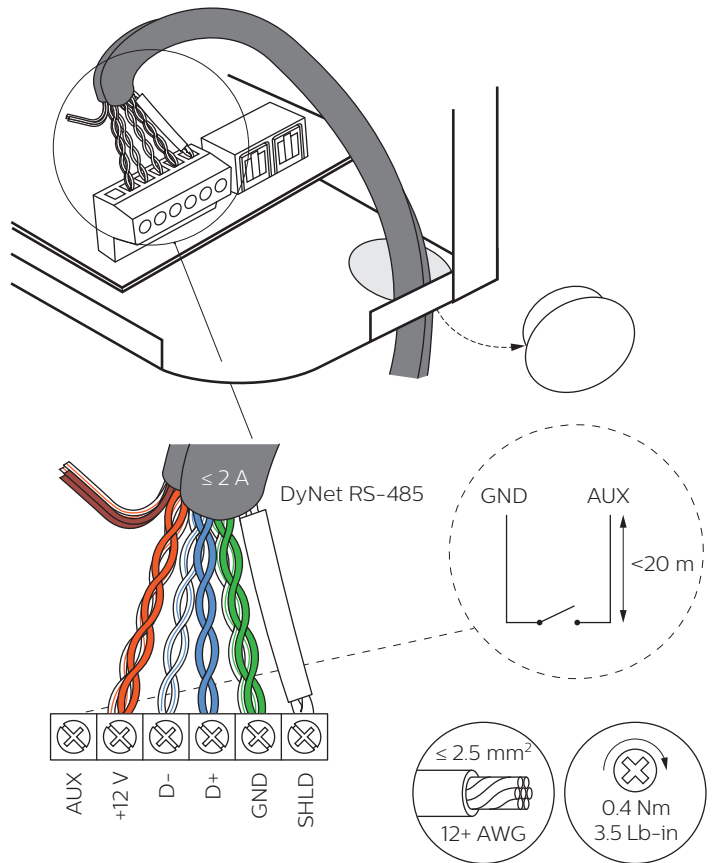

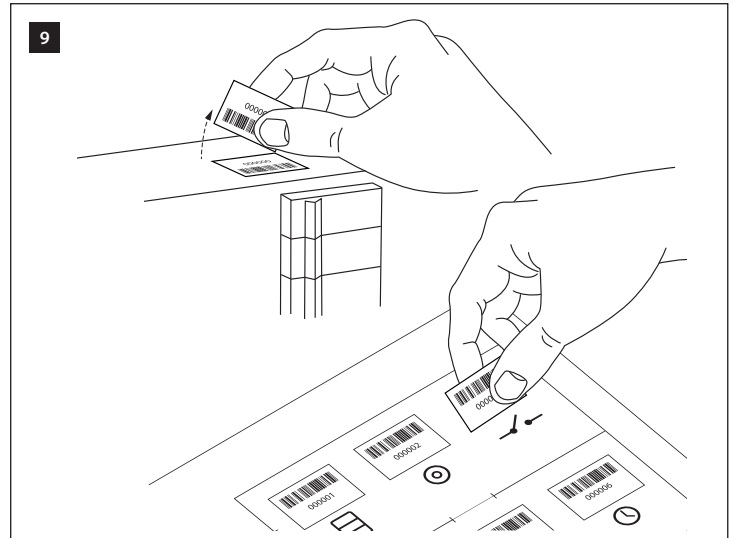
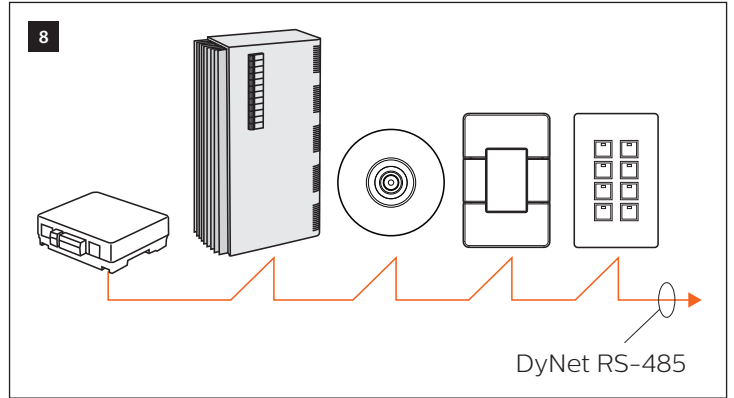
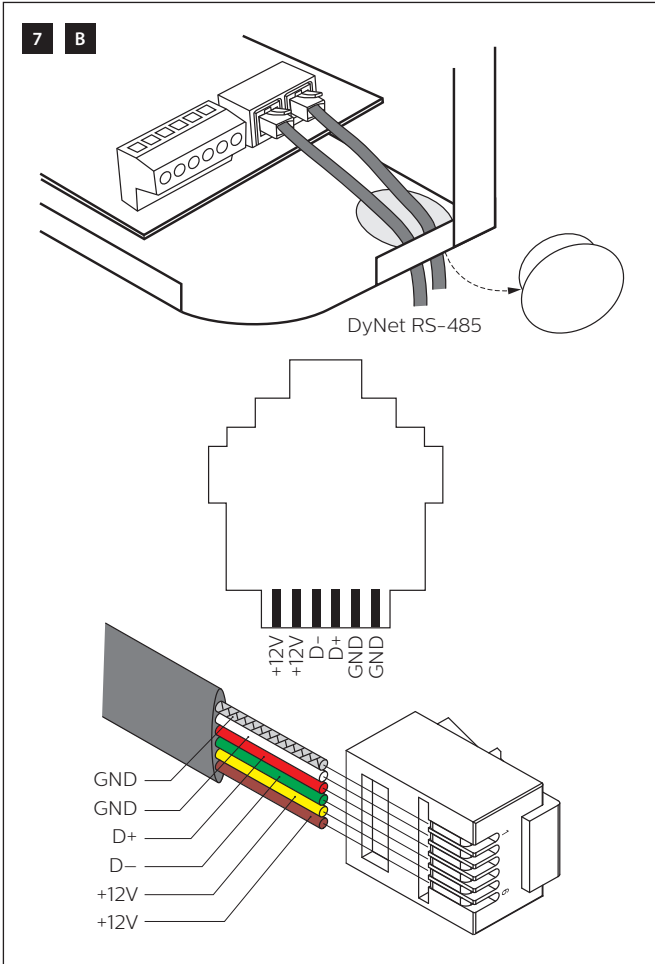

⚠ Apply de-rating for electronic and LED loads.

⚠ The manufacturer is not responsible for dimmable lamp selection. Each lamp/dimmer combination must be tested for compatibility prior to installation.

⚡ Professional dimmers rated > 1000 W are out of scope of EN 61000-3-2.