

PHILIPS

dynalite 

DLE 120-S

1 x 20A Leading Edge Dimmer Installation Manual



contents

Features.....	2	Troubleshooting.....	8
Important Safeguards.....	2	Specification.....	8
Internal View.....	3		
Mounting.....	4		
Supply & Load Cable Connections.....	5		
Connecting Serial Control Cables.....	6		
Hardware Controls & Analogue Inputs.....	7		



WARNING
ISOLATE FROM
 MAINS SUPPLY BEFORE
 REMOVING THIS COVER
 NO USER SERVICEABLE PARTS INSIDE
 SERVICE BY QUALIFIED PERSONNEL ONLY

Warning

- TO REDUCE THE RISK OF FIRE OR ELECTRIC SHOCK, DO NOT EXPOSE THIS DEVICE TO RAIN OR MOISTURE.
- DO NOT ENERGISE UNLESS THE FRONT COVER IS IN PLACE.
- THIS DEVICE MUST BE EARTHED.
- INSTALLATION, PROGRAMMING AND MAINTENANCE MUST BE CARRIED OUT BY QUALIFIED PERSONNEL.

features

- **Simple Supply Requirements**
Single Phase at 20A.
- **One Leading Edge Dimmed Output**
The 20A output is independently regulated, protecting loads from voltage surges and spikes.
- **8 Multifunction Inputs**
Ideal for interfacing to other systems. When activated, the inputs can be used to trigger Tasks in the internal programmable logic controller.
- **Many Control Options**
Control of this device can be from a combination of methods, eg. serial control port, relay contacts, push button wall stations, infra red receivers and timeclocks. Easy high-level interface to other popular AV control systems and Building Management Systems (BMS) is also available.
- **Simple Installation**
Wall-mount enclosure with mounting lugs facilitates installation. Cable knockouts are provided, at the top of the enclosure for supply and load cables, with data cables at the bottom.

important safeguards

Warning – This is a class A product. In a domestic environment this product may cause radio interference, in which case the user may be required to take adequate measures.

Read Instructions – We recommend that you read this Instruction Manual Prior to commencement of installation. Retain instructions and give the end user.

Troubleshooting - If problems are encountered, check the Troubleshooting section on page 10.

Special Programming – This device will only operate in basic modes unless programmed via a computer. If programming is required, contact your local agent for details. Once the data cable is connected to the devices, the factory default settings will allow any control panel to control all channels in all dimmers.

Check Connections – Treat this device as a switchboard that has been shipped. Tighten all load-carrying screw connections, as vibrations from transport can cause MCB and terminal block screws to become loose.

Power Sources – This device should only be operated from the type of supply specified on the front panel. This device *must* be earthed.

Output Circuits – The load on a circuit should not exceed the specified capacity of 20A. Loads should be calculated to ensure that the overall maximum capacity of 20A is not exceeded.

Multifunction Inputs – These inputs are designed for dry contacts or SELV analogue inputs only. Cables to these inputs must be treated as SELV.

Mounting Location – This device must be mounted right way up, on a vertical surface (refer to page 4 for mounting instructions). The specified minimum clearance of 100mm for all sides must be adhered to. Install in a dry, well-ventilated location. Controllers may emit some mechanical noise. Take this into account when deciding the mounting location.

Data Cable – The recommended cable for connections to the serial port is screened, stranded RS485 data cable with three twisted pairs. Part numbers for various manufacturers are listed on page 6. This cable should be segregated from mains cables by a minimum distance of 300mm. If anticipated cable runs are over 600 metres for serial cables, consult your dealer for advice. Do not cut or terminate live data cables.

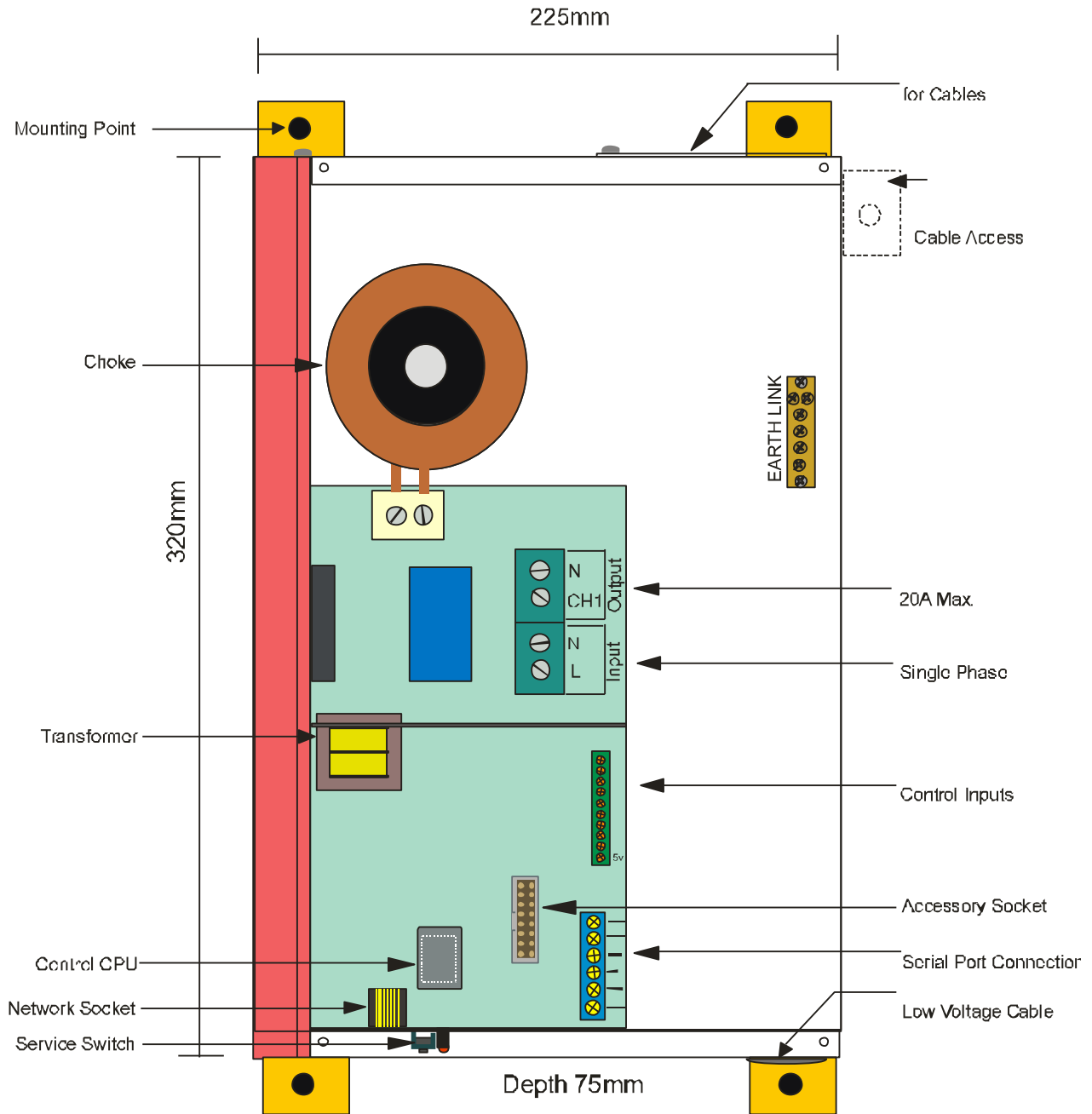

For spare parts, please call your nearest Dynalite Customer Service Centre, and specify **DLE120-S**

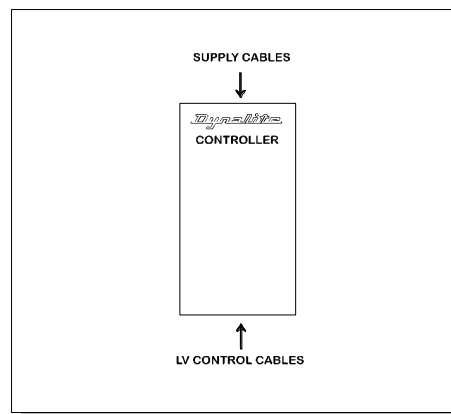
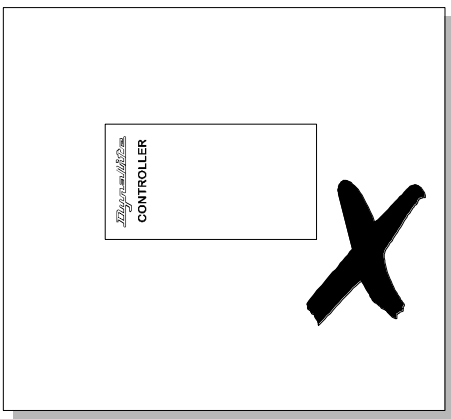
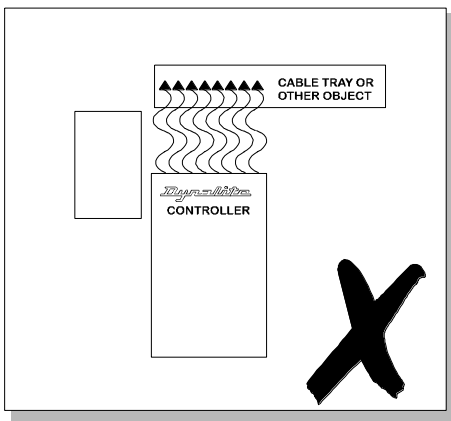
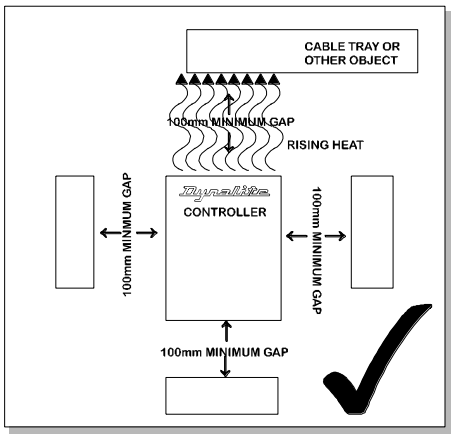

Select a Suitable Location

This device is designed for indoor use only. If installing in an external location, the DLE120-S must be housed in a suitable well-ventilated enclosure. Choose a dry location, that will be accessible after the installation is complete. The DLE120-S should be mounted *vertically, the right way up*. The DLE120-S requires an air gap of 100mm on each side and at the top and bottom of the device. This air gap is required to ensure serviceability of the DLE120-S without complete removal from the mounting surface. This device may emit some mechanical noise. Take this into account when deciding the mounting location.

Fixing the Device

The DLE120-S has four mounting brackets that attach to the rear of the enclosure. The brackets are designed to accommodate 4 fixing screws up to 8mm diameter. The DLE120-S can be fixed to the wall without opening the cabinet or removing covers. Make sure no dust or other debris enters the device during installation. Do not leave the front cover off for any length of time. Excessive dust and dirt can degrade the cooling of internal components.

Allow for Cable Entry

Supply, load and load control cables enter the enclosure at the top. If these cables are fed from below the mounting position, they should be routed around the enclosure to enter at the top. An alternative method is to stand the enclosure off from the mounting surface by mounting it on a cable tray or a Unistrut style product. The cables can then be routed between the enclosure and the mounting surface, and enter the enclosure via the cutout provided on the mounting face. The control cables enter at the bottom of the enclosure. Control cables should never be run in the mains voltage sections of the enclosure.

supply and load cable connections

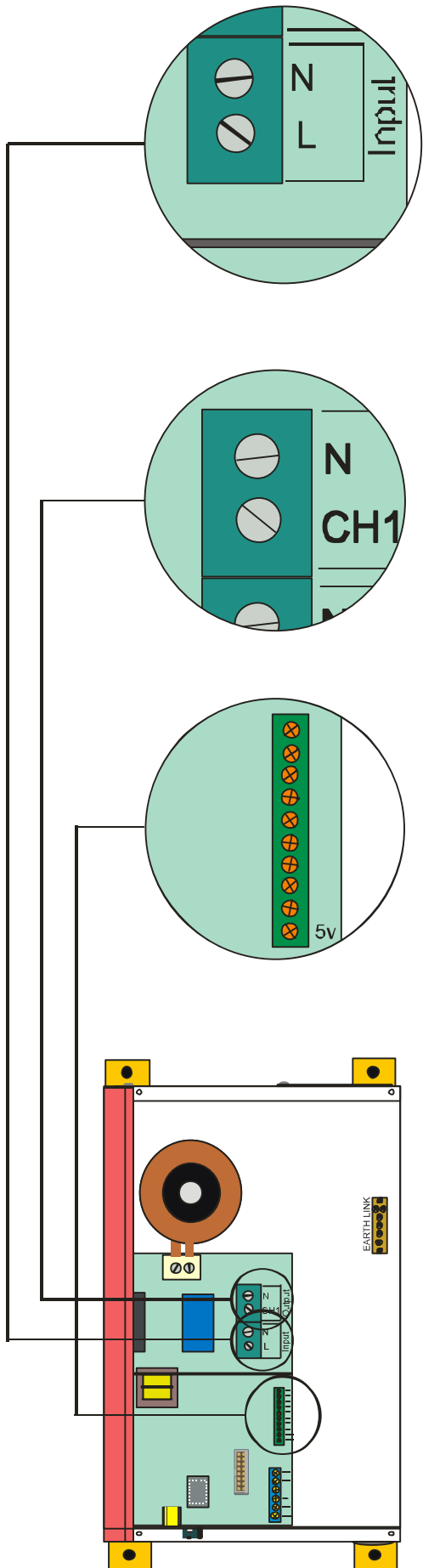

Supply Cables

The supply input terminals are located toward the top left of the enclosure and consists of Neutral, Line, and an Earth link located on the chassis, all of which will accept up to 10mm² cables. The supply cables should have a capacity of at least 20A.

Load Cables

Load cables can be terminated on the 2 way Load terminal strip. These connectors will accept up to 10mm² cables. Calculate the intended load, and ensure that it is below the maximum capacity of an individual channel, which is 20A. Derate for reactive loads.

Control Input Cables

There are 8 control inputs that terminate on a 10 way terminal strip. They are configurable to Dry Contact and 0-10V Analogue. These terminals are SELV (safety extra low voltage) and any cables connected to them should be segregated from mains cables.

Energising the Device

If it is necessary to energise load circuits before any control cables are connected, it is acceptable to replace the cover and energise the device immediately, as the default factory programming is to have all channels set to 100% output. If there is no output on any or all channels, see the Troubleshooting section (page 10). The device should be de-energised before terminating the control and data cables.

connecting serial control cable

Connect Data Cable in a 'Daisy Chain'

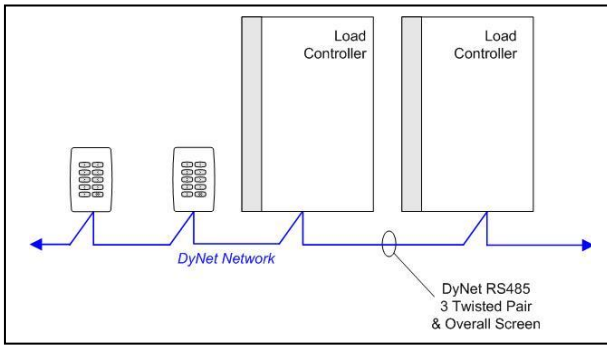

Determine Your Requirements

Serial Ports are used to interconnect other dimmers, smart control panels, sensors and AV controllers. Serial port devices can be identified by 4 terminals, labelled: GND, DATA+, DATA-, +VE.

Serial Cable Connections

There is one RS485 port for DyNet signals, in the form of a RJ12 socket, on the front panel, which is used for the temporary connection of a PC or a Portable Programmer. There are data terminals on the control card, for permanent connections. The recommended cable for connections to the serial port is screened, stranded RS485 data cable with three twisted pairs. Recommended cable types include:

Belden:	9503
Dynalite:	DYNET-STP-CABLE
Garland:	MCP3S
Hartland:	HCK603
M&M Cable:	B2003CS
M&M Cable:	B9503CS
Multicable:	AWM E120236 2092 20
RS Components:	368-687
Dynalite	DYNET-STP-CABLE

One pair is paralleled for GND, one pair paralleled for +VE, and one pair used for DATA+ and DATA-.

Recommended Cable Colour Coding

Green/White pair	paralleled for GND
Orange/White pair	paralleled for +VE
Blue/White pair	Blue for DATA+
	White for DATA-
Brown/White pair	Spare or for Join

The colour-coding scheme used is not critical, as long as the same scheme is used throughout the installation.

RJ12 Socket Connections

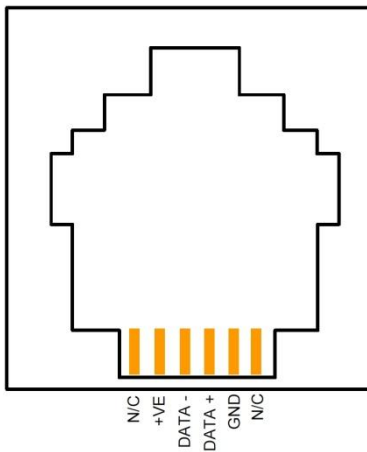

Serial Cable Permanent Connections

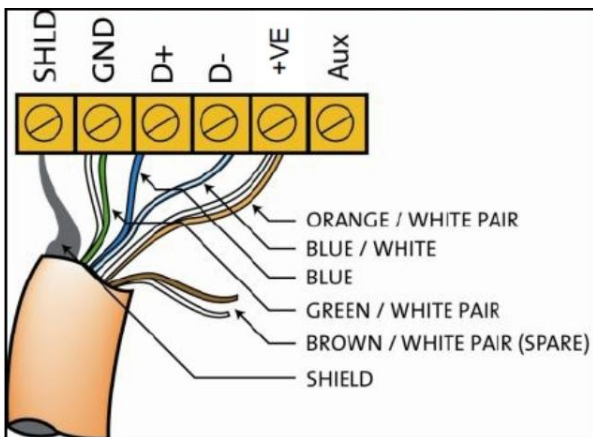

Serial Cable Connecting Method

The recommended connecting method is to 'daisy chain' devices (ie. starting at the first device, then looping in then out of devices, with a single cable terminating at the last device. There should not be any spurs or stubs, and only the first and last device should terminate 1 cable, all other devices should terminate 2 cables). Devices may be wired in any order. The Data Cable should be segregated from any Mains Cables by 30mm. *A data cable that is connected to an energised dimmer is live. Do not cut or terminate live data cables.* If the data cable has to cross over any mains cables, it should do so at a 90° angle.

hardware controls & analogue inputs

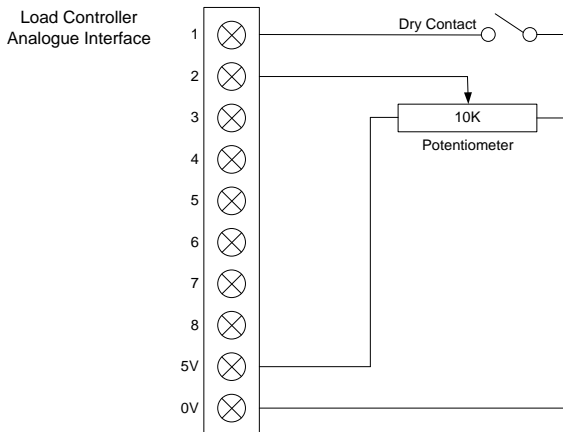

Analogue Inputs - The DLE120-S is supplied with an analogue input interface. This interface has 8 SELV (Safety Extra Low Voltage) inputs, each input is individually configurable to operate in dry contact or analogue mode. When in analogue mode, the input range is configurable to be 0-5V or 0-10V. A buffered 5V terminal is provided for ease of connection to passive faders. 0-10V mode is useful for connection to other vendor's control equipment. These inputs are fed into a programmable logic controller, which has access to the DyNet network and can control other devices in the system, as well as the device on which the port physically resides.

Recommended values for potentiometers is 5K Ohms to 10K Ohms. Ensure that cables connected to the analogue input interface are segregated from mains cables.

AUX Input - This is a dry contact interface that is active low. The dry contact is connected between the AUX and GND terminals on the DyNet connector strip. The function of the AUX input is programmable. Ensure that the cable length between the dry contact and terminal strip is no longer than 2 metres.

Service LED - The Service LED has 3 signalling modes, which are useful for troubleshooting:

Blinking slowly (1Hz) = Normal Operation

Blinking fast (4Hz) = Network Activity

Detected

On = Fault

Service Switch - The Service Switch has three functions:

1 push = Transmit Network ID

3 pushes = All Channels 100%

Push & hold for 4 sec = Reboot

Accessory Module Socket - Accepts plug in modules for optional features such as DMX512 ports and Time clocks. Consult your distributor for details on the available accessory modules.

troubleshooting

Check the following list. If you are still unable to rectify the situation, contact your nearest Dyalite office. A complete list of distributors worldwide can be found on the Internet at:

www.philips.com/dyalite

Please ensure that you have completed the following prior to calling our technical support department.

- Check all symptoms in the Troubleshooting list
- Check for any deviations between the installation and the installation instructions
- Make a list of the model numbers of all devices used in the system

SYMPTOM	PROBABLE CAUSE	ACTION
Load Controller does not operate at all. No Service LED activity. Power supply indicator LED on PCB not lit.	Incorrect connection of Mains supply, or no power available.	Check power supply to Load Controller. Check Line and Neutral input connections.
Power supply indicator LED lit, but no Service LED activity.	Supply voltage too low, short circuit on network. Control PCB faulty.	Check supply voltage is at least 75% of rated voltage. Check 5V & 12V terminal voltages, 5V supply must be present. Disconnect network bus and restore power. Replace control PCB.
Load Controller will not respond to control panel push buttons.	Control panel incorrectly wired or incorrect configuration.	Check operation of LEDs on control panel. Push button on panel and study response of service LED.
Load Controller operates properly but circuit breakers keep tripping.	Instant tripping: - short circuit on load. Delayed tripping: - Load Controller overloaded.	Check load wiring for short circuits. Verify Load Controller loading with current tester (don't forget to de-rate for low power-factor loads and transformer losses). Check that the breaker terminals are tight.
Fluorescent lights won't dim.	Wrong type of ballast or ballast incorrectly wired. Control cable from DRC810DT to ballasts not installed.	Check ballast type. Check actual wiring against ballast manufacturer's diagram. Check 1-10V/DSI cable and settings.

specification

- Supply:** 230V ±14% 50/60Hz Single Phase at 20A
- Outputs:** 1 x dimmed output (leading edge) 20A
- Control Inputs:** 1 x RS485 DyNet serial port
1 x programmable dry contact AUX input
8 x dry contact inputs
- User Controls:** Service Switch
Diagnostic LED
- Internal Controls:** Programmable Logic Controller
Dyalite Accessory Module enabled
- DyNet DC Supply:** 90mA (supply for approx. 4.5 Smart Panels)
- Preset Scenes:** 170
- Supply Terminals:** Line, Neutral – 2 x 4mm² max conductor size
- Output Terminals:** Line, Neutral for each channels 1-8
2 x 4mm² max conductor size
Earth link bar provided
- Cable Entries:** Mains – 1 x 75mm x 53mm removable gland plate
Data – 1 x 25mm dia. knockout
- Diagnostic Functions:** Device Online/Offline status
Circuit run time tracking (optional)
- Compliance:** CE, C-Tick
- Construction:** Alloy/Steel wall mount case with epoxy finish
- Dimensions:** Height 320mm x Width 225mm x Depth 75mm (excludes wall brackets)
- Weight:** 3.5 Kilograms

DLE120-S Installation Manual Rev G.doc Specifications and design subject to change without notice.
 Dyalite Manufactured by WMGD Pty Ltd (ABN 33 097 246 921). All rights reserved. Dyalite, Dimtek, DyNet and DLight and associated logos are the registered trademarks of Dyalite Intelligent Light Pty Ltd. Not to be reproduced without permission.
 Unit 6, 691 Gardeners Road Mascot NSW 2020 Australia Tel: +61 2 8338 9899 Fax: +61 2 8338 9333
 E-mail: dyalite.info@philips.com Web: Philips.com/dyalite