

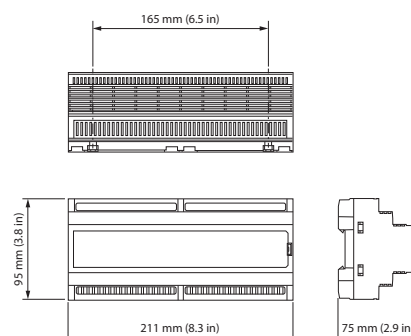

DDMC-GRMSPLUS Hotel Room Controller

Compact dedicated controller for hotel room control solutions

The DDMC-GRMSPLUS is designed specifically for use in hotel rooms and suites. Featuring a range of outputs suitable for control of services found in hospitality environments, the compact unit delivers the ultimate in guest comfort through seamless control of lighting, curtains and blinds, as well as limiting standby current consumption from electronic devices connected to GPOs.



- 16 A power relay — Stops standby power consumption from electronic devices still connected to general purpose outlets once guests have left.
- Five trailing edge dimming channels — For use with LED lighting as commonly found in hotel room applications.
- Three switching channels — Provide additional on/off control of other lighting fixture types.
- Two motor directional relays — For use with motorized blinds and curtains.
- Sixteen DMX512 output channels — In situations where color changing lighting is required as part of overall room ambience.
- Built-in dialswitches — Allow the device's network address to be configured without commissioning software, providing faster installation.
- Supports two DyNet ports — The device can be used as a standalone solution, or integrated with other Philips Dynalite network devices, as part of a larger scale system.

For detailed product information, please refer to the product information pages at www.philips.com/dynalite and follow the links.

Supplied by:

lightmoves

Melbourne
03 9701 2500

Sydney
02 9737 8988

info@lightmoves.com.au www.lightmoves.com.au

PHILIPS

dynalite 

Specifications

Due to continuous improvements and innovations, specifications may change without notice.

Item	Specification	Details
Electrical	Input Voltage	Device feed 230V ±14% 50 / 60 Hz Single Phase @ max 0.25 A (must be on the same phase as feeds for Ch 2-4 & 5-7). Ch 1 feed 16A Ch 2 - 4 group feed 6A Ch 5 - 7 group feed 6A Ch 8 - 9 group feed 6A M1 & M2 group feed 6A <small>A derating factor may be needed if installed in a smaller sealed switchboard</small>
	DyNet DC Supply	DyNet 1 Port: 12VDC @ 200mA DyNet 2 Port: 12VDC @ 50mA
	Outputs	Ch 1 Switching, feed from any phase, 240 VAC 16 A resistive, 165 / 800A inrush rated Ch 2-4 & 5-7 Ch 2-6: 2A Trailing Edge Dimmer Regulating device - Dual MOSFETs, 21 A, 500 V, 84 A surge Dimmer Channel Power Conditioning: <ul style="list-style-type: none"> • Over voltage protection • Surge protection • Brownout/Sag protection • Spike protection • Soft start • 16 bit fade resolution (65,536 steps) Ch 7: 6 A max switching 240 VAC 8 A rated TV-8 type relays, 100 A inrush rating 30,000 switching cycles M1 & M2 Switching and motor direction control. Feed 6 A max from any phase or ELV supply. Cascaded single SPST 8 A TV-8 and SPDT 8 A TV-5 / TV-3 relays, 240 VAC, 100 inrush rating, 30,000 switching cycles DMX512 Transmit Single DMX512 port, max 16 channels
Control	Control Inputs/Outputs	1 DyNet 1 RS-485 Serial Port 1 DyNet 2 RS-485 Serial Port
	User Controls	Service switch Diagnostic LED DyNet addressing dipswitches
	Preset Scenes	170
	Internal Controls	Inbuilt Programmable Logic Controller
Physical	Supply Terminals	Line, Neutral, Earth 2 x 2.5mm ² or 1 x 4 mm ² conductor size
	Output Terminals	1 Common Feed In per group, single or multiple Ch Out, up to 1 x 2.5mm ² or 2 x 1.5 mm ² conductor size
	DyNet Termination	DyNet 1 Port: 1 RJ12 modular jack DyNet 2 Port: 2 RJ12 modular jacks
	DMX Termination	3 pole pluggable screw clamp terminal, 2 x 1.5 mm ² max conductor size
	Dimensions (H x W x D)	95 mm x 211 mm x 75 mm (3.8" x 8.3" x 2.9")
	Packed Weight	0.82 kg
	Construction	Polycarbonate DIN-rail enclosure (12 unit)
	Operating Conditions	Temperature: -0 to 40° C ambient Humidity: 0 to 95% non-condensing
	Storage & Transport	Temperature: -25 to 70° C ambient Humidity: 0 to 90% non-condensing
Certification	Certification	CE, C-Tick
Options & Ordering	Standard Product	DDMC-GRMSPLUS (Philips 12NC - 913703051809)

Electrical Diagram

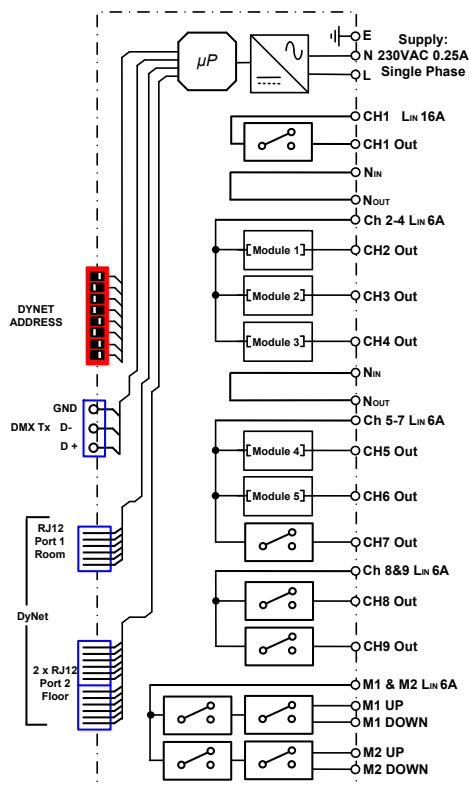

Philips Dynalite
6 / 691 Gardeners Road
Mascot, NSW 2020
Australia
Tel: +61 2 8338 9899
Email: dynalite.info@philips.com
Web: www.philips.com/dynalite



Specifications subject to change without notice. ©WMGD Pty Ltd Trading as Dynalite. Unit 6, 691 Gardeners Road Mascot 2020 Australia. ABN 33 097 246 921. All rights reserved. Dynalite, DyNet and associated logos are the registered trademarks of WMGD Pty Ltd. Not to be reproduced without permission.