



DDBC300-DALI DALI Driver Controller

Cost-effective DALI control solution

The DDBC300-DALI delivers cost-effective control of DALI high frequency fluorescent drivers through provision of three full universes totalling 192 DALI addresses.

- Compatible with a range of DALI fittings and devices — Including; DALI HF fluorescent drivers, DALI electronic low voltage transformer and DALI LED fixtures.
- Fully scalable network solution — Direct mapping from DALI to the Philips Dynalite DyNet network protocol eliminates DALI imposed limits, such as maximum group sizes.
- Flexible mounting solution — A DIN-rail mountable device, designed to be installed into the distribution board supplying power to the controlled lighting circuit.
- Integral DALI bus power supply — Removes the need for provision of a separate external power supply and reduces distribution board wiring complexity.
- Inbuilt diagnostic functionality — Features lamp and driver failure reporting, driver run time tracking for each driver and Device Online/Offline status indication.

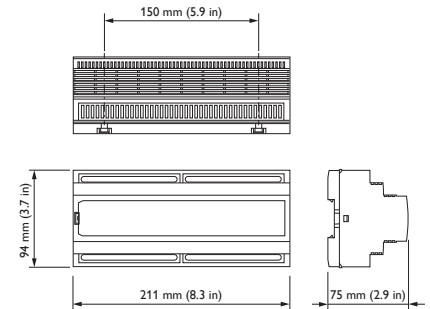

For detailed product information, please refer to the product information pages at www.philips.com/dynalite and follow the links.

Specifications

Due to continuous improvements and innovations, specifications may change without notice.

Item	Specification	Details
Electrical	Input Voltage	100 - 240 VAC 50 / 60 Hz Single Phase @ 0.5 A
	DyNet DC Supply	12 VDC @ 200 mA (supply for approx 10 user interfaces)
	Outputs	3 x DALI control outputs, each supporting one full DALI universe of 64 addresses (192 total), including backward channel
	Bus Power Supply	Inbuilt DALI bus power supply 15 V rated 128 mA per universe
Control	Control Inputs/Outputs	One DMX512 / RS-485 DyNet serial port One programmable dry contact AUX input
	User Controls	Service override switch Diagnostic LED
	Preset Scenes	64
	Diagnostic Functions*	Lamp failure reporting Driver failure reporting Driver run time tracking for each driver and the switched output Device online/offline status * EnvisionManager interface required for analyzing diagnostic data. The availability of some diagnostics is dependent on driver type.
Physical	Supply Terminals	Line, Neutral, Earth 1 x 4 mm ² maximum conductor size
	Output Terminals	3 x DALI driver circuits: DA -, DA + 1 x 4 mm ² maximum conductor size
	Dimensions (H x W x D)	94 mm x 211 mm x 75 mm (3.7" x 8.3" x 2.9")
	Packed Weight	0.49 kg
	Construction	Polycarbonate DIN-rail enclosure (12 unit)
	Operating Conditions	Temperature: 0 to 40° C ambient Humidity: 0 to 95% non-condensing
	Storage & Transport	Temperature: -25 to 60° C ambient Humidity: 0 to 90% non-condensing
Certification	Certification	CE, RCM, IEC62386
Options & Ordering	Standard Product	DDBC300-DALI (Philips 12NC - 913703031109)



Electrical Diagram

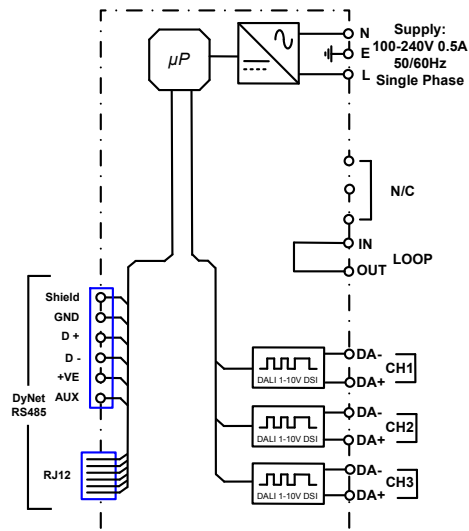

Philips Dyalite
6 / 691 Gardeners Road
Mascot, NSW 2020
Australia
Tel: +61 2 8338 9899
Email: dyalite.info@philips.com
Web: www.philips.com/dyalite

Specifications subject to change without notice. ©WMGD Pty Ltd Trading as Dyalite. Unit 6, 691 Gardeners Road Mascot 2020 Australia. ABN 33 097 246 921. All rights reserved. Dyalite, DyNet and associated logos are the registered trademarks of WMGD Pty Ltd. Not to be reproduced without permission.