



Date: _____ Type: _____

Firm Name: _____

Project: _____

iW Reach Powercore gen2

23° spread lens, CQC

Premium long-throw exterior LED floodlight with intelligent white light

iW Reach Powercore gen2, the intelligent white light version of our flagship, high-performance exterior architectural floodlight, outputs washes of white light in color temperatures ranging from a warm 2700 K to a cool 6500 K. iW Reach Powercore gen2 combines all the benefits of LED-based lighting in an elegant fixture specifically designed for skyscrapers, casinos, large retail exteriors, bridges, piers, public monuments, and themed attractions. With significantly more lumen output than any other competitive fixture and unprecedented light projection, this powerful fixture represents the next generation in exterior illumination.

- Unique split design — Spread lenses fit over each fixture half to support diffuser combinations. Use one spread lens on the lower half to bathe a large façade with light at street level, and a different lens to project light hundreds of feet up the building's walls.
- Integrates Powercore technology — Powercore technology rapidly, efficiently, and accurately controls power output to fixtures directly from line voltage. The Philips Color Kinetics Data Enabler Pro merges line voltage with control data and delivers them over a single standard wire, dramatically simplifying installation and lowering total system cost.
- High-performance illumination in a wide range of color temperatures — Channels of warm, neutral, and cool white LEDs produce temperatures ranging from 2700 K to 6500 K, offering the greatest possible light intensity at all temperatures. Fixture brightness can be varied while maintaining constant temperature.
- Versatile optics — Exchangeable spread lenses of 8°, 13°, 23°, 40°, 63°, and an asymmetric 5° x 17° support a multitude of applications, including spotlighting, wall grazing, and asymmetric wall washing.
- Simple fixture positioning — Rugged, slim-profile mounting bracket allows simple

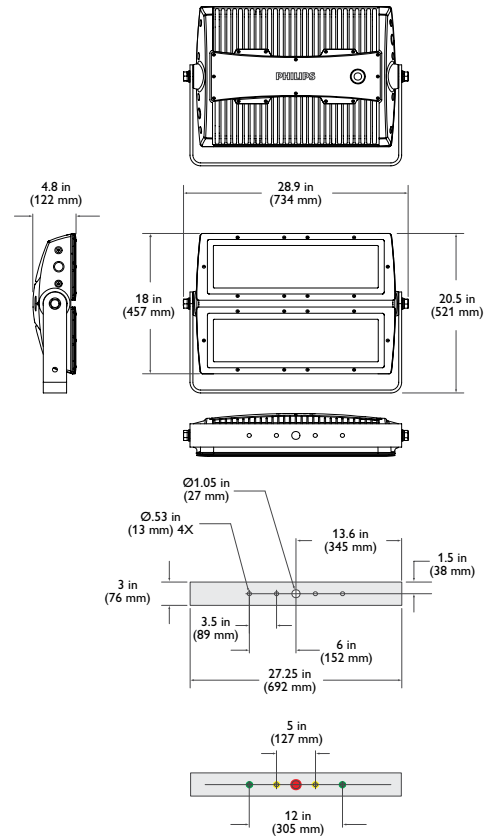

positioning and fixture rotation through a full 360°. Side locking bolts reliably secure fixture with standard wrench.

- Universal power input range — Accepts a universal power input range of 100 – 240 VAC, allowing long fixture runs and consistent installation in any location around the world. Each Data Enabler Pro can support multiple fixtures for illuminating even the largest exterior façades and structures.

For detailed product information, please refer to the iW Reach Powercore gen2 Product Guide at www.philipscolorkinetics.com/ls/intelliwhite/iwreach/

PHILIPS

Photometrics

Photometric data is based on test results from an independent NIST traceable testing lab. IES data is available at www.philipscolorkinetics.com/support/ies.

23° spread lens, half unit

Lumens	Efficacy
6104	49.9 lm / W

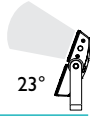

Polar Candela Distribution

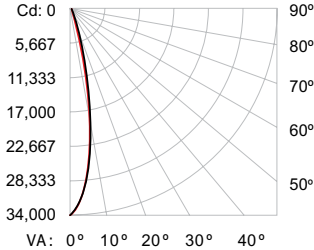

	0	25	45	70	90
0	33622	33622	33622	33622	33622
5	28924	28790	28926	28882	28802
15	9639	9594	9569	9500	9423
25	1339	1311	1289	1225	1196
35	215	210	201	194	193
45	109	107	103	102	104
55	74	71	68	68	68
65	54	52	50	49	49
75	40	39	38	36	35
85	30	30	29	29	29
90	29	29	29	29	29

Illuminance at Distance

5 fc	3.1 ft	3.1 ft
4 fc	4.7 ft	4.6 ft
1 fc	6.3 ft	6.2 ft
4 fc	7.8 ft	7.7 ft
8 fc	9.4 ft	9.3 ft

Coefficients Of Utilization - Zonal Cavity Method

Effective Floor Cavity Reflectance: 20%

RCC %:	80	70	50	30	10	0		
RW %:	70	50	30	0	50	30	20	0
RCR:	0	119	119	119	119	116	116	100
1	115	112	110	109	112	110	109	96
2	111	107	104	101	109	105	103	93
3	107	103	99	96	106	101	98	90
4	104	99	95	92	103	98	94	86
5	101	95	91	88	100	94	91	85
6	98	92	88	85	97	91	88	83
7	96	89	85	82	95	89	85	81
8	93	87	83	80	92	86	83	79
9	91	85	81	78	90	84	80	77
10	89	82	79	76	88	82	78	75

Zonal Lumen

Zone	Lumens	% Fixture
0 - 60	5981.3	98.0 %
60 - 90	123.0	2.0 %
0 - 90	6104.3	100.0 %

5° native (no spread lens), half unit

Lumens	Efficacy
6710	56.7 lm / W



Polar Candela Distribution

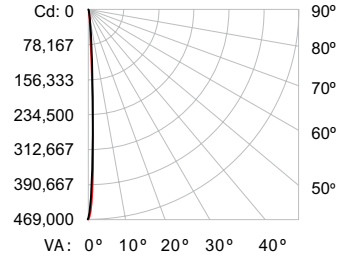

	0	25	45	70	90
0	468056	468056	468056	468056	468056
5	80134	80205	77031	66862	62241
15	802	793	805	811	840
25	237	235	251	257	284
35	131	126	132	125	174
45	81	76	77	78	80
55	62	79	59	64	61
65	56	50	49	52	48
75	45	38	38	38	36
85	34	33	33	33	34
90	33	33	33	33	33

Illuminance at Distance

Center Beam fc	Beam Width
4 ft	29,254 fc 0.4 ft 0.4 ft
8 ft	7,313. fc 0.9 ft 0.8 ft
12 ft	3,250 fc 1.3 ft 1.2 ft
16 ft	1,828 fc 1.7 ft 1.6 ft
20 ft	1,170 fc 2.2 ft 2.0 ft
24 ft	813 fc 2.6 ft 2.4 ft

685 ft (208.8 m) Vert. Spread: 6.2°
1 fc maximum distance Horiz. Spread: 5.7°

Coefficients Of Utilization - Zonal Cavity Method

Effective Floor Cavity Reflectance: 20%

RCC %:	80	70	50	30	10	0		
RW %:	70	50	30	0	50	30	20	0
RCR:	0	119	119	119	116	116	100	
1	116	114	112	110	113	111	110	
2	113	109	107	105	111	108	105	
3	110	106	103	101	108	105	102	
4	108	103	100	98	106	102	99	
5	106	101	98	95	104	100	97	
6	104	99	96	93	103	98	95	
7	102	97	94	92	101	97	94	
8	101	96	93	91	100	95	93	
9	99	95	92	90	99	94	91	
10	98	93	91	89	98	93	90	

Zonal Lumen

Zone	Lumens	% Fixture
0 - 60	6580.4	98.1 %
60 - 90	130.0	1.9 %
0 - 90	6710.4	100.0 %

Specifications

Due to continuous improvements and innovations, specifications may change without notice.

Item	Specification	Details
	Color Temperature*	2700 K – 6500 K
	Lumens†	6104 (half unit)
	Efficacy (lm / W)	49.9 (half unit)
	CRI	79 (no spread lens, full unit)
Electrical	Input Voltage	100 – 240 VAC, auto-switching, 50 / 60 Hz
	Power Consumption	250 W maximum at full output, steady state
	Power Factor	.99 (no spread lens, full unit, all channels full on) @ 120 VAC
Control	Interface	Data Enabler Pro (DMX / Ethernet)
	Control System	Philips Color Kinetics full range of controllers, including Light System Manager, iPlayer 3, and ColorDial Pro, or third-party controllers
Physical	Dimensions (Height x Width x Depth)	20.5 x 28.9 x 4.8 in (521 x 734 x 122 mm)
	Weight	75 lb (34 kg)
	Effective Projected Area (EPA)	0.42 m ²
	Housing	Die-cast aluminium, powder-coated finish
	Lens	Tempered glass
	Fixture Connections	Integral male / female waterproof connector, 6 ft (1.8 m) unified power / data cable
	Temperature Ranges	-40° – 122° F (-40° – 50° C) Operating -4° – 122° F (-20° – 50° C) Startup -40° – 176° F (-40° – 80° C) Storage
	Humidity	0 – 95%, non-condensing
Certification and Safety	Certification	CQC, CE, FCC Class A, PSE
	Environment	Dry / Damp / Wet Location, IP66

* Color temperatures conform to nominal CCTs as defined in ANSI Chromaticity Standard C78.

† Lumen measurement complies with IES LM-79-08 testing procedures.



CHROMACORE[®] | OPTIBIN[®] | POWERCORE[®]
CK TECHNOLOGY | CK TECHNOLOGY | CK TECHNOLOGY

Lumen Maintenance

Threshold*	Ambient Temperature	Reported†	Calculated†
L90	@ 25°C	42,000 hrs	42,000 hrs
	@ 50°C	42,000 hrs	42,000 hrs
L80	@ 25°C	42,000 hrs	>100,000 hrs
	@ 50°C	42,000 hrs	>100,000 hrs
L70	@ 25°C	42,000 hrs	>100,000 hrs
	@ 50°C	42,000 hrs	>100,000 hrs

* L_{xx} = xx% lumen maintenance (when light output drops below xx% of initial output). All values are given at B50, or the median value where 50% of the LED population is better than the reported or calculated lumen maintenance measurement.

† Lumen maintenance figures are based on lifetime prediction graphs supplied by LED source manufacturers. Whenever possible, figures use measurements that comply with IES LM-80-08 testing procedures.

In accordance with TM-21-11, Reported values represent the interpolated value based on six times the LM-80-80 total test duration (in hours). Calculated values represent time durations that exceed six times the total test duration.

Fixtures and Accessories

Item	Type	Item Number	Philips 12NC
iW Reach Powercore gen2 <i>Includes 6 ft (1.8 m) leader cable</i>	CQC	523-000045-51	912400130285
Replacement Leader Cable 6 ft (1.8 m)	CQC / CE / PSE	108-000043-03	910503700454
Spread Lens with bezel	13°	120-000068-00	910503700506
	23°	120-000068-01	910503700507
	40°	120-000068-02	910503700508
	63°	120-000068-03	910503700509
	Asymmetric (5° x 17°)	120-000068-04	910503700510
	8°	120-000068-05	910503700511
Data Enabler Pro	3/4 in / 1/2 in NPT (U.S. trade size conduit)	106-000004-00	910503701210
	PG21 / PG13 (metric size conduit)	106-000004-01	910503701211

Use Item Number when ordering in North America.



Philips Color Kinetics
 3 Burlington Woods Drive
 Burlington, Massachusetts 01803 USA
 Tel 888.385.5742
 Tel 617.423.9999
 Fax 617.423.9998
www.philipscolorkinetics.com

Copyright © 2009 – 2014 Philips Solid-State Lighting Solutions, Inc. All rights reserved.
 Chromacore, Chromasic, CK, the CK logo, Color Kinetics, the Color Kinetics logo, ColorBlast,
 ColorBlaze, ColorBurst, eW Fuse, ColorGraze, ColorPlay, ColorReach, iW Reach, eW Reach,
 DiMand, EssentialWhite, eW, iColor, iColor Cove, IntelliWhite, iW, iPlayer, Optibin, and Powercore
 are either registered trademarks or trademarks of Philips Solid-State Lighting Solutions, Inc. in
 the United States and / or other countries. All other brand or product names are trademarks
 or registered trademarks of their respective owners. Due to continuous improvements and
 innovations, specifications may change without notice. DAS-000030-04 R06 8-14