



Date: _____ Type: _____

Firm Name: _____

Project: _____

iW Blast Powercore

10° clear lens

The world's leading exterior LED wash fixture with intelligent white light

Higher Output

Three-Channel:

2700 K

4000 K

6500 K

iW Blast Powercore is an intelligent, high-performance white-light LED fixture that goes where white lights have never gone before. With improved output of up to 1852 lumens and superior fixture-to-fixture color consistency, iW Blast Powercore is ideal for situations in which lamp maintenance may be difficult or impossible.

- Integrates patented Powercore technology — Powercore technology rapidly, efficiently, and accurately controls power output to fixtures directly from line voltage. The Philips Color Kinetics Data Enabler Pro merges line voltage with control data and delivers them to the fixture over a single standard wire, dramatically simplifying installation and lowering total system cost.
- Supports new applications for white light— Long useful source life (up to 70,000 hours at 70% lumen maintenance) significantly reduces or eliminates maintenance problems, allowing the use of white lighting in spaces where lamp maintenance may be difficult or impossible.
- High-performance illumination in a wide range of color temperatures — Channels of warm, neutral, and cool white LEDs produce color temperatures ranging from 2700 K to 6500 K. iW Blast Powercore offers the greatest possible light intensity at all color temperatures. Fixture brightness can be varied while maintaining constant color temperature.
- High-intensity, energy-efficient white light — Produces high-intensity illumination at a significantly lower power draw than comparable ceramic metal halide light sources.
- Versatile lighting options — iW Blast Powercore is available in four beam angles: 21° and 36° for soft edges, 83° with no optic for uniformly washing façades, and 10° for extended light projection. Rugged die-cast aluminum housing is available in white or black.
- Flexible light positioning — Locking canopy base offers friction-free rotation of up to 350°, and 110° fixture tilting lets you quickly aim the fixture without special tools.

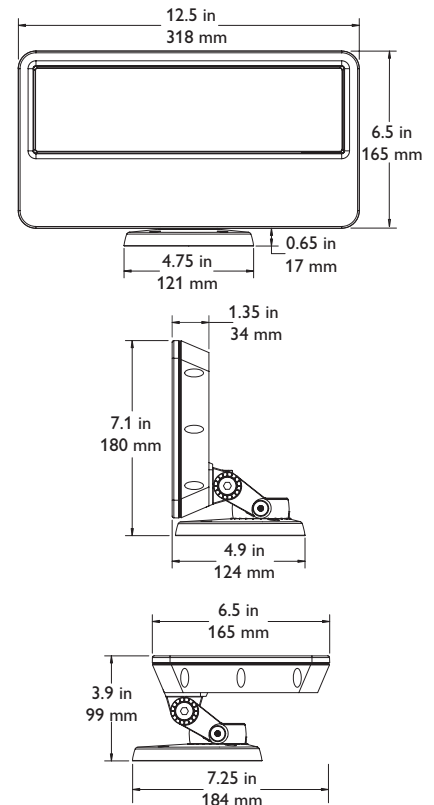

- Easy installation — Fixtures can be mounted to a junction box on a wall, ceiling, or floor for maximum flexibility. The canopy base allows for after-installation rotation without precise junction box positioning.
- Universal power input range — Accepts a universal power input range of 100 – 240 VAC, allowing long fixture runs and consistent installation in any location around the world.
- Outdoor rated — Fully sealed for maximum fixture life, fixtures meet or exceed specifications for use in wet locations.

For detailed product information, please refer to the iW Blast Powercore Product Guide at www.philipscolorkinetics.com/ls/intelliwhite/iwblastpc/

PHILIPS

Specifications

Due to continuous improvements and innovations, specifications may change without notice.

Item	Specification	Details
	Color Temperature*	2700 K – 6500 K
	Lumens†	1852
	Efficacy (lm / W)	36.7
	CRI	81
	Lumen Maintenance‡	70,000 hours L70 @ 25° C 37,000 hours L70 @ 50° C 90,000 hours L50 @ 25° C 68,000 hours L50 @ 50° C
	Mixing Distance	6 in (152 mm) to uniform light
	LED Channels	2700 K / 4000 K / 6500 K
Electrical	Input Voltage	100 – 240 VAC, auto-switching, 50 / 60 Hz via Data Enabler Pro
	Power Consumption	50 W maximum at full output, steady state
	Power Factor	.99 @ 120 VAC
Control	Interface	Data Enabler Pro (DMX / Ethernet) Fixture firmware addressable 8- or 16-bit control
	Control System	Philips full range of controllers, including Light System Manager, iPlayer 3, and ColorDial Pro, or third-party controllers
Physical	Dimensions (Height x Width x Depth)	7.1 x 12.5 x 4.9 in (172 x 317 x 125 mm)
	Weight	6.4 lbs (2.9 kg)
	Effective Projected Area (EPA)	0.05211 m ²
	Housing	Die-cast aluminium, black or white powder-coated finish
	Lens	Clear tempered glass
	Fixture Connections	6 ft (1.8 m) unified power / data cable
	Temperature Ranges	-40° – 122° F (-40° – 50° C) Operating -4° – 122° F (-20° – 50° C) Startup -40° – 176° F (-40° – 80° C) Storage
Certification and Safety	Certification	UL / cUL, FCC, Class A, CE, PSE
	Environment	Dry / Damp / Wet Location, IP66

* Color temperatures conform to nominal CCTs as defined in ANSI Chromaticity Standard C78.



† Lumen measurement complies with IES LM-79-08 testing procedures.

‡ L70 = 70% lumen maintenance (when light output drops below 70% of initial output). L50 = 50% lumen maintenance (when light output drops below 50% of initial output). Ambient luminaire temperatures specified. Lumen maintenance calculations are based on lifetime prediction graphs supplied by LED source manufacturers. Calculations for white-light LED fixtures are based on measurements that comply with IES LM-80-08 testing procedures. Refer to www.philipscolorkinetics.com/support/appnotes/ for more information.

Data Enabler Pro

Item	Type	Item Number	Philips 12NC
Data Enabler Pro	3/4 in / 1/2 in NPT (U.S. trade size conduit)	106-000004-00	910503701210
	PG21 / PG13 (metric size conduit)	106-000004-01	910503701211



Philips Color Kinetics
3 Burlington Woods Drive
Burlington, Massachusetts 01803 USA
Tel 888.385.5742
Tel 617.423.9999
Fax 617.423.9998
www.philipscolorkinetics.com

Photometrics

10° clear lens

Polar Candela Distribution

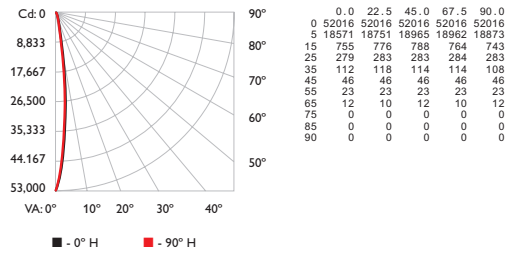

Illuminance at Distance

Center Beam fc	Beam Width
4 ft	3251 fc 0.6 ft 0.6 ft
8 ft	813 fc 1.1 ft 1.1 ft
12 ft	361 fc 1.7 ft 1.7 ft
16 ft	203 fc 2.2 ft 2.3 ft
20 ft	130 fc 2.8 ft 2.9 ft
24 ft	90 fc 3.4 ft 3.4 ft

228 ft (69.5 m) 1 fc maximum distance
■ Vert. Spread: 8.0°
■ Horiz. Spread: 8.2°

Lumens	1852
Efficacy	36.7

For lux multiply fc by 10.7

Refer to the *iW Blast Powercore Product Guide* for information on available accessories, including top hats, half top hats, egg crate louvers, barndoors, and spread lenses.

CHROMACORE[®] | OPTIBIN[®] | POWERCORE[®]
 CK TECHNOLOGY | CK TECHNOLOGY | CK TECHNOLOGY

Fixtures

Item	Type	Housing	Item Number	Philips 12NC
iW Blast Powercore UL / cUL CE	10°	White	523-000071-00	910503702333
		Black	523-000071-01	910503702356
	21°	White	523-000071-02	910503702357
		Black	523-000071-03	910503702358
	36°	White	523-000071-04	910503702359
		Black	523-000071-05	910503702360
83°	White	523-000071-06	910503702361	
	Black	523-000071-07	910503702362	
iW Blast Powercore CQC	10°	White	523-000071-08	910503702438
		Black	523-000071-09	910503702439
	21°	White	523-000071-10	910503702440
		Black	523-000071-11	910503702441
	36°	White	523-000071-12	910503702831
		Black	523-000071-13	910503702832
	83°	White	523-000071-14	910503702833
		Black	523-000071-15	910503702834

Use Item Number when ordering in North America.

Copyright © 2009 – 2012 Philips Solid-State Lighting Solutions, Inc. All rights reserved. Chromacore, Chromatic, CK, the CK logo, Color Kinetics, the Color Kinetics logo, ColorBlast, ColorBlaze, ColorBurst, eW Fuse, ColorGraze, ColorPlay, ColorReach, iW Reach, eW Reach, DIMand, EssentialWhite, eW, iColor, iColor Cove, IntelliWhite, iW, iPlayer, Optibin, and Powercore are either registered trademarks or trademarks of Philips Solid-State Lighting Solutions, Inc. in the United States and / or other countries. All other brand or product names are trademarks or registered trademarks of their respective owners. Due to continuous improvements and innovations, specifications may change without notice. DAS-000023-01 R06 07-12