

# iColor Flex LMX gen2

Flexible strands of large high-intensity LED nodes with intelligent color light



# iColor Flex LMX gen2

## Flexible strands of large high-intensity LED nodes with intelligent color light

iColor Flex LMX gen2 are flexible strands of large, high-intensity, full-color LED nodes designed for extraordinary effects and expansive installations without the constraints of fixture size, shape, or space. Each iColor Flex LMX gen2 strand consists of 50 individually addressable LED nodes, featuring dynamic integration of power, communication, and control. The flexible form factor accommodates two- and three-dimensional configurations, while high light output affords superior long-distance viewing for architectural accent and perimeter lighting, large-scale signage, and building-covering video displays.

- Multiple lens options — Clear flat and translucent dome lenses are standard. Optional marquee lenses, available in clear, semi-frosted, and translucent, snap onto flat-lens nodes to create the appearance of bulbs on a traditional theatre marquee. You can mount marquee lenses in front of a substrate or directly to mounted strands.
- Adaptable mounting — iColor Flex LMX gen2 strands can be mounted directly to a surface like traditional string lights. Detachable leader cables in multiple lengths allow you to install strings at the appropriate distance from power / data supplies. Optional mounting tracks ensure straight linear runs, while snap-on spacers hide cabling and mounting hardware between nodes for a clean, finished look. Single node mounts can be positioned individually to provide anchor points for installations with uneven node spacing or complex geometries. Optional glare shields can block unwanted spill light or prevent light sources from being visible in certain applications.
- Standard and custom lengths and node spacing — Standard on-center node spacing of 4 in (102 mm) or 12 in (305 mm) and custom spacing from 3 in (76 mm) to 24 in (610 mm) support virtually any lighting or video design. Standard 50-node strands can be field-shortened. Custom lengths of 5 to 60 nodes are also available.
- Custom Leader Cables — Custom Leader Cable lengths are available in addition to standard cables of 25 ft (7.6 m), 50 ft (15.2 m), and 100 ft (30.5 m).
- Industry-leading controls — iColor Flex LMX gen2 works seamlessly with the complete Philips line of controllers, including Video System Manager Pro, Light System Manager, and iPlayer 3, as well as third-party DMX controllers.
- Outdoor rated — Fully sealed for maximum fixture life and IP66-rated for outdoor applications.



### Daylight Visible

iColor Flex LMX gen2 strands consist of 50 large, individually controllable, high-intensity LED nodes. Each node produces full-color light output of up to 11 candela.

## Neither Rain Nor Hail Nor Heat of Day . . .

Artists Laura Garanzuay and Connie Arismendi achieved their aesthetic vision with the help of Philips Color Kinetics LED lighting systems and Philips Color Kinetics Applications Engineering (AE) resources.

Garanzuay and Arismendi won a statewide competition conducted by the Fort Worth Public Art program to create an art installation for a radio tower that carries public safety communications for the City of Fort Worth, Texas, USA, and other agencies. Their concept was to emulate the look of a 1930s RKO radio tower logo with rings of light symbolic of radio waves.

The artists soon found that there were many technical, environmental, and physical limitations on their design. The sculpture would have to be placed at intervals so as not to interfere with transmissions. The lighting system would have to withstand extremely harsh conditions — seventy-mile-per-hour winds, lightning strikes, half-inch radial hail, freezing rain, and temperature variations from 110° F to freezing within the same day. The radio tower was designed to support the light sculpture, but to avoid possible maintenance issues, the lighting system could not make direct contact with the metal surface. A Teflon strip separates the metal structure from the lighting system creating an insulating barrier.

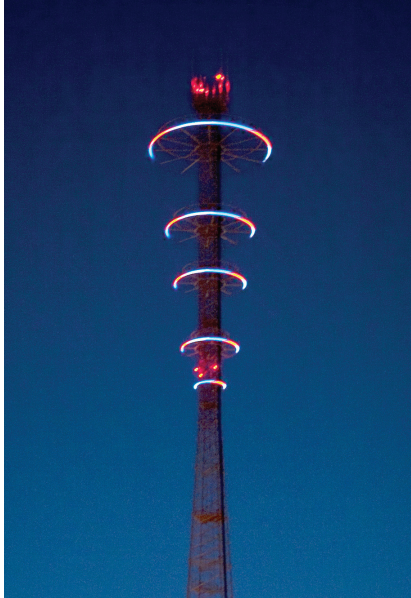

Photography: Ralph Lauer



The Philips Color Kinetics AE team recommended 31 strings of iColor Flex SLX (now specified using iColor Flex LMX gen2) and a Light System Manager controller to create the symbolic radio waves. The AEs worked closely with onsite engineers to ensure compliance with specifications and to solve technical challenges. For example, they recommended the use of fiber optic cabling when the distances between the fixtures, power supplies, and controller proved to be too long for Ethernet cabling.

An onsite AE programmed the lighting system to achieve lighting effects and animation sequences under direction from the artists. “The AE service contributions are what really brought this project to the modern era. It was a great collaboration and took the aesthetics to a new level, beyond our initial design.” said Arismendi.

“We have used Philips Color Kinetics on other projects and they consistently exceed our expectations. Their commitment to service helps us reach new levels in design and go beyond what we could do ourselves. We have confidence in Philips Color Kinetics and in turn our clients have confidence in us. They are a true partner, committed to our success.”

# Specifications

Due to continuous improvements and innovations, specifications may change without notice.

Item	Specification	Clear Flat Lens	Translucent Dome Lens
Output	Lumens Per Node*	30	13
	On-Axis Candela Per Node	11.0	2.2
	Luminance Per Node	17,004 cd / m <sup>2</sup>	3,450 cd / m <sup>2</sup>
	Viewing Angle	105°	165°
	Lumen Maintenance†	60,000 hours L70 @ 50° C 60,000 hours L50 @ 50° C	60,000 hours L70 @ 25° C 60,000 hours L50 @ 25° C
	LED Channels	Red / Green / Blue	
Electrical	Input Voltage	24 VDC via sPDS-480ca, PDS-60ca, and sPDS-60ca	
	Power Consumption	1 W max. per node at full output, steady state	
Control	Interface	sPDS-60ca 24 V (DMX / Ethernet) PDS-60ca 24V (Pre-programmed, DMX, or Ethernet) PDS-480ca 24V (Ethernet)	
	Control System	Philips full range of controllers, including Video System Manager Pro, Light System Manager, and iPlayer 3, or third-party controllers	
Physical	Node Dimensions (Height x Width x Depth)	1.2 x 1.25 x .67 in (31 x 32 x 17 mm)	1.2 x 1.25 x 1 in (31 x 32 x 25 mm)
	Weight	2.2 lb (1 kg) 50-node strand, 4 in on-center node spacing	
	Housing	White or black polycarbonate	
	Lens	Clear or translucent plastic	
	Fixture Connections	Integrated watertight 3-pin connector	
	Temperature Ranges	-40° – 122° F (-40° – 50° C) Operating ≥ 32° F (≥ 0° C) Handling -4° – 122° F (-20° – 50° C) Startup -22° – 185° F (-30° – 85° C) Storage	
Certification and Safety	Certification	UL / cUL, FCC Class A, CE	
	Environment	Dry / Damp / Wet Location, IP66	
	Humidity	0 – 95%, non-condensing	
Maximum Fixtures Per Power / Data Supply	sPDS-480ca 24V:	8 strands	
	sPDS-60ca 24V:	1 strand	
	PDS-60ca 24V:	1 strand	

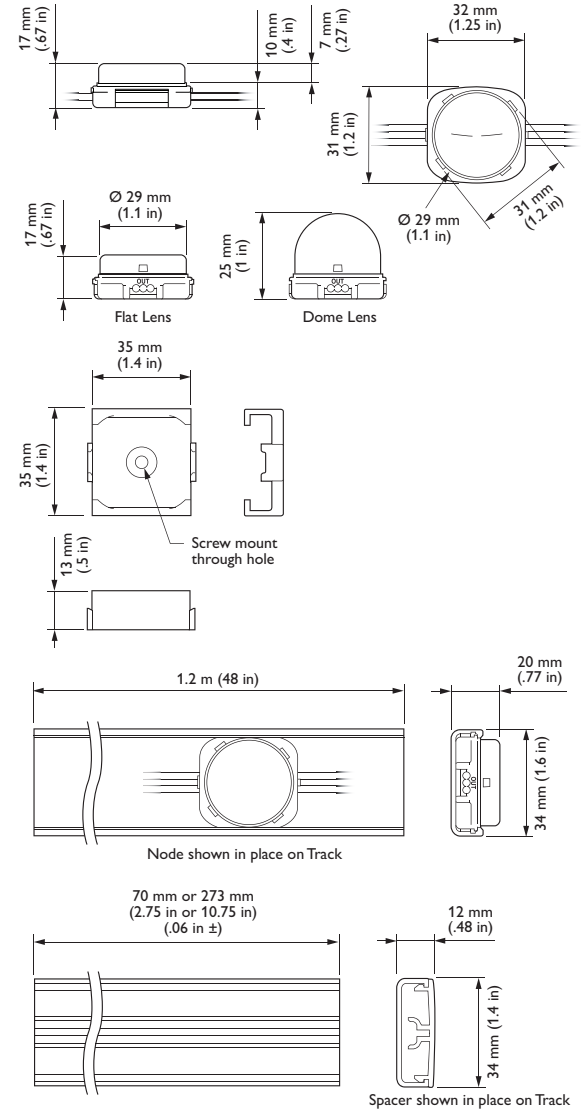

\* Lumen measurement complies with IES LM-79-08 testing procedures.

† L70 = 70% lumen maintenance (when light output drops below 70% of initial output).

L50 = 50% lumen maintenance (when light output drops below 50% of initial output).

Ambient luminaire temperatures specified. Lumen maintenance calculations are based on lifetime prediction graphs supplied by LED source manufacturers. Calculations for white-light LED fixtures are based on measurements that comply with IES LM-80-08 testing procedures. Refer to [www.philipscolorkinetics.com/support/appnotes/lm-80-08.pdf](http://www.philipscolorkinetics.com/support/appnotes/lm-80-08.pdf) for more information.



# Fixtures and Power / Data Supplies

## Included in the box

iColor Flex LMX gen2 strand (50 nodes)
Extra termination cap
Installation Instructions

## Custom Configurations

In addition to the standard configurations listed here, custom configurations are also available. See the iColor Flex LMX gen2 Ordering Information sheet at [www.philipscolorkinetics.com/lis/rgb/flexlmx/](http://www.philipscolorkinetics.com/lis/rgb/flexlmx/) for complete information.

Component	Available Non-Standard Options
Node Spacing	3 in (76 mm) – 24 in (610 mm) on-center
Strand Length	5 – 60 nodes
Node / Cable Color	Clear
Lens	Semi-frosted flat, semi-frosted dome

iColor Flex LMX gen2 is part of a complete system which includes fixtures and:

- One or more power / data supplies
- One Leader Cable to attach each strand to a power / data supply port
- Optional mounting tracks, spacers, single node mounts, glare shields, and marquee lenses
- Any Philips controller, including Video System Manager, Light System Manager, and iPlayer 3, or third-party controller

Item	Type		Item Number	Philips 12NC
iColor Flex LMX gen2 4 in on-center node spacing	Clear Flat Lens	White	101-000077-02	912400130024
		Black	101-000077-00	910503705491
	Translucent Dome Lens	White	101-000077-06	912400130028
		Black	101-000077-04	912400130026
iColor Flex LMX gen2 12 in on-center node spacing	Clear Flat Lens	White	101-000077-03	912400130025
		Black	101-000077-01	912400130023
	Translucent Dome Lens	White	101-000077-07	912400130029
		Black	101-000077-05	912400130027
Leader Cable	25 ft (7.6 m)	Black	108-000045-00	910503700696
	50 ft (15.2 m)	Black	108-000045-01	910503700697
	100 ft (30.5 m)	Black	108-000045-02	910503700698
Mounting Track Qty 1	4 ft (1.2 m)	White	101-000057-00	910503700044
		Black	101-000057-01	910503700045
Spacers Qty 50	4 in (102 mm)	White	101-000059-00	910503700048
		Black	101-000061-00	910503700052
	12 in (305 mm)	White	101-000059-01	910503700049
		Black	101-000061-01	910503700053
Single-Node Mounts Qty 50		White	101-000058-00	910503700046
		Black	101-000058-01	910503700047
sPDS-480ca 24V	Ethernet		109-000026-00	910503700110
PDS-60ca 24V	Pre-programmed		109-000016-00	910503700095
	DMX		109-000016-01	910503700333
	Ethernet		109-000016-02	910503700334
sPDS-60ca 24V	DMX / Ethernet		109-000021-02	910503700106

Use Item Number when ordering in North America.

# Accessories

Item	Type		Item Number	Philips 12NC
Marquee Lens Kits Qty 50	Clear	White	999-007997-00	910503702308
		Black	999-007997-01	910503702309
	Semi-Frosted	White	999-007997-04	910503702312
		Black	999-007997-05	910503702313
	Translucent	White	999-007997-02	910503702310
		Black	999-007997-03	910503702311
Glare Shield Kits Qty 50		Black	120-000179-00	912400130036
Accessory Mounting Track Qty 1	4 ft (1.2 m)	White	101-000057-03	910503704266
		Black	101-000057-04	910503704267
Accessory Spacers Qty 50	4 in (102 mm)	White	101-000075-00	910503704272
		Black	101-000075-02	910503704274
	12 in (305 mm)	White	101-000075-01	910503704273
		Black	101-000075-03	910503704275

Use Item Number when ordering in North America.

## Marquee Lenses



**Clear**



**Semi-Frosted**



**Translucent**

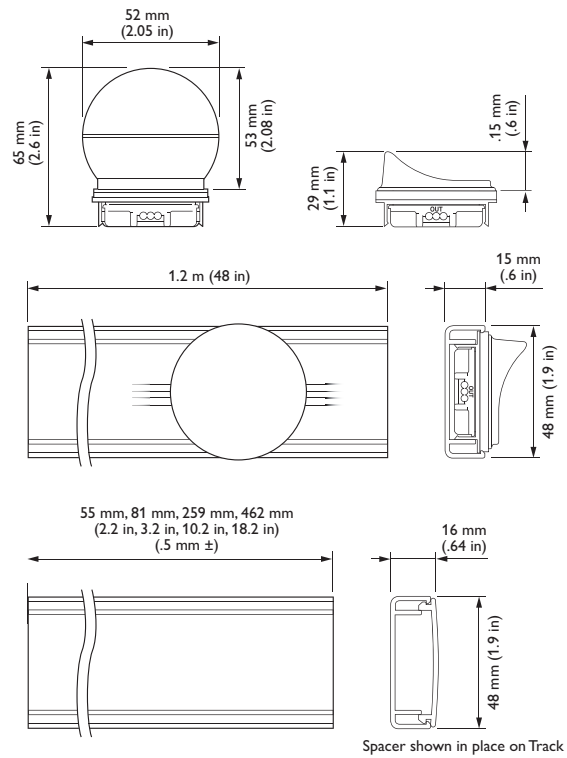

# Installation

iColor Flex LMX gen2 can be used in a wide range of two-dimensional and three-dimensional configurations, including portable video screens and permanent building-covering displays. iColor Flex LMX gen2 installations are not constrained by fixture size, shape, or architectural space. For example, iColor Flex LMX gen2 strands can be wrapped horizontally around the exterior of a 45-story highrise at intervals to transform the façade into a massive three-dimensional video screen that can be viewed from a distance.

✳️ *Clean lenses with water and mild detergent using a soft cleaning cloth. Wipe lenses dry. Do not use paper towels, abrasive cleaning products, or window cleaners. Abrasive cleaning products will scratch lenses, and window cleaners will soften and mar the polycarbonate. Do not use cleaning solutions that contain ammonia, sodium hydroxide, or isopropyl alcohol, which can scratch, pit, haze, yellow, or crack lenses*

Because of their potential complexity, iColor Flex LMX gen2 installations require upfront planning for configuring, positioning, and mounting the fixture strands. Planning includes understanding how to position strands in relation to power / data supplies and the number of strands each power / data supply can support. Planning for video displays involves additional considerations, such as how to space iColor Flex LMX gen2 nodes to achieve the desired pixel pitch, minimum and maximum viewing distances, sampling, and display resolution.

All installations involve three main steps:

1. Create a lighting design plan and layout grid
2. Mount fixture strands
3. Address, configure, and test fixtures

## Owner / User Responsibilities

It is the responsibility of the contractor, installer, purchaser, owner, and user to install, maintain, and operate iColor Flex LMX gen2 fixtures in such a manner as to comply with all applicable codes, state and local laws, ordinances, and regulations. Consult with the appropriate electrical inspector to ensure compliance.

## Installing in Damp or Wet Locations

When installing in damp or wet locations, seal all fixture connections, power / data supplies, and junction boxes with electronics-grade RTV silicone sealant so that water or moisture cannot enter or accumulate in wiring compartments, cables, or other electrical parts. Use suitable outdoor-rated junction boxes when installing in wet or damp locations. Additionally, use gaskets, clamps, and other parts required for installation to comply with all applicable local and national codes.

## DMX or Ethernet Control?

iColor Flex LMX gen2 installations can be controlled via either DMX or Ethernet. DMX is appropriate for relatively simple installations, or for installations where all lights operate in unison — for example, for accenting, perimeter lighting, or cove lighting applications.

Each node in a strand of iColor Flex LMX gen2 is identified by a *light number*. A light number corresponds to three sequential DMX addresses, one for red, one for green, and one for blue. A DMX universe consists of 512 addresses, so the maximum number of light numbers available in a DMX universe is 170 ( $170 \times 3 = 510$ ).

Because it is not subject to the DMX addressing limitations, Ethernet is the preferred environment for dynamic, color-changing light shows and video displays, both of which require large numbers of unique light numbers. In an Ethernet environment, each power / data supply effectively acts as its own universe.

DMX installations require the use of a PDS-60ca 24V or sPDS-60ca 24V power / data supply, while the PDS-480ca 24V power / data supply is Ethernet-only.

✳️ *Refer to the iColor Flex LMX gen2 Installation Instructions for specific warning and caution statements.*

# Considerations for Video Displays

In addition to the planning required for all iColor Flex LMX gen2 installations, planning for video displays involves special considerations such as pixel pitch, minimum and maximum viewing distances, sampling, and display resolution.

## Determining Pixel Pitch and Viewing Distances for Video Displays

When using iColor Flex LMX gen2 strands to display video, each node acts as a pixel in the display. Images on an LED video display appear to be sharper to the human eye as the distance to the display increases. Likewise, images appear less visible as the distance decreases. The spacing between pixels, known as the *pixel pitch*, determines the minimum and maximum viewing distances for discernible video output. Pixel pitch is measured center-to-center. For an iColor Flex LMX gen2 strand, you determine pixel pitch by measuring from the center of one node to the center of the next.

Designing a layout with overlapping strands is a common technique for increasing pixel pitch. For example, to create a dense line of nodes, place multiple runs close to each other vertically, with a slight horizontal offset between the nodes. Philips offers strands with both 4 in (102 mm) and 12 in (305 mm) spacing between nodes. Using strands with made-to-order node spacing is another method for adjusting pixel pitch.

The following calculations and examples are general guidelines for determining minimum and maximum viewing distances, based on video displays using grids of evenly spaced pixels:

- To determine minimum viewing distance, multiply pixel pitch by 100 distance units. For example, if the pixel pitch is 2 in (50 mm), the minimum viewing distance is 16.4 ft (5 m).
- To determine the maximum viewing distance for discernible video, multiply the screen height by 20 distance units. For example, if the screen height is 65.6 ft (20 m), then the maximum viewing distance for recognizable video is 1312.3 ft (400 m).
- LED screens are visible beyond the maximum viewing distance for discernible video. To determine the maximum viewing distance that still creates visual impact, multiply the screen height by 50 units. For example, a screen 65.6 ft (20 m) high will continue to create visual impact at 3280.8 ft (1000 m).

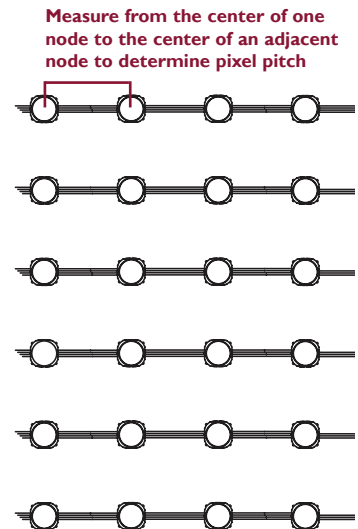

## Working with Video Display Resolutions

The resolution of an LED video display equals the total number of vertical and horizontal pixels — the greater the pixel count, the greater the resolution.

- The resolution of VSE digital video is 1024 x 768
- The resolution of PAL video is 704 x 576
- The resolution of NTSC video is 704 x 480

⊗ VSE Pro, or Video System Engine Pro, is the hardware component of Video System Manager Pro, an integrated video controller from Philips Color Kinetics. Visit [www.philipscolorkinetics.com/ls/controllers/vsmpro/](http://www.philipscolorkinetics.com/ls/controllers/vsmpro/) for complete information.

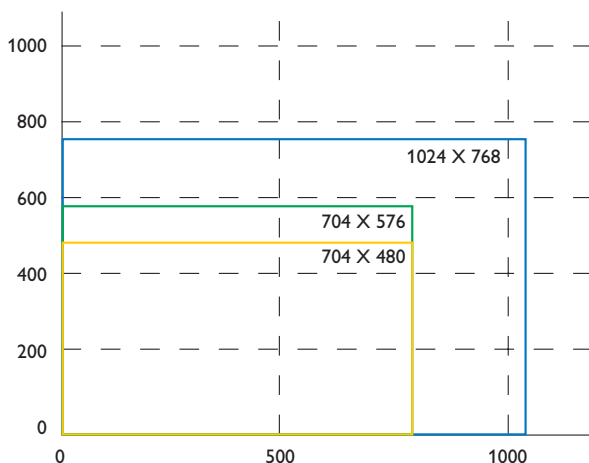



✳ For designs where the acceptable level of discernible video may be more or less demanding, or for help with your specific installation, contact Philips Color Kinetics Application Engineering Services for assistance.

Reproducing a video signal with 1:1 pixel mapping on an LED display requires a substantial pixel count. For example, true NTSC video output requires 337,920 pixels, PAL output requires 405,504 pixels, and digital video output requires 786,432 pixels.

However, you can use a controller such as Philips Video System Manager Pro to reduce the required pixel count for any video format by sampling and distributing pixels from the source video to match your installation.

For example, if you retain the horizontal resolution of a digital video source (1024 lines wide), but sample every tenth line of pixels vertically (76 lines high instead of 768 lines), you can retain the correct aspect ratio while exponentially reducing the pixel count. From a distance, even with only 76 lines of vertical output, the human eye can still discern video images because the horizontal resolution is dense.

An installation using 1024 x 76 nodes would have a pixel count of 77,824 yet still display high-quality digital video output. This method is especially effective when creating an installation that covers a building which, by necessity, already has spacing between lines of video due to windows and other architectural features.

## Create a Lighting Design Plan and Layout Grid

Even for relatively simple installations, it's good practice to create a lighting design plan. For complex installations displaying light shows with dynamic effects, and especially for Ethernet-based video displays, such a plan is essential. A lighting design plan is typically an architectural diagram or other diagram that shows the physical layout of the installation, including the appropriate positioning and spacing of all fixtures, power / data supplies, power sources, controllers, cables, and other required hardware. For DMX installations, the plan should record the DMX base number and node count for each iColor Flex LMX gen2 strand. For Ethernet installations, the plan should record the IP address of each power / data supply and the number of nodes per power / data supply port.

Keep the following considerations in mind when creating a lighting design plan and layout grid:

- Determine the appropriate location of each power / data supply in relation to the fixtures, and of the fixtures in relation to each other. You connect a strand of iColor Flex LMX gen2 nodes to an available power / data supply port using a Leader Cable of 25 ft (7.6 m), 50 ft (15.2 m), or 100 ft (30.5 m).
- iColor Flex LMX gen2 Leader Cables can be shortened, and strands can be cut to any node length. An extra termination cap is included for sealing the cut end of the strand.

Do not trim the Leader Cable between the power / data supply connector and the PCA transmitter junction box. Do not trim strands between the connector and the first node.

✳ Refer to the Installation Instructions or Specification Sheet of your power / data supply for guidelines on configuring and positioning the power / data supply in relation to a controller or Ethernet switch.

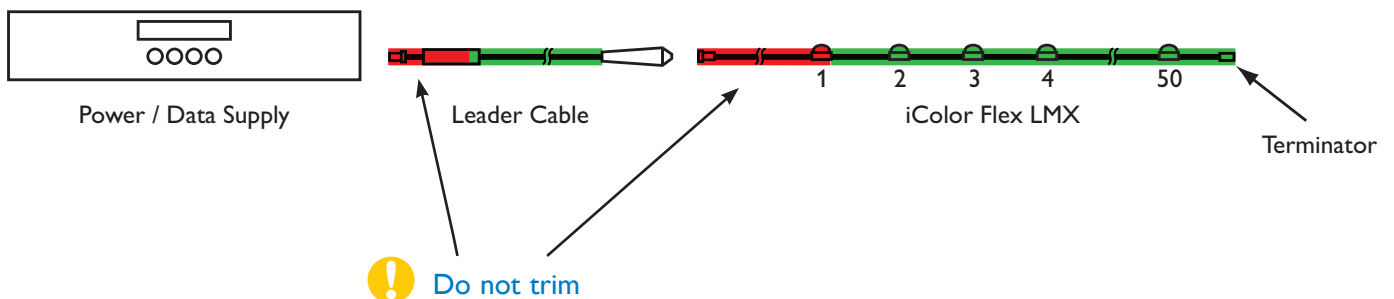

- On an architectural diagram or other diagram that shows the physical layout of the installation, identify the locations of all switches, controllers, power supplies, and fixtures.
- Nodes in each strand are sequentially addressed beginning with the node closest to the Leader Cable. Orientation of the power / data supply is therefore especially critical when using dynamic effects.
- In Ethernet environments, each power / data supply is identified with a unique IP address. We recommend recording the IP address of each power / data supply on a layout grid. For complex installations with many power / data supplies, we recommend assigning meaningful IP addresses to each power / data supply so that their locations are easy to identify.

## Start the Installation

1. Install all power / data supplies, including any interfaces with controllers. Power / data supplies send power and control signals to fixtures over the Leader Cable.
2. Verify that all additional supporting equipment (switches, controllers) is in place.
3. Ensure that all additional parts (for example, optional single node mounts, spacers, mounting track, and mounting hardware) and tools are available.

## Cut and Seal iColor Flex LMX gen2 Strands (Optional)

You can cut iColor Flex LMX gen2 strands to any desired node length. We recommend cutting and sealing the strands before mounting them.

1. Using a wire cutter, cut the cable to the desired length, leaving at least 1 in (25 mm) of cable after the last node. Ensure that the cut is clean and that there are no frayed wires touching other wires.

 Never cut a strand between the three-pin connector and the first node.

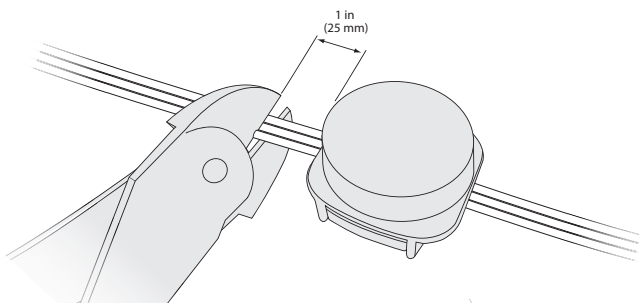

2. Apply a liberal amount of electronics-grade RTV silicone to the cable ends and to the opening of the rubber seal boot included with the extra termination cap. Insert the boot onto the cable.
3. Sit the sealed cable boot into the base of the provided termination cap.
4. Firmly press the termination cap onto the base until the top snaps into place. If using pliers, be careful not to crack the housing.

 Never reuse a used termination cap.

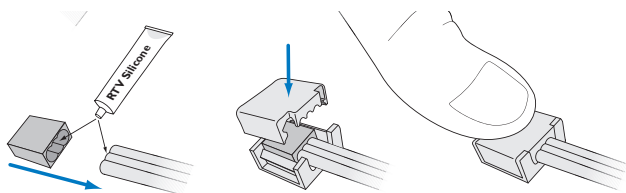

# Mount iColor Flex LMX gen2 Strands

You can mount iColor Flex LMX gen2 strands directly to a mounting surface, or you can mount them using optional mounting hardware (available separately):

- Mounting tracks ensure straight runs in linear applications. If using strands with standard 4-in or 12-in on-center spacing, you can snap spacers to the mounting tracks for a clean, finished look that hides cables and mounting hardware between nodes.
- Single node mounts can be positioned individually to provide anchor points for nodes in installations with uneven node spacing or complex geometries.

Make sure the power is OFF before mounting and connecting iColor Flex LMX gen2.

\* Optional Marquee Lens and Glare Shield Kits use their own mounting tracks and spacers. Refer to “Mount Strands with Accessories” below for details.

\* You cannot use single-node mounts with marquee lenses or glare shields.

## Do not twist or loop cable

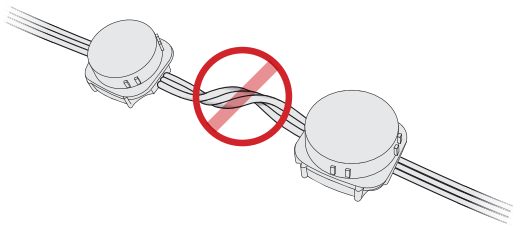

## Do not overstretch cable

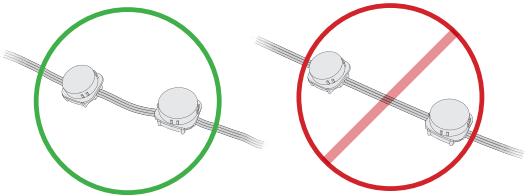

## Do not pull cable away from node

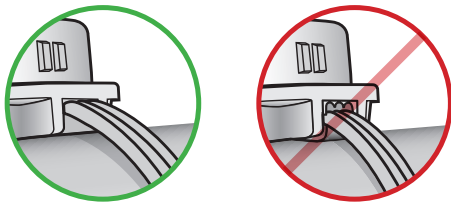

## Use caution when handling cable in sub-freezing temperatures



## Mounting iColor Flex LMX gen2 Strands Directly to a Mounting Surface

1. Using a pencil or chalk line, mark a center-line path for the nodes to follow.
2. Fasten iColor Flex LMX gen2 strands to the mounting surface using a suitable mounting method. For example, you can mount strands to a pipe or cable using plastic cable ties.

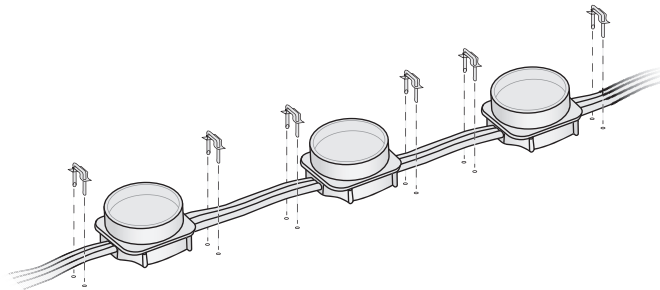

## Mounting iColor Flex LMX gen2 Strands Using Mounting Track

1. Cut mounting track to the desired length with a saw or snips.
2. Using flathead screws suitable for the mounting surface, drive screws through the plastic track into the attaching surface. Recommended maximum spacing between screws is 16 in (406 mm).
3. Snap the iColor Flex LMX gen2 nodes into the mounting track.
3. If using strands with standard 4-in or 12-in on-center spacing, snap optional spacers into the track to hide mounting hardware and wires.

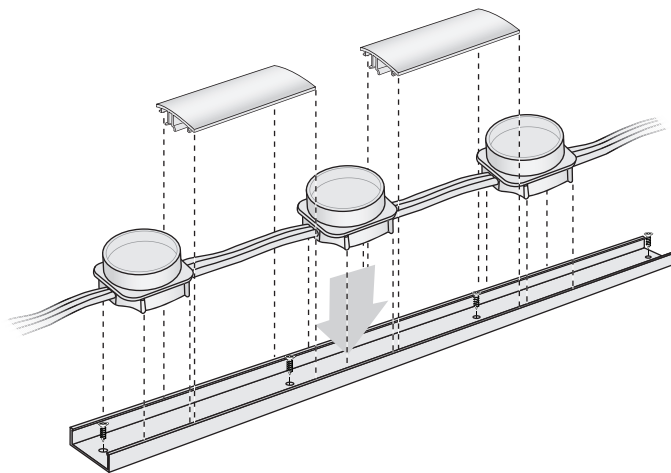

### Mounting iColor Flex LMX gen2 Strands Single-Node Mounts

1. Ensure that the spacing between single node mounts is sufficient to accommodate cable length between nodes and to allow for cable bending as necessary.
2. Using double-sided tape on the base of the mounts, adhere the mounts to the attaching surface. Reinforce installation with #6 flathead screws suitable for the mounting surface.
3. Snap the iColor Flex LMX gen2 nodes into the mounts.

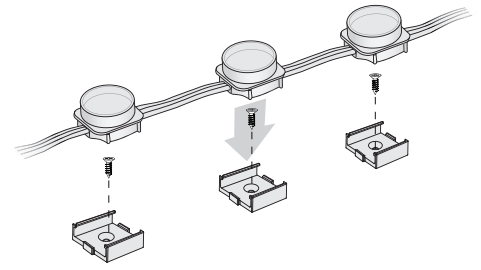

## Mount iColor Flex LMX gen2 Strands with Accessories (Optional)

Marquee lenses and glare shields clip onto iColor Flex LMX gen2 strands with flat lenses. Available with clear, semi-frosted, or translucent finishes, marquee lenses create the appearance of bulbs on a traditional theatre marquee. Glare shields block unwanted spill light, and can shield the light sources from being directly visible in certain mounting situations.

You can mount strands with marquee lenses and glare shields directly to a mounting surface, in front of a substrate, or using optional Accessory Mounting Tracks and Accessory Spacers. Mounting tracks ensure straight runs in linear applications. If using strands with standard 4-in or 12-in on-center spacing, you can snap spacers to the mounting tracks for a clean, finished look that hides cables and mounting hardware between nodes.

### Mounting iColor Flex LMX gen2 Strands with Accessories Directly to a Mounting Surface

1. Using a pencil or chalk line, mark a center-line path for the nodes to follow.
2. Clip a lens or glare shield holder over each iColor Flex LMX gen2 node.
3. Do one of the following:
  - Screw a marquee lens onto the lens holder. Hand tighten to approximately 10 to 15 in-lbs (1.1 to 1.7 Nm).
  - Align the tabs on the glare shield with the slots in the glare shield holder, and snap the glare shield onto the glare shield holder.
3. Fasten assembled iColor Flex LMX gen2 strands to the mounting surface using a suitable mounting method. For example, you can mount strands to a pipe or cable using plastic cable ties.

**\*** You cannot use iColor Flex LMX gen2 accessories on strands with with dome lenses, or when standard mounting tracks or single node mounts..You can install either a marquee lens or glare shield on a node, but not both.

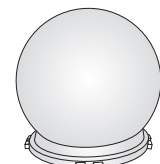
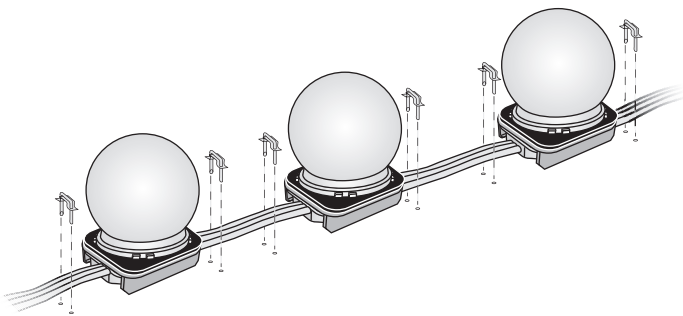

2.125 in Diameter  
(54 mm)

**Marquee Lens Kit**

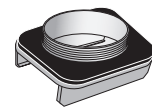

2.125 in Diameter  
(54 mm)

**Glare Shield Kit**

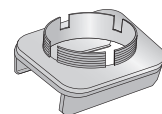

## Mounting iColor Flex LMX gen2 Strands with Accessories in Front of a Substrate

1. Prepare the substrate by cutting openings of the appropriate diameter in the required locations.

To accommodate the threads on the marquee lens holder or the ridges on the glare shield holder, the recommended substrate thickness is .0625 in (1.6 mm), and the maximum thickness is .125 in (3.2 mm). We recommend using a 1 3/8 in diameter hole saw to cut openings in the substrate. Openings should be a minimum of 1.4 in (35.6 mm) in diameter, and a maximum of 1.5 in (38 mm) in diameter.

2. Peel the backing from a lens or glare shield holder to expose the adhesive surface.

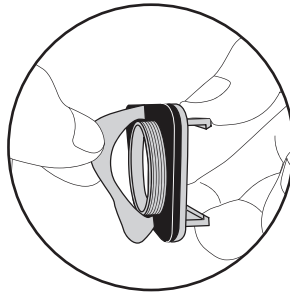

3. Insert the lens or glare shield holder through an opening in the substrate, and temporarily affix the lens holder by pressing the adhesive surface to the back of the substrate. Make sure that the holder is oriented in the direction of the iColor Flex LMX gen2 strand.

.0625 in (1.6 mm) recommended  
.125 in (3.2 mm) max

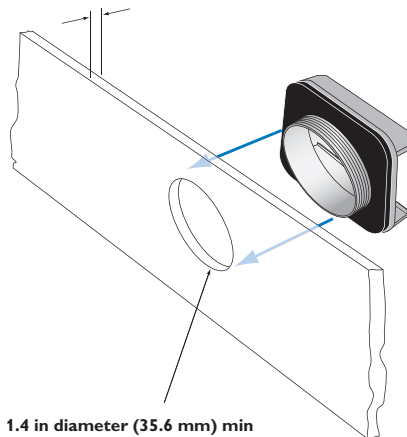

1.4 in diameter (35.6 mm) min  
1.5 in diameter (38 mm) max  
1 3/8 in diameter hole saw recommended

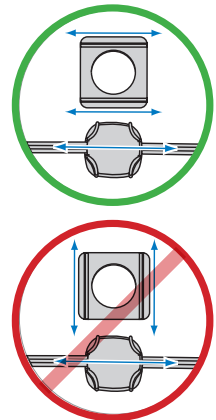

4. Do one of the following:

- Screw a marquee lens onto the lens holder. Hand tighten to approximately 10 to 15 in-lbs (1.1 to 1.7 Nm).

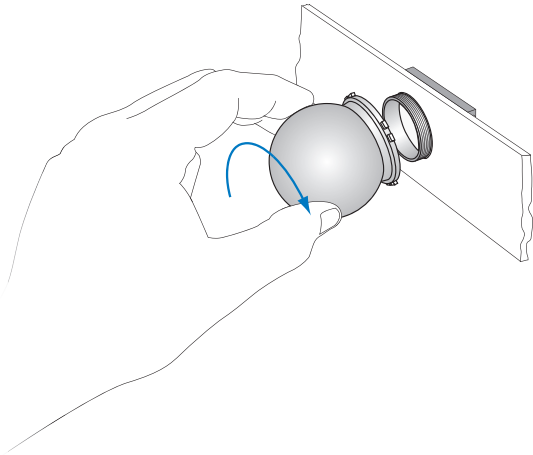

- Align the tabs on the glare shield with the slots in the glare shield holder, and snap the glare shield onto the glare shield holder.

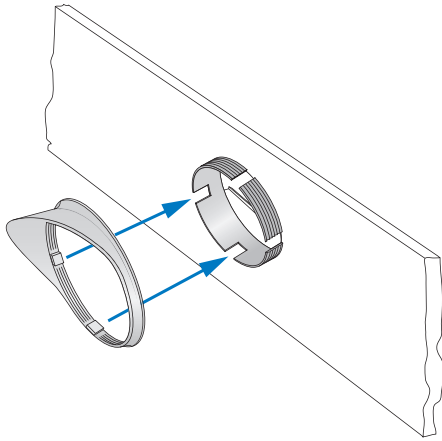

5. Repeat steps 2 – 4 for each opening.

6. Once all accessories are installed on the substrate, mount iColor Flex LMX gen2 strands by inserting one node into the back of each lens or glare shield holder. Press until the nodes snap firmly into the lens or glare shield holders.

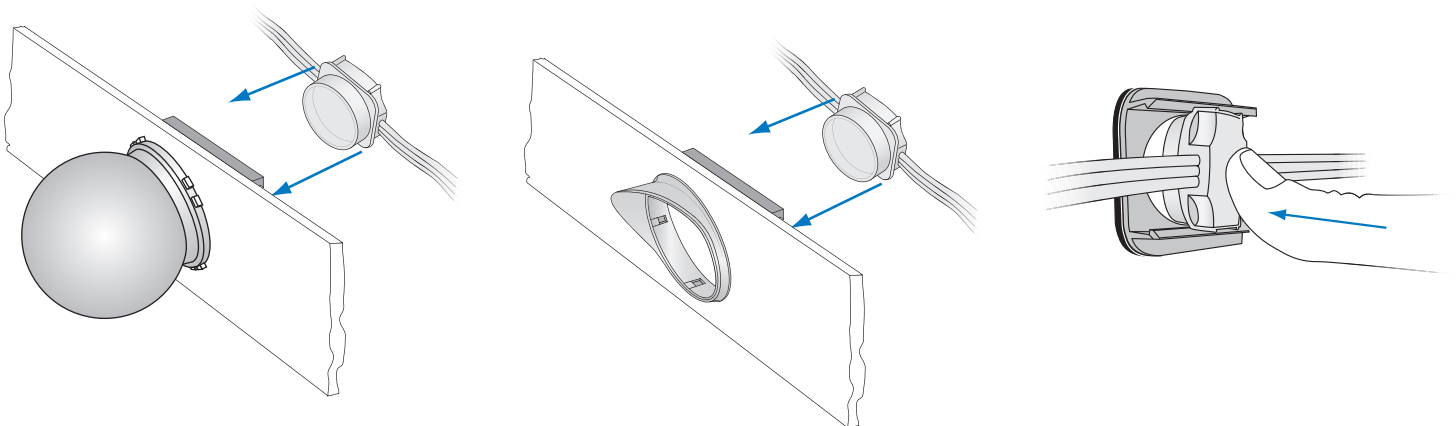

## Mounting Marquee Lenses and Glare Shields to Accessory Mounting Track

1. Clip a lens or glare shield holder to each node.
2. Do one of the following:
  - Screw a marquee lens onto the lens holder. Hand tighten to approximately 10 to 15 in-lbs (1.1 to 1.7 Nm).
  - Align the tabs on the glare shield with the slots in the glare shield holder, and snap the glare shield onto the glare shield holder.
3. Cut the Accessory Mounting Track to the desired length with a saw or snips. Using flathead screws suitable for the mounting surface, drive screws through the plastic track into the attaching surface. Recommended maximum spacing between screws is 16 in (406 mm).
4. Snap the assembled iColor Flex LMX gen2 nodes into the mounting track.
5. If using strands with standard 4-in or 12-in on-center spacing, you can snap optional Accessory Spacers into the track to hide mounting hardware and wires.

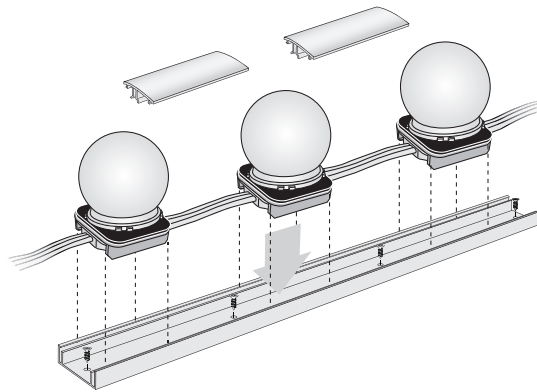

## Make Power and Data Connections

iColor Flex LMX gen2 fixtures are designed to work with 24 VDC power / data supplies from Philips Color Kinetics. Power / data supplies send power and data to iColor Flex LMX gen2 strands over a Leader Cable.

PDS-60ca 24V is an IP66-rated power / data supply, suitable for use in damp and wet locations. Although sPDS-480ca 24V and sPDS-60ca 24V are rated for use in dry locations only, you can install them in watertight enclosures for outdoor applications.

Make sure the power is OFF before connecting iColor Flex LMX gen2 strands.

### Maximum strands per power / data supply

PDS-60ca 24V	1
sPDS-60ca 24V	1
sPDS-480ca 24V	8

### Connecting iColor Flex LMX gen2 Leader Cables

Connect a Leader Cable to the three-pin connector on the end of each iColor Flex LMX gen2 strand by turning the fixture strand's grommet clockwise. In wet or damp environments, tighten the grommet on the male connector sufficiently to ensure a watertight seal.

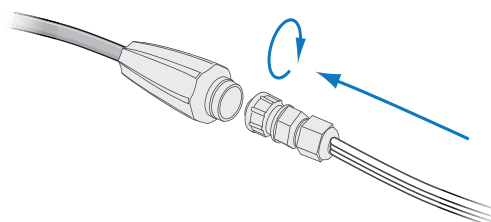
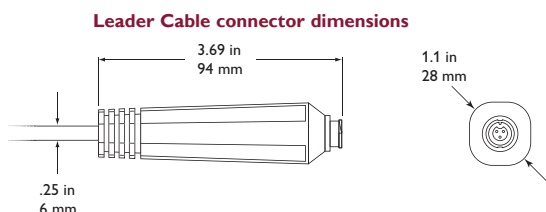

## Connecting to the sPDS-60ca 24V and sPDS-480ca 24V Power / Data Supplies

Connect each Leader Cable to an available power port on the back of a power / data supply housing.

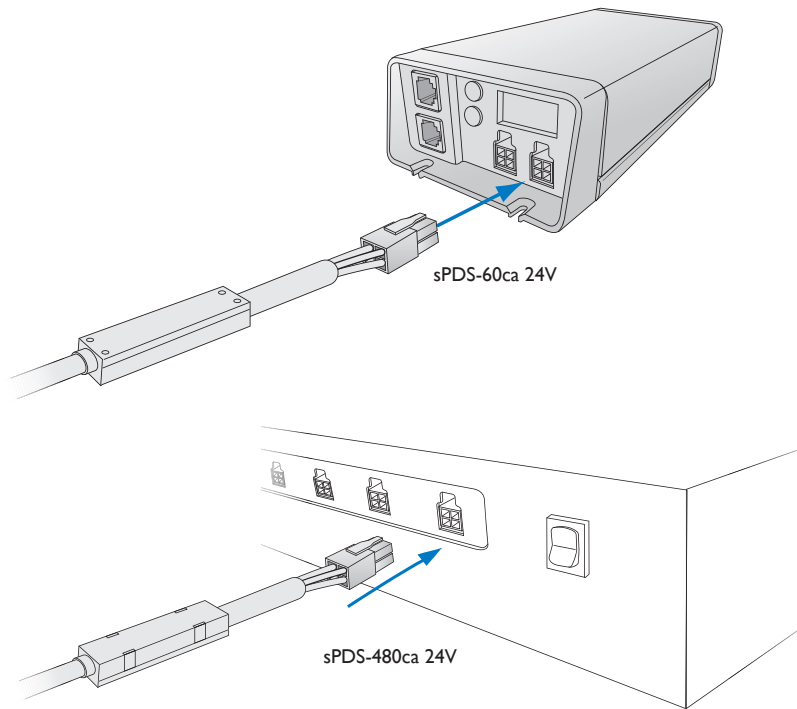

## Connecting to the PDS-60ca 24V Power / Data Supply

The PDS-60ca 24V is an IP66-rated power / data supply, suitable for use in damp and wet locations. The following procedure describes how to connect and seal a PDS-60ca 24V power / data supply for outdoor applications.

1. Remove the power / data supply cover.
2. Remove the cover of the transmitter PCA junction box by expanding the four tabs on the side and sliding the cover from the base.
3. Connect line, common, ground, and data to the provided terminal block, then replace the cover of the transmitter PCA junction box.

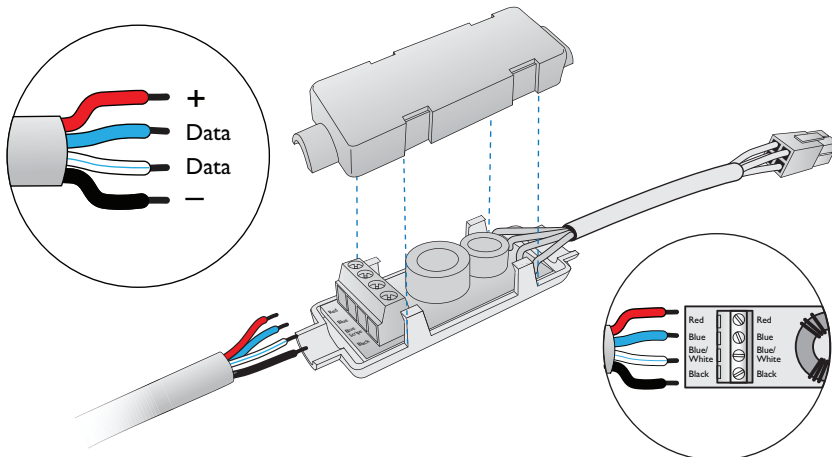

## Transmitter PCA junction box dimensions

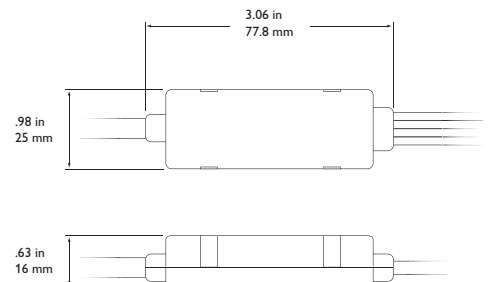



4. Connect the Leader Cable connector to an available port inside the power / data supply housing.

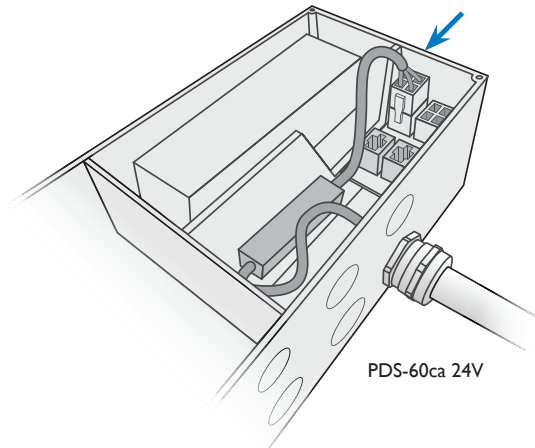

5. Secure the power / data supply cover. If installing in a wet or damp location, seal the power / data supply with electronics-grade RTV silicone sealant.

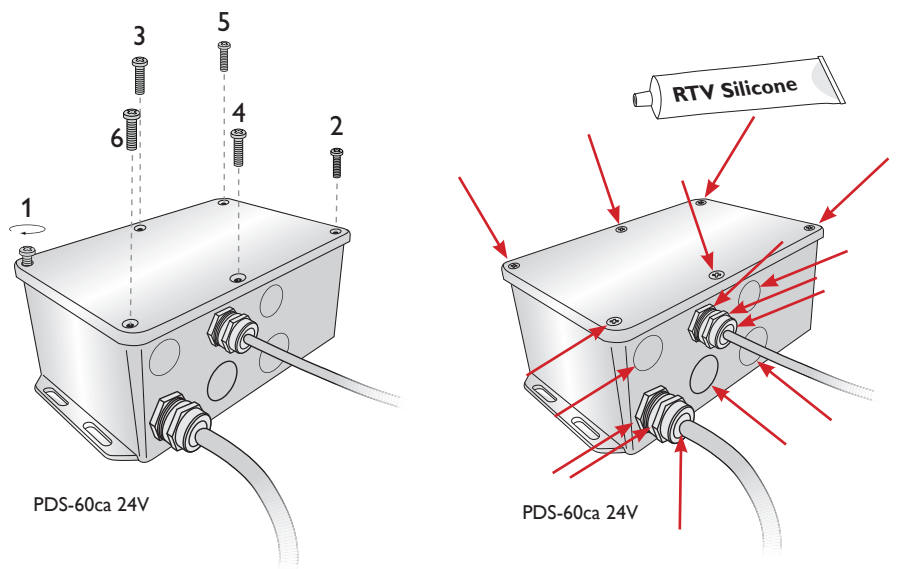

6. Repeat steps 1 – 5 for each power / data supply in the installation.

# Address and Configure the Fixtures

Make sure the power is ON before addressing and configuring fixtures.

Power / data supplies and controllers work together to stream data to the iColor Flex LMX gen2 strands in your installation.

- Each individual iColor Flex LMX gen2 node is assigned three sequential DMX addresses, one for red, one for green, and one for blue. A DMX universe consists of 512 addresses, so the maximum number of iColor Flex LMX gen2 nodes that can be individually addressed in a DMX universe is 170 ( $170 \times 3 = 510$ ).

When using an sPDS-60ca 24V power / data supply with DMX control, you program the power / data supply rather than addressing the iColor Flex LMX gen2 strands directly. You use SmartJack Pro (or iPlayer 3) with QuickPlay Pro addressing software to set a base DMX address for the power / data supply, and to specify the node quantity of each attached iColor Flex LMX gen2 strand.

For lighting designs where nodes work in unison, all nodes should be set to the same DMX addresses. For dynamic light show designs that show different colors on different nodes simultaneously, you must assign unique DMX addresses to each node. Starting with its base DMX address, PDS-60ca automatically assigns addresses to each iColor Flex LMX gen2 node in sequence, from the first node on output port 1 through the last node on output port 2.

- Because you are limited to 170 uniquely addressed nodes per DMX universe (less than four strands of 50 nodes each), Ethernet is the preferred environment for video displays and dynamic light shows with intricate effects.

Each Ethernet-based power / data supply comes pre-programmed with a unique IP address, so the power / data supply effectively functions as its own universe. When creating a light map with a controller or media server such as Light System Manager or Video System Manager Pro, each iColor Flex LMX gen2 node automatically receives a unique identifier.

You can discover all power / data supplies by IP address using QuickPlay Pro, Light System Manager, or Video System Manager Pro. For large installations, and especially for video displays, we recommend giving power / data supplies meaningful IP addresses to streamline installation, mapping, testing, and troubleshooting. When readdressing power / data supplies, you will need the layout grid you created when you recorded each power / data supply's IP address during installation planning.

For complete details on addressing and configuring fixtures, controllers, and power / data supplies, refer to the *Addressing and Configuration Guide* or the *User Guide* or *Specification Sheet* for your controller or power / data supply.

 You can download the QuickPlay Pro software and the Addressing and Configuration Guide from [www.philipscolorkinetics.com/support/addressing/](http://www.philipscolorkinetics.com/support/addressing/).





Philips Color Kinetics  
3 Burlington Woods Drive  
Burlington, Massachusetts 01803 USA  
Tel 888.385.5742  
Tel 617.423.9999  
Fax 617.423.9998  
[www.philipscolorkinetics.com](http://www.philipscolorkinetics.com)

Copyright © 2011 – 2013 Philips Solid-State Lighting Solutions, Inc. All rights reserved.  
Chromacore, Chromasic, CK, the CK logo, Color Kinetics, the Color Kinetics logo, ColorBlast, ColorBlaze, ColorBurst, eW Fuse, ColorGraze, ColorPlay, ColorReach, iW Reach, eW Reach, DIMand, EssentialWhite, eW, iColor, iColor Cove, IntelliWhite, iW, iPlayer, Optibin, and Powercore are either registered trademarks or trademarks of Philips Solid-State Lighting Solutions, Inc. in the United States and / or other countries. All other brand or product names are trademarks or registered trademarks of their respective owners. Due to continuous improvements and innovations, specifications may change without notice.  
Cover Photo: Dragon Bridge, Da Nang, Vietnam,  
by Biz Tequilar, Biz Tequilar Agency, partner of Onevoice

DAS-000050-00 R10 10-13