



eW Reach Powercore gen2

Premium long-throw exterior LED floodlight with solid white light

PHILIPS



eW Reach Powercore gen2

Premium long-throw exterior LED floodlight with solid white light

eW Reach Powercore gen2 high-performance LED fixtures are premium exterior long-throw dynamic high-quality white luminaires for lighting tall buildings, bridges, and iconic structures. eW Reach Powercore gen2 outputs washes of white light in color temperatures ranging from a warm 2700 K to a cool 6500 K. A full range of accessories allow for customizable beam angles for floodlighting, spotlighting, wall washing, and grazing, along with the efficiency and cost-effectiveness of Powercore technology in a rugged die-cast aluminum housing.

- Multiple options for design flexibility—Fixtures are available in a warm 2700 K or a cool 4000 K. Custom configurations with custom channels of white or color LED sources are also available from 3000 K to 6500 K to support special applications.
- Superior color consistency and accuracy—Optibin, an advanced binning algorithm, sets a new standard for the color consistency and uniformity of LED sources used in manufacturing resulting in color consistency within 2 SDCM.
- Dimming control via DMX—Dim fixtures smoothly and accurately from 1% to 100% with Philips Color Kinetics lighting controllers, including iPlayer 3, and third-party controllers (optional Data Enabler Pro and 4conductor cable required).
- Expanded customization with a wide range of new Philips accessory options. To complement the native 5° lens, six standard secondary diffuser lenses can customize the fixture to produce 8°, 13°, 23°, 43°, 63°, and 5° x 17° (asymmetric) beam angles. The option to add or combine a louver, full glare shield, or half glare shield creates new aesthetic possibilities for designers and architects.
- Unparalleled light output—eWReach Powercore gen2 offers unprecedented output and punch for LED-based illumination of large-scale structures and objects.
- Integrates patented Powercore technology that controls power output to fixtures directly from line voltage—rapidly, efficiently, and accurately. The Philips Color Kinetics Data Enabler Pro merges line voltage with control data and delivers them to fixtures over a single standard cable, dramatically simplifying installation and lowering total system cost.
- Simple fixture positioning—Rugged, slim-profile mounting bracket allows simple positioning and fixture rotation through a full 360°. Side locking bolts reliably secure fixture with a standard wrench.
- Universal power input range of 100 – 277 VAC.



Unparalleled Light Output

eW Reach Powercore gen2 offers LED-based white light illumination of large-scale structures and objects. New accessories, including a new louver and two glare shields, provide extra flexibility to help with dark sky compliance, discomfort glare, and trespass light.

Photometrics

Photometric data is based on test results from an independent NIST traceable testing lab. IES data is available at www.philipscolorkinetics.com/support/ies.

eW Reach Powercore gen2 2700 K 5° native lens, full unit

Lumens	Efficacy
13,485	56.7

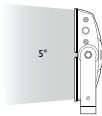

Polar Candela Distribution

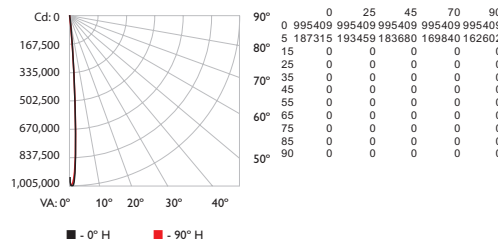

Illuminance at Distance

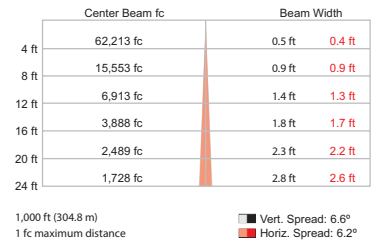

Zonal Lumen

Zone	Lumens	% Luminaire
0-30	13,860.0	100.0%
0-40	13,860.0	100.0%
0-60	13,860.0	100.0%
0-90	13,860.0	100.0%
60-90	0.0	0.0%
70-100	0.0	0.0%
90-120	0.0	0.0%
90-180	0.0	0.0%
0-180	13,860.0	100.0%

Coefficients Of Utilization - Zonal Cavity Method

RCC %:	80	70	50	30	10	0												
RW %:	70	50	30	0	50	30	20	10	0									
RCR:	0	1	2	3	4	5	6	7	8	9	10							
0	1.19	1.19	1.19	1.19	1.16	1.16	1.16	1.00	1.11	1.11	1.11	1.06	1.06	1.06	1.02	1.02	1.02	1.00
1	1.17	1.15	1.14	1.13	1.14	1.13	1.12	1.00	1.09	1.08	1.08	1.06	1.05	1.05	1.02	1.02	1.02	1.00
2	1.15	1.12	1.11	1.09	1.13	1.11	1.09	1.00	1.08	1.07	1.05	1.05	1.04	1.03	1.03	1.02	1.01	1.00
3	1.13	1.10	1.08	1.06	1.12	1.09	1.07	1.00	1.07	1.05	1.04	1.05	1.03	1.02	1.03	1.02	1.01	1.00
4	1.12	1.09	1.06	1.05	1.11	1.08	1.06	1.00	1.06	1.04	1.03	1.04	1.03	1.02	1.03	1.02	1.01	1.00
5	1.11	1.07	1.05	1.04	1.10	1.07	1.05	1.00	1.05	1.04	1.02	1.04	1.03	1.02	1.03	1.02	1.01	1.00
6	1.10	1.07	1.04	1.03	1.09	1.06	1.04	1.00	1.05	1.03	1.02	1.04	1.02	1.01	1.03	1.02	1.01	1.00
7	1.09	1.06	1.04	1.02	1.08	1.05	1.03	1.00	1.04	1.03	1.01	1.04	1.02	1.01	1.03	1.02	1.01	1.00
8	1.08	1.05	1.03	1.02	1.08	1.05	1.03	1.00	1.04	1.02	1.01	1.03	1.02	1.01	1.03	1.01	1.01	1.00
9	1.08	1.05	1.03	1.01	1.07	1.04	1.02	1.00	1.04	1.02	1.01	1.03	1.02	1.01	1.03	1.01	1.00	1.00
10	1.07	1.04	1.02	1.01	1.07	1.04	1.02	1.00	1.03	1.02	1.01	1.03	1.02	1.01	1.03	1.01	1.00	1.00

eW Reach Powercore gen2 2700 K 5° diffuser lens, half unit

Lumens	Efficacy
6,562	55.8

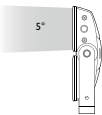

Polar Candela Distribution

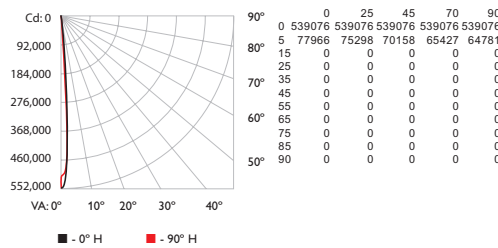

Illuminance at Distance

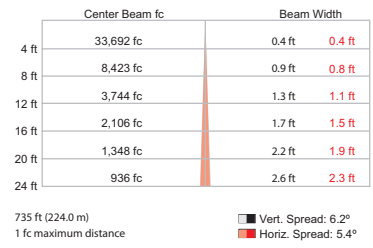

Zonal Lumen

Zone	Lumens	% Luminaire
0-30	6,825.3	100.0%
0-40	6,825.3	100.0%
0-60	6,825.3	100.0%
0-90	6,825.3	100.0%
60-90	0.0	0.0%
70-100	0.0	0.0%
90-120	0.0	0.0%
90-180	0.0	0.0%
0-180	6,825.3	100.0%

Coefficients Of Utilization - Zonal Cavity Method

RCC %:	80	70	50	30	10	0												
RW %:	70	50	30	0	50	30	20	10	0									
RCR:	0	1	2	3	4	5	6	7	8	9	10							
0	1.19	1.19	1.19	1.19	1.16	1.16	1.16	1.00	1.11	1.11	1.11	1.06	1.06	1.06	1.02	1.02	1.02	1.00
1	1.17	1.15	1.14	1.13	1.14	1.13	1.12	1.00	1.09	1.08	1.08	1.06	1.05	1.05	1.02	1.02	1.02	1.00
2	1.15	1.12	1.11	1.09	1.13	1.11	1.09	1.00	1.08	1.07	1.05	1.05	1.04	1.03	1.03	1.02	1.01	1.00
3	1.13	1.10	1.08	1.06	1.12	1.09	1.07	1.00	1.07	1.05	1.04	1.05	1.03	1.02	1.03	1.02	1.01	1.00
4	1.12	1.09	1.06	1.05	1.11	1.08	1.06	1.00	1.06	1.04	1.03	1.04	1.03	1.02	1.03	1.02	1.01	1.00
5	1.11	1.07	1.05	1.04	1.10	1.07	1.05	1.00	1.05	1.04	1.02	1.04	1.03	1.02	1.03	1.02	1.01	1.00
6	1.10	1.07	1.04	1.03	1.09	1.06	1.04	1.00	1.05	1.03	1.02	1.04	1.02	1.01	1.03	1.02	1.01	1.00
7	1.09	1.06	1.04	1.02	1.08	1.05	1.03	1.00	1.04	1.03	1.01	1.04	1.02	1.01	1.03	1.02	1.01	1.00
8	1.08	1.05	1.03	1.02	1.08	1.05	1.03	1.00	1.04	1.02	1.01	1.03	1.02	1.01	1.03	1.01	1.01	1.00
9	1.08	1.05	1.03	1.01	1.07	1.04	1.02	1.00	1.04	1.02	1.01	1.03	1.02	1.01	1.03	1.01	1.00	1.00
10	1.07	1.04	1.02	1.01	1.07	1.04	1.02	1.00	1.03	1.02	1.01	1.03	1.02	1.01	1.03	1.01	1.00	1.00

eW Reach Powercore gen2 2700 K
8° diffuser lens, half unit

Lumens	Efficacy
6,053	49.5

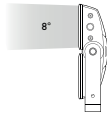

Polar Candela Distribution

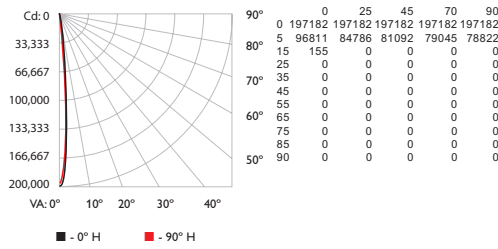

Illuminance at Distance

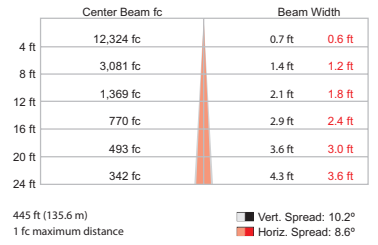

Zonal Lumen

Zone	Lumens	% Luminaire
0-30	6,052.6	100.0%
0-40	6,052.6	100.0%
0-60	6,052.6	100.0%
0-90	6,052.6	100.0%
60-90	0.0	0.0%
70-100	0.0	0.0%
90-120	0.0	0.0%
90-180	0.0	0.0%
0-180	6,052.6	100.0%

Coefficients Of Utilization - Zonal Cavity Method

RCC %:	80				70				50				30				10				0
	70	50	30	0	70	50	30	0	50	30	20	50	30	20	50	30	20	0			
RCR:	0	1.19	1.19	1.19	1.19	1.16	1.16	1.16	1.00	1.11	1.11	1.11	1.06	1.06	1.06	1.02	1.02	1.02	1.00		
1	1.17	1.15	1.14	1.13	1.14	1.13	1.12	1.10	1.08	1.08	1.07	1.06	1.05	1.04	1.04	1.02	1.02	1.01	1.00		
2	1.15	1.12	1.10	1.09	1.13	1.11	1.09	1.00	1.08	1.06	1.05	1.05	1.04	1.03	1.02	1.02	1.01	1.00	0.99		
3	1.13	1.10	1.08	1.06	1.11	1.09	1.07	1.00	1.06	1.05	1.03	1.04	1.03	1.02	1.02	1.01	1.00	0.99	0.99		
4	1.11	1.08	1.06	1.04	1.10	1.07	1.05	1.00	1.05	1.04	1.02	1.04	1.02	1.01	1.02	1.01	1.00	0.99	0.99		
5	1.10	1.07	1.04	1.03	1.09	1.06	1.04	0.99	1.05	1.03	1.01	1.03	1.02	1.01	1.02	1.01	1.00	0.99	0.99		
6	1.09	1.06	1.03	1.02	1.08	1.05	1.03	0.99	1.04	1.02	1.01	1.02	1.01	1.00	1.02	1.01	1.00	0.99	0.99		
7	1.08	1.05	1.02	1.01	1.07	1.04	1.02	0.99	1.03	1.02	1.00	1.02	1.01	1.00	1.02	1.00	0.99	0.99	0.99		
8	1.07	1.04	1.02	1.01	1.07	1.04	1.02	0.99	1.03	1.01	1.00	1.02	1.01	1.00	1.02	1.00	0.99	0.99	0.99		
9	1.07	1.03	1.01	1.00	1.06	1.03	1.01	0.99	1.02	1.01	1.00	1.02	1.00	0.99	1.01	1.00	0.99	0.99	0.99		
10	1.06	1.03	1.01	1.00	1.06	1.03	1.01	0.99	1.02	1.00	0.99	1.02	1.00	0.99	1.01	1.00	0.99	0.98	0.98		

eW Reach Powercore gen2 2700 K
13° diffuser lens, half unit

Lumens	Efficacy
6,047	49.4

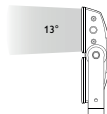

Polar Candela Distribution

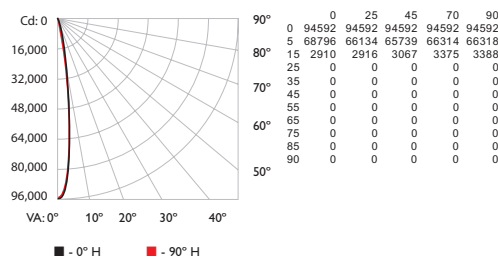

Illuminance at Distance

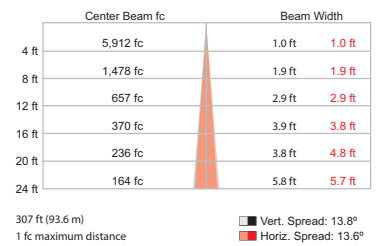

Zonal Lumen

Zone	Lumens	% Luminaire
0-30	6,047.5	100.0%
0-40	6,047.5	100.0%
0-60	6,047.5	100.0%
0-90	6,047.5	100.0%
60-90	0.0	0.0%
70-100	0.0	0.0%
90-120	0.0	0.0%
90-180	0.0	0.0%
0-180	6,047.5	100.0%

Coefficients Of Utilization - Zonal Cavity Method

RCC %:	80				70				50				30				10				0
	70	50	30	0	70	50	30	0	50	30	20	50	30	20	50	30	20	0			
RCR:	0	1.19	1.19	1.19	1.16	1.16	1.16	1.00	1.11	1.11	1.11	1.06	1.06	1.06	1.02	1.02	1.02	1.00			
1	1.16	1.15	1.13	1.12	1.14	1.13	1.11	0.99	1.09	1.08	1.07	1.05	1.04	1.04	1.02	1.01	1.01	0.99			
2	1.14	1.11	1.09	1.07	1.12	1.10	1.08	0.99	1.07	1.05	1.04	1.04	1.03	1.02	1.01	1.00	0.99	0.98			
3	1.12	1.09	1.06	1.04	1.10	1.07	1.05	0.98	1.05	1.03	1.02	1.03	1.01	1.00	1.01	1.00	0.99	0.98			
4	1.10	1.06	1.04	1.02	1.09	1.05	1.03	0.97	1.04	1.02	1.00	1.02	1.00	0.99	1.00	0.99	0.98	0.97			
5	1.08	1.04	1.02	1.00	1.07	1.04	1.01	0.97	1.02	1.00	0.99	1.01	0.99	0.98	1.00	0.98	0.97	0.96			
6	1.07	1.03	1.00	0.98	1.06	1.02	1.00	0.96	1.01	0.99	0.97	1.00	0.98	0.97	0.99	0.97	0.96	0.95			
7	1.06	1.02	0.99	0.97	1.05	1.01	0.99	0.95	1.00	0.98	0.96	0.99	0.97	0.96	0.98	0.97	0.96	0.95			
8	1.04	1.00	0.98	0.96	1.04	1.00	0.98	0.95	0.99	0.97	0.96	0.98	0.97	0.95	0.98	0.96	0.95	0.94			
9	1.03	0.99	0.97	0.95	1.03	0.99	0.97	0.94	0.98	0.96	0.95	0.98	0.96	0.95	0.97	0.95	0.94	0.94			
10	1.02	0.98	0.96	0.94	1.02	0.98	0.96	0.94	0.98	0.95	0.94	0.97	0.95	0.94	0.97	0.95	0.94	0.93			

eW Reach Powercore gen2 2700 K
23° diffuser lens, half unit

Lumens	Efficacy
5,901	48.2

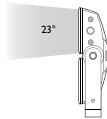

Polar Candela Distribution

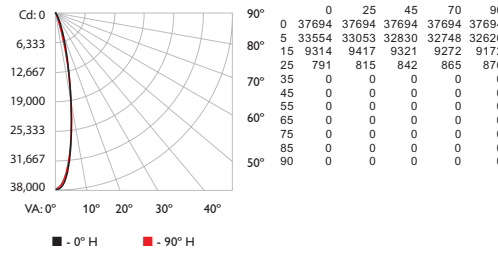

Illuminance at Distance

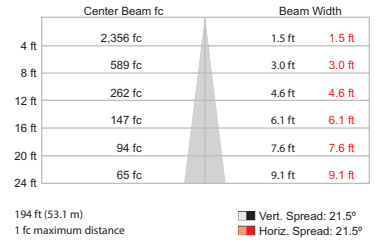

Zonal Lumen

Zone	Lumens	% Luminaire
0-30	5,898.3	100.0%
0-40	5,900.9	100.0%
0-60	5,900.9	100.0%
0-90	0.0	0.0%
70-100	0.0	0.0%
90-120	0.0	0.0%
90-180	0.0	0.0%
0-180	5,900.9	100.0%

Coefficients Of Utilization - Zonal Cavity Method

RCC %:	80				70				50				30				10				0
	70	50	30	0	70	50	30	0	50	30	20	50	30	20	50	30	20	0			
RCR:	0	1.19	1.19	1.19	1.16	1.16	1.16	1.00	1.11	1.11	1.11	1.06	1.06	1.06	1.02	1.02	1.02	1.00			
1	1.16	1.14	1.12	1.10	1.13	1.11	1.10	0.98	1.08	1.06	1.05	1.04	1.03	1.02	1.01	1.00	0.99	0.98			
2	1.12	1.09	1.06	1.04	1.10	1.07	1.05	0.96	1.04	1.03	1.01	1.02	1.00	0.99	0.97	0.96	0.95	0.95			
3	1.09	1.05	1.02	1.00	1.08	1.04	1.01	0.94	1.02	0.99	0.97	0.99	0.97	0.96	0.97	0.96	0.94	0.93			
4	1.07	1.02	0.99	0.96	1.05	1.01	0.98	0.92	0.99	0.96	0.94	0.97	0.95	0.93	0.96	0.94	0.92	0.91			
5	1.04	0.99	0.96	0.93	1.03	0.98	0.95	0.90	0.97	0.94	0.92	0.95	0.93	0.91	0.94	0.92	0.90	0.89			
6	1.02	0.96	0.93	0.90	1.01	0.96	0.92	0.88	0.95	0.92	0.89	0.93	0.91	0.89	0.92	0.90	0.88	0.87			
7	1.00	0.94	0.90	0.88	0.99	0.94	0.90	0.86	0.92	0.90	0.87	0.91	0.89	0.87	0.91	0.88	0.87	0.86			
8	0.97	0.92	0.88	0.86	0.97	0.91	0.88	0.85	0.91	0.88	0.85	0.90	0.87	0.85	0.89	0.87	0.85	0.84			
9	0.95	0.90	0.86	0.84	0.95	0.89	0.86	0.83	0.89	0.86	0.84	0.88	0.85	0.83	0.87	0.85	0.83	0.82			
10	0.94	0.88	0.85	0.82	0.93	0.88	0.84	0.82	0.87	0.84	0.82	0.86	0.84	0.82	0.86	0.83	0.82	0.81			

eW Reach Powercore gen2 2700 K
43° diffuser lens, half unit

Lumens	Efficacy
5,766	47.1

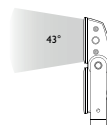

Polar Candela Distribution

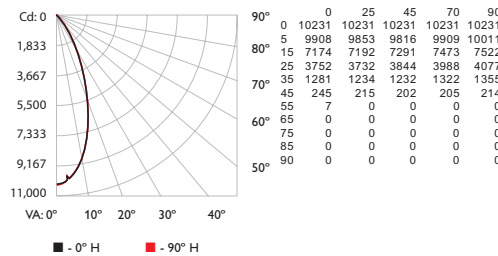

Illuminance at Distance

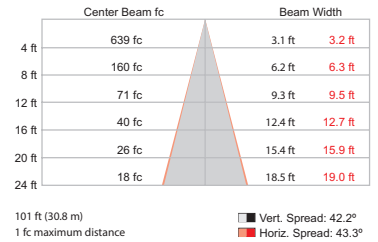

Zonal Lumen

Zone	Lumens	% Luminaire
0-30	4,692.5	81.4%
0-40	5,541.0	96.1%
0-60	5,766.0	100.0%
0-90	5,766.0	100.0%
60-90	0.0	0.0%
70-100	0.0	0.0%
90-120	0.0	0.0%
90-180	0.0	0.0%
0-180	5,766.0	100.0%

Coefficients Of Utilization - Zonal Cavity Method

RCC %:	80				70				50				30				10				0
	70	50	30	0	70	50	30	0	50	30	20	50	30	20	50	30	20	0			
RCR:	0	1.19	1.19	1.19	1.16	1.16	1.16	1.00	1.11	1.11	1.11	1.06	1.06	1.06	1.02	1.02	1.02	1.00			
1	1.14	1.12	1.09	1.07	1.12	1.09	1.07	0.95	1.05	1.04	1.02	1.02	1.00	0.99	0.98	0.97	0.96	0.95			
2	1.09	1.05	1.01	0.98	1.07	1.03	1.00	0.90	1.00	0.97	0.95	0.97	0.95	0.93	0.94	0.92	0.91	0.89			
3	1.04	0.98	0.94	0.90	1.02	0.97	0.93	0.85	0.95	0.91	0.88	0.92	0.89	0.87	0.90	0.88	0.86	0.84			
4	1.00	0.93	0.88	0.84	0.98	0.92	0.87	0.80	0.90	0.86	0.83	0.88	0.84	0.82	0.86	0.83	0.81	0.79			
5	0.95	0.88	0.83	0.79	0.94	0.87	0.82	0.76	0.85	0.81	0.78	0.84	0.80	0.77	0.82	0.79	0.76	0.75			
6	0.91	0.83	0.78	0.74	0.90	0.82	0.77	0.72	0.81	0.77	0.73	0.80	0.76	0.73	0.78	0.75	0.72	0.71			
7	0.87	0.79	0.74	0.70	0.86	0.78	0.73	0.68	0.77	0.73	0.69	0.76	0.72	0.69	0.75	0.71	0.69	0.67			
8	0.84	0.75	0.70	0.66	0.83	0.75	0.69	0.65	0.73	0.69	0.66	0.73	0.68	0.65	0.72	0.68	0.65	0.64			
9	0.80	0.72	0.66	0.63	0.79	0.71	0.66	0.62	0.70	0.66	0.62	0.69	0.65	0.62	0.69	0.65	0.62	0.61			
10	0.77	0.68	0.63	0.60	0.76	0.68	0.63	0.59	0.67	0.62	0.59	0.66	0.62	0.59	0.66	0.62	0.59	0.58			

eW Reach Powercore gen2 2700 K
63° diffuser lens, half unit

Lumens	Efficacy
5,736	46.9

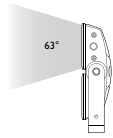

Polar Candela Distribution

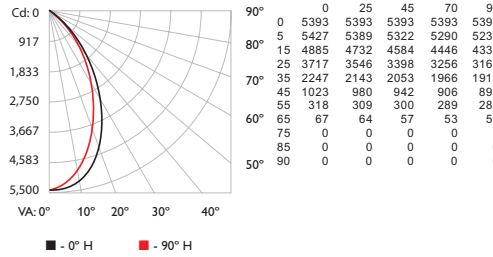

Illuminance at Distance

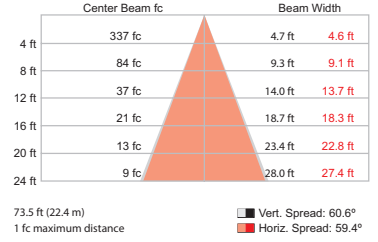

Zonal Lumen

Zone	Lumens	% Luminaire
0-30	3,322.5	57.9%
0-40	4,616.5	80.5%
0-60	5,663.1	98.7%
0-90	5,736.1	100.0%
60-90	73.1	1.3%
70-100	2.3	0.0%
90-120	0.0	0.0%
90-180	0.0	0.0%
0-180	5,736.1	100.0%

Coefficients Of Utilization - Zonal Cavity Method

Effective Floor Cavity Reflectance: 20%

RCC %:	80	70	50	30	10	0													
RW %:	70	50	30	0	50	30	20	50	30	20	0								
RCR:	0	1.19	1.19	1.19	1.19	1.16	1.16	1.16	1.00	1.11	1.11	1.11	1.06	1.06	1.06	1.02	1.02	1.02	1.00
1	1.13	1.10	1.07	1.05	1.10	1.08	1.05	0.93	1.04	1.02	1.00	1.00	0.98	0.97	0.96	0.95	0.94	0.92	
2	1.06	1.01	0.97	0.93	1.04	0.99	0.95	0.85	0.96	0.93	0.90	0.93	0.90	0.88	0.90	0.88	0.86	0.86	0.84
3	1.00	0.93	0.88	0.83	0.98	0.92	0.87	0.78	0.89	0.85	0.81	0.86	0.83	0.80	0.84	0.81	0.79	0.77	
4	0.94	0.86	0.80	0.75	0.92	0.85	0.79	0.72	0.83	0.78	0.74	0.80	0.76	0.73	0.79	0.75	0.72	0.70	
5	0.89	0.80	0.73	0.68	0.87	0.78	0.72	0.66	0.77	0.71	0.67	0.75	0.70	0.67	0.73	0.69	0.66	0.64	
6	0.84	0.74	0.67	0.62	0.82	0.73	0.67	0.61	0.71	0.66	0.62	0.70	0.65	0.61	0.69	0.64	0.61	0.59	
7	0.79	0.69	0.62	0.57	0.78	0.68	0.62	0.56	0.67	0.61	0.57	0.65	0.60	0.57	0.64	0.60	0.56	0.55	
8	0.75	0.64	0.58	0.53	0.73	0.64	0.57	0.52	0.62	0.57	0.53	0.61	0.56	0.53	0.60	0.56	0.52	0.51	
9	0.71	0.60	0.54	0.49	0.70	0.60	0.53	0.49	0.59	0.53	0.49	0.58	0.53	0.49	0.57	0.52	0.49	0.47	
10	0.67	0.57	0.50	0.46	0.66	0.56	0.50	0.45	0.55	0.50	0.46	0.54	0.49	0.46	0.54	0.49	0.45	0.44	

eW Reach Powercore gen2 2700 K
5° x 17° asymmetric lens, half unit

Lumens	Efficacy
6,065	49.6

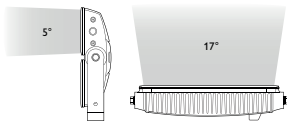

Polar Candela Distribution

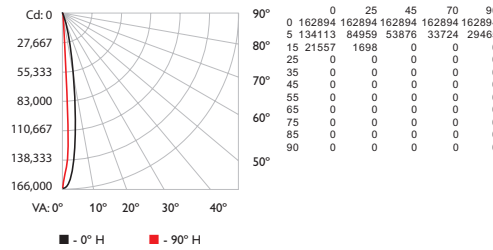

Illuminance at Distance

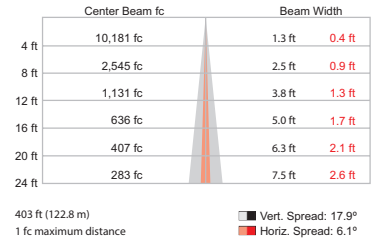

Zonal Lumen

Zone	Lumens	% Luminaire
0-30	6,064.9	100.0%
0-40	6,064.9	100.0%
0-60	6,064.9	100.0%
0-90	6,064.9	100.0%
60-90	0.0	0.0%
70-100	0.0	0.0%
90-120	0.0	0.0%
90-180	0.0	0.0%
0-180	6,064.9	100.0%

Coefficients Of Utilization - Zonal Cavity Method

Effective Floor Cavity Reflectance: 20%

RCC %:	80	70	50	30	10	0													
RW %:	70	50	30	0	50	30	20	50	30	20	0								
RCR:	0	1.19	1.19	1.19	1.16	1.16	1.16	1.00	1.11	1.11	1.11	1.06	1.06	1.06	1.02	1.02	1.02	1.00	
1	1.16	1.15	1.13	1.12	1.14	1.13	1.11	0.99	1.09	1.08	1.07	1.05	1.04	1.04	1.02	1.01	1.01	0.99	
2	1.14	1.11	1.09	1.07	1.12	1.10	1.08	0.99	1.07	1.05	1.04	1.04	1.03	1.02	1.01	1.01	1.00	0.99	
3	1.12	1.09	1.06	1.04	1.10	1.07	1.05	0.98	1.05	1.03	1.02	1.03	1.02	1.00	1.01	1.00	0.99	0.98	
4	1.10	1.07	1.04	1.02	1.09	1.06	1.03	0.98	1.04	1.02	1.00	1.02	1.00	0.99	1.00	0.98	0.98	0.97	
5	1.09	1.05	1.02	1.00	1.07	1.04	1.02	0.97	1.03	1.01	0.99	1.01	1.00	0.98	1.00	0.98	0.97	0.97	
6	1.07	1.03	1.01	0.99	1.06	1.03	1.00	0.96	1.02	0.99	0.98	1.00	0.99	0.97	0.99	0.98	0.97	0.96	
7	1.06	1.02	0.99	0.98	1.05	1.02	0.99	0.96	1.01	0.98	0.97	1.00	0.98	0.97	0.99	0.97	0.96	0.95	
8	1.05	1.01	0.98	0.97	1.04	1.00	0.98	0.95	1.00	0.98	0.96	0.99	0.97	0.96	0.98	0.97	0.96	0.95	
9	1.04	1.00	0.97	0.96	1.03	1.00	0.97	0.95	0.99	0.97	0.95	0.98	0.97	0.95	0.98	0.96	0.95	0.94	
10	1.03	0.99	0.97	0.95	1.02	0.99	0.97	0.94	0.98	0.96	0.95	0.98	0.96	0.95	0.97	0.96	0.94	0.94	

Photometrics

Photometric data is based on test results from an independent NIST traceable testing lab. IES data is available at www.philipscolorkinetics.com/support/ies.

eW Reach Powercore gen2 4000 K 5° native lens, full unit

Lumens	Efficacy
14,646	60.9



Polar Candela Distribution

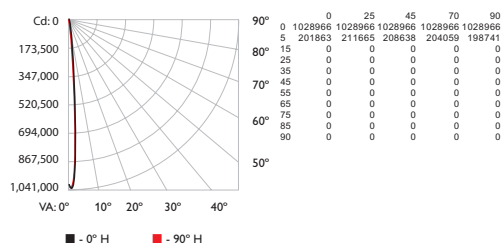

Illuminance at Distance

	Center Beam fc	Beam Width
4 ft	64,310 fc	0.4 ft 0.4 ft
8 ft	16,078 fc	0.9 ft 0.8 ft
12 ft	7,146 fc	1.4 ft 1.3 ft
16 ft	4,019 fc	1.9 ft 1.7 ft
20 ft	2,572 fc	2.3 ft 2.1 ft
24 ft	1,786 fc	2.8 ft 2.5 ft

1,015 ft (309.4 m)
1 fc maximum distance

Vert. Spread: 6.7°
Horiz. Spread: 6.1°

Zonal Lumen

Zone	Lumens	% Luminaire
0-30	15,025.9	100.0%
0-40	15,025.9	100.0%
0-60	15,025.9	100.0%
0-90	15,025.9	100.0%
60-90	0.0	0.0%
70-100	0.0	0.0%
90-120	0.0	0.0%
90-180	0.0	0.0%
0-180	15,025.9	100.0%

Coefficients Of Utilization - Zonal Cavity Method

RCC %:	80	70	50	30	10	0											
RW %:	70	50	30	0	50	30	20	50	30	20	50	30	20	0			
RCR:	0	1.19	1.19	1.19	1.16	1.16	1.00	1.11	1.11	1.11	1.06	1.06	1.06	1.02	1.02	1.02	1.00
1	1.17	1.15	1.14	1.13	1.14	1.13	1.12	1.09	1.08	1.08	1.06	1.05	1.05	1.02	1.02	1.02	1.00
2	1.15	1.12	1.11	1.09	1.13	1.11	1.09	1.08	1.07	1.05	1.05	1.04	1.03	1.03	1.02	1.01	1.00
3	1.13	1.10	1.08	1.06	1.12	1.09	1.07	1.07	1.05	1.04	1.05	1.03	1.02	1.03	1.02	1.01	1.00
4	1.12	1.09	1.06	1.05	1.11	1.08	1.06	1.06	1.04	1.03	1.04	1.03	1.02	1.03	1.02	1.01	1.00
5	1.11	1.07	1.05	1.04	1.10	1.07	1.05	1.05	1.04	1.02	1.04	1.03	1.02	1.03	1.02	1.01	1.00
6	1.10	1.07	1.04	1.03	1.09	1.06	1.04	1.00	1.05	1.03	1.02	1.04	1.02	1.01	1.03	1.02	1.01
7	1.09	1.06	1.04	1.02	1.08	1.05	1.03	1.00	1.04	1.03	1.01	1.04	1.02	1.01	1.03	1.02	1.01
8	1.08	1.05	1.03	1.02	1.08	1.05	1.03	1.00	1.04	1.02	1.01	1.03	1.02	1.01	1.03	1.01	1.00
9	1.08	1.05	1.03	1.01	1.07	1.04	1.02	1.00	1.04	1.02	1.01	1.03	1.02	1.01	1.03	1.01	1.00
10	1.07	1.04	1.02	1.01	1.07	1.04	1.02	1.00	1.03	1.02	1.01	1.03	1.02	1.01	1.03	1.01	1.00

eW Reach Powercore gen2 4000 K 5° diffuser lens, half unit

Lumens	Efficacy
7,441	59.8

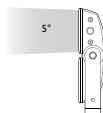

Polar Candela Distribution

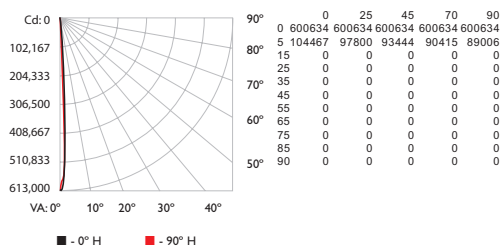

Illuminance at Distance

	Center Beam fc	Beam Width
4 ft	37,538 fc	0.4 ft 0.3 ft
8 ft	9,385 fc	0.9 ft 0.7 ft
12 ft	4,171 fc	1.3 ft 1.0 ft
16 ft	2,346 fc	1.8 ft 1.4 ft
20 ft	1,502 fc	2.2 ft 1.7 ft
24 ft	1,043 fc	2.7 ft 2.1 ft

775 ft (236.2 m)
1 fc maximum distance

Vert. Spread: 6.3°
Horiz. Spread: 5.0°

Zonal Lumen

Zone	Lumens	% Luminaire
0-30	7,548.6	100.0%
0-40	7,548.6	100.0%
0-60	7,548.6	100.0%
0-90	7,548.6	100.0%
60-90	0.0	0.0%
70-100	0.0	0.0%
90-120	0.0	0.0%
90-180	0.0	0.0%
0-180	7,548.6	100.0%

Coefficients Of Utilization - Zonal Cavity Method

RCC %:	80	70	50	30	10	0											
RW %:	70	50	30	0	50	30	20	50	30	20	50	30	20	0			
RCR:	0	1.19	1.19	1.19	1.16	1.16	1.00	1.11	1.11	1.11	1.06	1.06	1.06	1.02	1.02	1.02	1.00
1	1.17	1.15	1.14	1.13	1.14	1.13	1.12	1.09	1.08	1.08	1.06	1.05	1.05	1.02	1.02	1.02	1.00
2	1.15	1.12	1.11	1.09	1.13	1.11	1.09	1.08	1.07	1.05	1.05	1.04	1.03	1.03	1.02	1.01	1.00
3	1.13	1.10	1.08	1.06	1.12	1.09	1.07	1.00	1.07	1.05	1.04	1.05	1.03	1.02	1.03	1.02	1.01
4	1.12	1.09	1.06	1.05	1.11	1.08	1.06	1.00	1.06	1.04	1.03	1.04	1.03	1.02	1.03	1.02	1.01
5	1.11	1.07	1.05	1.04	1.10	1.07	1.05	1.00	1.05	1.04	1.02	1.04	1.03	1.02	1.03	1.02	1.01
6	1.10	1.07	1.04	1.03	1.09	1.06	1.04	1.00	1.05	1.03	1.02	1.04	1.02	1.01	1.03	1.02	1.01
7	1.09	1.06	1.04	1.02	1.08	1.05	1.03	1.00	1.04	1.03	1.01	1.04	1.02	1.01	1.03	1.02	1.01
8	1.08	1.05	1.03	1.02	1.08	1.05	1.03	1.00	1.04	1.02	1.01	1.03	1.02	1.01	1.03	1.01	1.00
9	1.08	1.05	1.03	1.01	1.07	1.04	1.02	1.00	1.04	1.02	1.01	1.03	1.02	1.01	1.03	1.01	1.00
10	1.07	1.04	1.02	1.01	1.07	1.04	1.02	1.00	1.03	1.02	1.01	1.03	1.02	1.01	1.03	1.01	1.00

eW Reach Powercore gen2 4000 K 8° diffuser lens, half unit

Lumens	Efficacy
6,729	53.3

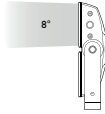

Polar Candela Distribution

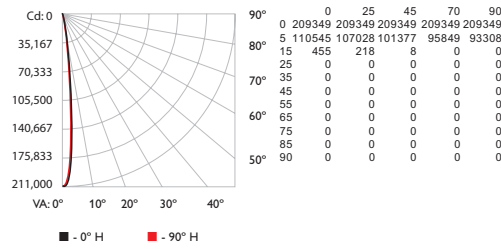

Illuminance at Distance

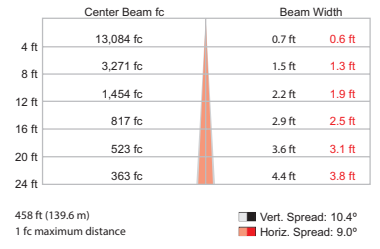

Zonal Lumen

Zone	Lumens	% Luminaire
0-30	6,728.7	100.0%
0-40	6,728.7	100.0%
0-60	6,728.7	100.0%
0-90	6,728.7	100.0%
60-90	0.0	0.0%
70-100	0.0	0.0%
90-120	0.0	0.0%
90-180	0.0	0.0%
0-180	6,728.7	100.0%

Coefficients Of Utilization - Zonal Cavity Method

RCC %:	80				70				50				30				10				0
	70	50	30	0	70	50	30	0	50	30	20	50	30	20	50	30	20	0			
RCR:																					
0	1.19	1.19	1.19	1.19	1.16	1.16	1.16	1.00	1.11	1.11	1.11	1.06	1.06	1.06	1.02	1.02	1.02	1.00	1.00		
1	1.17	1.15	1.14	1.13	1.14	1.13	1.12	1.00	1.09	1.08	1.07	1.05	1.05	1.04	1.02	1.02	1.01	1.00	1.00		
2	1.14	1.12	1.10	1.08	1.13	1.11	1.09	1.00	1.08	1.06	1.05	1.05	1.04	1.03	1.02	1.01	1.01	1.00	1.00		
3	1.13	1.10	1.08	1.06	1.11	1.09	1.07	1.00	1.06	1.05	1.03	1.04	1.03	1.02	1.02	1.01	1.00	0.99	0.99		
4	1.11	1.08	1.06	1.04	1.10	1.07	1.05	0.99	1.05	1.04	1.02	1.04	1.02	1.01	1.02	1.01	1.00	0.99	0.99		
5	1.10	1.07	1.04	1.02	1.09	1.06	1.04	0.99	1.04	1.03	1.01	1.03	1.02	1.00	1.02	1.01	1.00	0.99	0.99		
6	1.09	1.05	1.03	1.01	1.08	1.05	1.03	0.99	1.04	1.02	1.01	1.03	1.01	1.00	1.02	1.00	0.99	0.99	0.99		
7	1.08	1.05	1.02	1.01	1.07	1.04	1.02	0.99	1.03	1.01	1.00	1.02	1.01	1.00	1.02	1.00	0.99	0.99	0.99		
8	1.07	1.04	1.02	1.00	1.07	1.03	1.01	0.99	1.03	1.01	1.00	1.02	1.00	0.99	1.01	1.00	0.99	0.98	0.98		
9	1.07	1.03	1.01	1.00	1.06	1.03	1.01	0.99	1.02	1.00	0.99	1.02	1.00	0.99	1.01	1.00	0.99	0.98	0.98		
10	1.06	1.03	1.01	0.99	1.05	1.02	1.00	0.98	1.02	1.00	0.99	1.01	1.00	0.99	1.01	1.00	0.99	0.98	0.98		

eW Reach Powercore gen2 4000 K 13° diffuser lens, half unit

Lumens	Efficacy
6,680	52.9

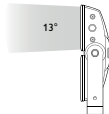

Polar Candela Distribution

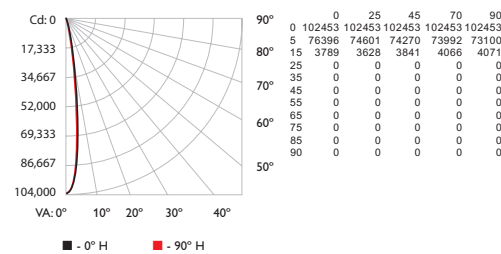

Illuminance at Distance

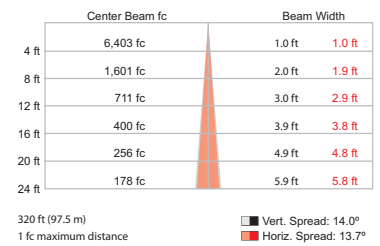

Zonal Lumen

Zone	Lumens	% Luminaire
0-30	6,680.2	100.0%
0-40	6,680.2	100.0%
0-60	6,680.2	100.0%
0-90	6,680.2	100.0%
60-90	0.0	0.0%
70-100	0.0	0.0%
90-120	0.0	0.0%
90-180	0.0	0.0%
0-180	6,680.2	100.0%

Coefficients Of Utilization - Zonal Cavity Method

RCC %:	80				70				50				30				10				0
	70	50	30	0	70	50	30	0	50	30	20	50	30	20	50	30	20	0			
RCR:																					
0	1.19	1.19	1.19	1.19	1.16	1.16	1.16	1.00	1.11	1.11	1.11	1.06	1.06	1.06	1.02	1.02	1.02	1.00	1.00		
1	1.16	1.15	1.13	1.12	1.14	1.13	1.11	0.99	1.09	1.08	1.07	1.05	1.04	1.04	1.02	1.01	1.01	1.00	0.99		
2	1.14	1.11	1.09	1.07	1.12	1.10	1.08	0.99	1.07	1.05	1.04	1.04	1.03	1.02	1.01	1.00	1.00	0.99	0.98		
3	1.12	1.08	1.06	1.04	1.10	1.07	1.05	0.98	1.05	1.03	1.02	1.03	1.01	1.00	1.01	1.00	0.99	0.97	0.97		
4	1.10	1.06	1.03	1.01	1.09	1.05	1.03	0.97	1.03	1.01	1.00	1.02	1.00	0.99	1.00	0.99	0.98	0.97	0.96		
5	1.08	1.04	1.02	1.00	1.07	1.04	1.01	0.96	1.02	1.00	0.98	1.01	0.99	0.98	0.99	0.98	0.97	0.96	0.96		
6	1.07	1.03	1.00	0.98	1.06	1.02	1.00	0.96	1.01	0.99	0.97	1.00	0.98	0.97	0.99	0.97	0.96	0.95	0.95		
7	1.05	1.01	0.99	0.97	1.05	1.01	0.98	0.95	1.00	0.98	0.96	0.99	0.97	0.96	0.98	0.97	0.95	0.95	0.95		
8	1.04	1.00	0.98	0.96	1.04	1.00	0.97	0.94	0.99	0.97	0.95	0.98	0.96	0.95	0.98	0.96	0.95	0.94	0.94		
9	1.03	0.99	0.97	0.95	1.03	0.99	0.96	0.94	0.98	0.96	0.94	0.97	0.95	0.94	0.97	0.95	0.94	0.93	0.93		
10	1.02	0.98	0.96	0.94	1.02	0.98	0.95	0.93	0.97	0.95	0.94	0.97	0.95	0.94	0.96	0.95	0.93	0.93	0.93		

eW Reach Powercore gen2 4000 K
23° diffuser lens, half unit

Lumens	Efficacy
6,446	51.1

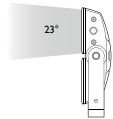

Polar Candela Distribution

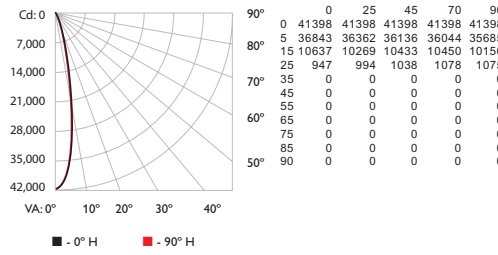

Illuminance at Distance

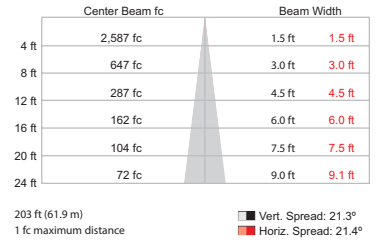

Zonal Lumen

Zone	Lumens	% Luminaire
0-30	6,441.9	99.9%
0-40	6,446.1	100.0%
0-60	6,446.1	100.0%
0-90	6,446.1	100.0%
60-90	0.0	0.0%
70-100	0.0	0.0%
90-120	0.0	0.0%
90-180	0.0	0.0%
0-180	6,446.1	100.0%

Coefficients Of Utilization - Zonal Cavity Method

RCC %:	80				70				50				30				10				0	
	70	50	30	0	70	50	30	0	50	30	20	50	30	20	50	30	20	0				
RCR:	0	1	2	3	4	5	6	7	8	9	10	11	12	13	14	15	16	17	18	19	20	
0	1.19	1.19	1.19	1.19	1.16	1.16	1.16	1.00	1.11	1.11	1.11	1.06	1.06	1.06	1.02	1.02	1.02	1.00	1.02	1.02	1.02	1.00
1	1.16	1.14	1.12	1.10	1.13	1.11	1.10	0.98	1.08	1.06	1.05	1.04	1.03	1.02	1.01	1.00	0.99	0.98	1.01	1.00	0.99	0.98
2	1.12	1.09	1.06	1.04	1.10	1.07	1.05	0.96	1.04	1.02	1.01	1.02	1.00	0.99	0.97	0.96	0.95	0.95	0.97	0.96	0.94	0.93
3	1.09	1.05	1.02	1.00	1.08	1.04	1.01	0.94	1.02	0.99	0.97	0.99	0.97	0.96	0.94	0.93	0.92	0.92	0.94	0.93	0.91	0.90
4	1.07	1.02	0.99	0.96	1.05	1.01	0.98	0.92	0.99	0.96	0.94	0.97	0.95	0.93	0.92	0.91	0.90	0.90	0.92	0.91	0.89	0.88
5	1.04	0.99	0.95	0.93	1.03	0.98	0.95	0.90	0.97	0.94	0.92	0.95	0.93	0.91	0.90	0.89	0.88	0.88	0.90	0.89	0.87	0.86
6	1.02	0.96	0.93	0.90	1.01	0.96	0.92	0.88	0.94	0.92	0.89	0.93	0.91	0.89	0.87	0.86	0.85	0.85	0.87	0.86	0.84	0.83
7	0.99	0.94	0.90	0.88	0.98	0.93	0.90	0.86	0.92	0.89	0.87	0.91	0.89	0.87	0.85	0.84	0.83	0.83	0.85	0.84	0.82	0.81
8	0.97	0.92	0.88	0.86	0.97	0.91	0.88	0.85	0.90	0.87	0.85	0.90	0.87	0.85	0.83	0.82	0.81	0.81	0.83	0.82	0.80	0.79
9	0.95	0.90	0.86	0.84	0.95	0.89	0.86	0.83	0.89	0.86	0.84	0.88	0.85	0.83	0.81	0.80	0.79	0.79	0.81	0.80	0.78	0.77
10	0.93	0.88	0.84	0.82	0.93	0.88	0.84	0.81	0.87	0.84	0.82	0.86	0.84	0.82	0.80	0.79	0.78	0.78	0.80	0.79	0.77	0.76

eW Reach Powercore gen2 4000 K
43° diffuser lens, half unit

Lumens	Efficacy
6,500	51.5

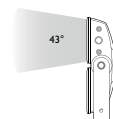

Polar Candela Distribution

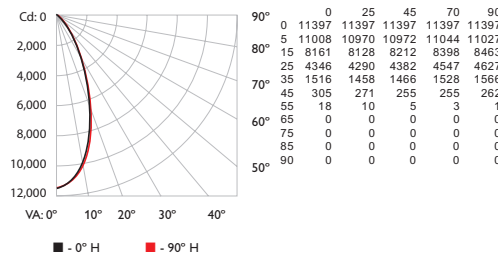

Illuminance at Distance

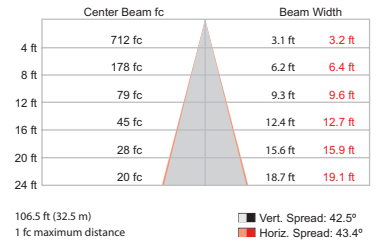

Zonal Lumen

Zone	Lumens	% Luminaire
0-30	5,258.5	80.9%
0-40	6,230.3	95.8%
0-60	6,500.3	100.0%
0-90	6,500.3	100.0%
60-90	0.0	0.0%
70-100	0.0	0.0%
90-120	0.0	0.0%
90-180	0.0	0.0%
0-180	6,500.3	100.0%

Coefficients Of Utilization - Zonal Cavity Method

RCC %:	80				70				50				30				10				0	
	70	50	30	0	70	50	30	0	50	30	20	50	30	20	50	30	20	0				
RCR:	0	1	2	3	4	5	6	7	8	9	10	11	12	13	14	15	16	17	18	19	20	
0	1.19	1.19	1.19	1.19	1.16	1.16	1.16	1.00	1.11	1.11	1.11	1.06	1.06	1.06	1.02	1.02	1.02	1.00	1.02	1.02	1.02	1.00
1	1.14	1.11	1.09	1.07	1.12	1.09	1.07	0.95	1.05	1.04	1.02	1.02	1.00	0.99	0.98	0.97	0.96	0.95	0.98	0.97	0.96	0.95
2	1.09	1.05	1.01	0.98	1.07	1.03	1.00	0.90	1.00	0.97	0.95	0.97	0.95	0.93	0.94	0.92	0.91	0.91	0.93	0.92	0.91	0.89
3	1.04	0.98	0.94	0.90	1.02	0.97	0.93	0.85	0.94	0.91	0.88	0.92	0.89	0.87	0.90	0.87	0.85	0.84	0.87	0.86	0.85	0.84
4	1.00	0.93	0.88	0.84	0.98	0.92	0.87	0.80	0.90	0.86	0.82	0.88	0.84	0.82	0.86	0.83	0.81	0.81	0.83	0.82	0.81	0.79
5	0.95	0.88	0.82	0.78	0.94	0.87	0.82	0.76	0.85	0.81	0.77	0.83	0.80	0.77	0.82	0.79	0.76	0.75	0.79	0.78	0.76	0.75
6	0.91	0.83	0.78	0.74	0.90	0.82	0.77	0.72	0.81	0.76	0.73	0.79	0.76	0.73	0.78	0.75	0.72	0.71	0.75	0.74	0.72	0.71
7	0.87	0.79	0.73	0.70	0.86	0.78	0.73	0.68	0.77	0.72	0.69	0.76	0.72	0.69	0.75	0.71	0.68	0.67	0.71	0.70	0.68	0.67
8	0.83	0.75	0.69	0.66	0.82	0.74	0.69	0.65	0.73	0.69	0.65	0.72	0.68	0.65	0.71	0.68	0.65	0.64	0.68	0.67	0.65	0.64
9	0.80	0.71	0.66	0.62	0.79	0.71	0.66	0.62	0.70	0.65	0.62	0.69	0.65	0.62	0.68	0.65	0.62	0.60	0.64	0.63	0.62	0.60
10	0.77	0.68	0.63	0.59	0.76	0.68	0.63	0.59	0.67	0.62	0.59	0.66	0.62	0.59	0.65	0.61	0.59	0.58	0.62	0.61	0.59	0.58

eW Reach Powercore gen2 4000 K 63° diffuser lens, half unit

Lumens	Efficacy
6,449	51.1

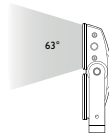

Polar Candela Distribution

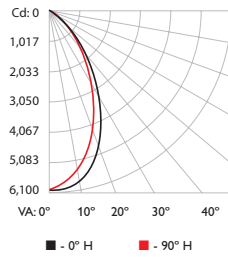

	0	25	45	70	90
90°	0	6009	6009	6009	6009
80°	5	6052	6009	5924	5880
	15	5459	5301	5134	4980
	25	4189	3992	3830	3669
70°	35	2554	2436	2324	2215
	45	1179	1130	1079	1029
	55	371	361	347	328
60°	65	79	77	68	63
	75	0	0	0	0
	85	0	0	0	0
50°	90	0	0	0	0

Illuminance at Distance

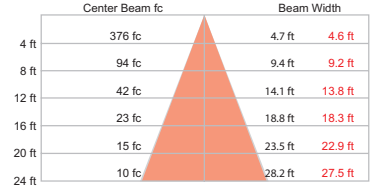

77.5 ft (23.6 m)
1 fc maximum distance
Vert. Spread: 60.8°
Horiz. Spread: 59.6°

Zonal Lumen

Zone	Lumens	% Luminaire
0-30	3,717.8	57.6%
0-40	5,175.5	80.3%
0-60	6,363.9	98.7%
0-90	6,449.1	100.0%
60-90	85.2	1.3%
70-100	3.0	0.0%
90-120	0.0	0.0%
90-180	0.0	0.0%
0-180	6,449.1	100.0%

Coefficients Of Utilization - Zonal Cavity Method

Effective Floor Cavity Reflectance: 20%

RCC %:	80	70	50	30	10	0													
RW %:	70	50	30	0	50	30	20	50	30	20	0								
RCR:	0	1.19	1.19	1.19	1.19	1.16	1.16	1.16	1.00	1.11	1.11	1.11	1.06	1.06	1.06	1.02	1.02	1.02	1.00
	1	1.13	1.10	1.07	1.05	1.10	1.08	1.05	0.93	1.04	1.02	1.00	1.00	0.98	0.97	0.96	0.95	0.94	0.92
	2	1.06	1.01	0.97	0.93	1.04	0.99	0.95	0.85	0.96	0.93	0.90	0.93	0.90	0.88	0.90	0.88	0.86	0.84
	3	1.00	0.93	0.87	0.83	0.98	0.92	0.86	0.78	0.89	0.85	0.81	0.86	0.83	0.80	0.84	0.81	0.78	0.77
	4	0.94	0.86	0.80	0.75	0.92	0.85	0.79	0.71	0.82	0.77	0.74	0.80	0.76	0.73	0.78	0.75	0.72	0.70
	5	0.89	0.79	0.73	0.68	0.87	0.78	0.72	0.66	0.77	0.71	0.67	0.75	0.70	0.67	0.73	0.69	0.66	0.64
	6	0.84	0.74	0.67	0.62	0.82	0.73	0.67	0.61	0.71	0.66	0.62	0.70	0.65	0.61	0.68	0.64	0.61	0.59
	7	0.79	0.69	0.62	0.57	0.78	0.68	0.62	0.56	0.67	0.61	0.57	0.65	0.60	0.57	0.64	0.60	0.56	0.55
	8	0.75	0.64	0.58	0.53	0.73	0.64	0.57	0.52	0.62	0.57	0.53	0.61	0.56	0.52	0.60	0.56	0.52	0.51
	9	0.71	0.60	0.54	0.49	0.69	0.60	0.53	0.48	0.59	0.53	0.49	0.58	0.52	0.49	0.57	0.52	0.49	0.47
	10	0.67	0.56	0.50	0.46	0.66	0.56	0.50	0.45	0.55	0.49	0.46	0.54	0.49	0.45	0.53	0.49	0.45	0.44

eW Reach Powercore gen2 4000 K 5° x 17° asymmetric lens, half unit

Lumens	Efficacy
6,065	48.1

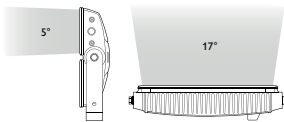

Polar Candela Distribution

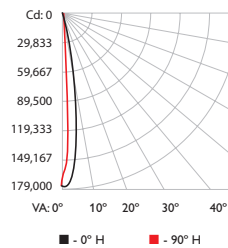

	0	25	45	70	90
90°	0	173815	173815	173815	173815
80°	5	147682	89521	58143	39043
	15	23392	2668	0	0
	25	0	0	0	0
70°	35	0	0	0	0
	45	0	0	0	0
	55	0	0	0	0
60°	65	0	0	0	0
	75	0	0	0	0
	85	0	0	0	0
50°	90	0	0	0	0

Illuminance at Distance

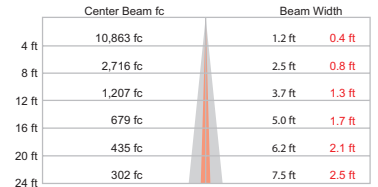

416 ft (126.8 m)
1 fc maximum distance
Vert. Spread: 17.7°
Horiz. Spread: 6.0°

Zonal Lumen

Zone	Lumens	% Luminaire
0-30	6,619.5	100.0%
0-40	6,619.5	100.0%
0-60	6,619.5	100.0%
0-90	6,619.5	100.0%
60-90	0.0	0.0%
70-100	0.0	0.0%
90-120	0.0	0.0%
90-180	0.0	0.0%
0-180	6,619.5	100.0%

Coefficients Of Utilization - Zonal Cavity Method

Effective Floor Cavity Reflectance: 20%

RCC %:	80	70	50	30	10	0													
RW %:	70	50	30	0	50	30	20	50	30	20	0								
RCR:	0	1.19	1.19	1.19	1.19	1.16	1.16	1.16	1.00	1.11	1.11	1.11	1.06	1.06	1.06	1.02	1.02	1.02	1.00
	1	1.16	1.15	1.13	1.12	1.14	1.13	1.11	0.99	1.09	1.08	1.07	1.05	1.04	1.04	1.02	1.01	1.01	0.99
	2	1.14	1.11	1.09	1.07	1.12	1.10	1.08	0.99	1.07	1.05	1.04	1.04	1.03	1.02	1.01	1.01	1.00	0.98
	3	1.12	1.09	1.06	1.04	1.10	1.07	1.05	0.98	1.05	1.03	1.02	1.03	1.02	1.00	1.01	1.00	0.99	0.98
	4	1.10	1.07	1.04	1.02	1.09	1.06	1.03	0.98	1.04	1.02	1.00	1.02	1.00	0.99	1.00	0.98	0.98	0.97
	5	1.09	1.05	1.02	1.00	1.07	1.04	1.01	0.97	1.02	1.00	0.99	1.01	0.99	0.98	1.00	0.98	0.97	0.96
	6	1.07	1.03	1.01	0.99	1.06	1.03	1.00	0.96	1.01	0.99	0.98	1.00	0.99	0.97	0.99	0.98	0.97	0.96
	7	1.06	1.02	0.99	0.97	1.05	1.01	0.99	0.96	1.00	0.98	0.97	1.00	0.98	0.96	0.99	0.97	0.96	0.95
	8	1.05	1.01	0.98	0.97	1.04	1.00	0.98	0.95	1.00	0.97	0.96	0.99	0.97	0.96	0.98	0.97	0.95	0.95
	9	1.04	1.00	0.97	0.96	1.03	0.99	0.97	0.95	0.99	0.97	0.95	0.98	0.96	0.95	0.98	0.96	0.95	0.94
	10	1.03	0.99	0.96	0.95	1.02	0.99	0.96	0.94	0.98	0.96	0.95	0.98	0.96	0.94	0.97	0.95	0.94	0.94

Specifications, UL/CE

Due to continuous improvements and innovations, specifications may change without notice.

Item	Specification	2700 K*	4000 K*
Output	Beam Angle	5° primary optic (no spread lens) 8°/13°/23°/43°/63°/5° x 17° (asymmetric) spread lenses	
	Lumens†	13,485 (no spread lens, full unit)	14,646 (no spread lens, full unit)
	Efficacy (lm/W)	56.7 (no spread lens, full unit)	60.9 (no spread lens, full unit)
	CRI	79.8 (no spread lens, full unit)	79.5 (no spread lens, full unit)
Electrical	Input Voltage	100 – 277 VAC, auto-switching, 50/60 Hz	
	Power Consumption	250 W maximum at full output, steady state	
	Power Factor	.989 @ 120 VAC	
Control		On/Off, digital dimming by 4 connector cable & DE Pro	
Physical	Dimensions (Height x Width x Depth)	522 x 733 x 122 mm (20.5 x 28.9 x 4.8 in)	
	Weight	34 kg (75 lb)	
	Effective Projected Area (EPA)	0.42 m ²	
	Housing	Die-cast aluminium, powder-coated finish	
	Mechanical Impact	IK07	
	Lens	Tempered glass	
	Fixture Connections	Integral male/female waterproof connector	
	Temperature Ranges	-40° – 50° C (-40° – 122° F) Operating -20° – 50° C (-4° – 122° F) Startup -40° – 80° C (-40° – 176° F) Storage	
Certification and Safety	Humidity	0 – 95%, non-condensing	
	Fixture Run Lengths	To calculate fixture run lengths and total power consumption for your specific installation, download the Configuration Calculator from www.philipscolorkinetics.com/support/install_tool/	
	Certification	UL/cUL, FCC Class A, CE, PSE	
Environment	Dry/Damp/Wet Location, IP66		

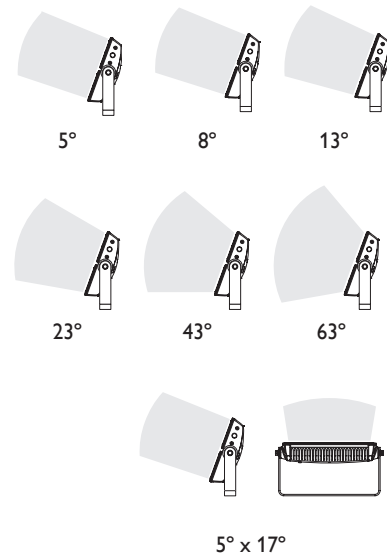

* Correlated color temperature (CCT) complies with ANSI C78.377-2008 for the chromaticity of solid state lighting products.



† Lumen measurement complies with IES LM-79-08 testing procedures.

Lumen Maintenance

Threshold§	Ambient Temperature	Reported¶	Calculated
L90	@ 25°C	42,300 hrs	84,100 hrs
	@ 50°C	42,300 hrs	48,300 hrs
L80	@ 25°C	42,300 hrs	>100,000 hrs
	@ 50°C	42,300 hrs	>100,000 hrs
L70	@ 25°C	42,300 hrs	>100,000 hrs
	@ 50°C	42,300 hrs	>100,000 hrs

§ L_{xx} = xx% lumen maintenance (when light output drops below xx% of initial output). All values are given at B50, or the median value where 50% of the LED population is better than the reported or calculated lumen maintenance measurement.

¶ Lumen maintenance figures are based on lifetime prediction graphs supplied by LED source manufacturers. Whenever possible, figures use measurements that comply with IES LM-80-08 testing procedures. In accordance with TM-21-11, reported values represent the interpolated value based on six times the LM-80-08 total test duration (in hours). Calculated values represent time durations that exceed six times the total test duration.

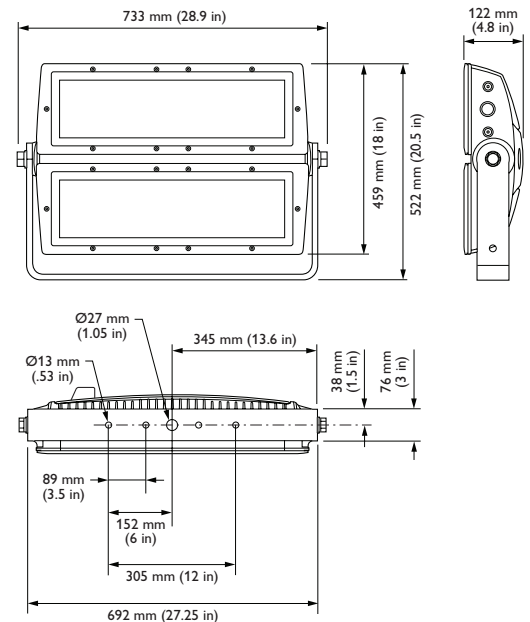

Specifications, CQC

Due to continuous improvements and innovations, specifications may change without notice.

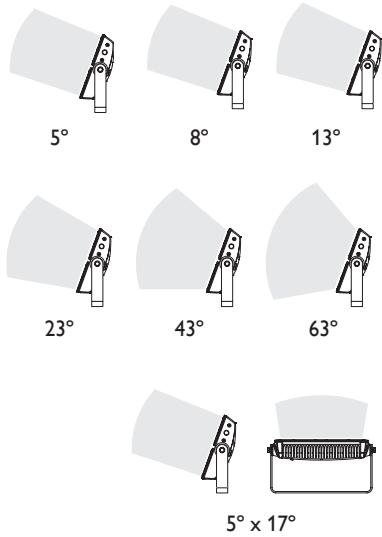

Item	Specification	2700 K*	4000 K*
Output	Beam Angle	5° primary optic (no spread lens) 8°/13°/23°/43°/63°/5° x 17° (asymmetric) spread lenses	
	Lumens†	13,485 (no spread lens, full unit)	14,646 (no spread lens, full unit)
	Efficacy (lm/W)	56.7 (no spread lens, full unit)	60.9 (no spread lens, full unit)
	CRI	79.8 (no spread lens, full unit)	79.5 (no spread lens, full unit)
Electrical	Input Voltage	100 – 240 VAC, auto-switching, 50/60 Hz	
	Power Consumption	250 W maximum at full output, steady state	
	Power Factor	.989 @ 120 VAC	
Control		On/Off, digital dimming by 4 connector cable & DE Pro	
Physical	Dimensions (Height x Width x Depth)	522 x 733 x 122 mm (20.5 x 28.9 x 4.8 in)	
	Weight	34 kg (75 lb)	
	Effective Projected Area (EPA)	0.42 m ²	
	Housing	Die-cast aluminium, powder-coated finish	
	Mechanical Impact	IK07	
	Lens	Tempered glass	
	Fixture Connections	Integral male/female waterproof connector, 1.8 m (6 ft) Leader Cable	
	Temperature Ranges	-40° – 50° C (-40° – 122° F) Operating -20° – 50° C (-4° – 122° F) Startup -40° – 80° C (-40° – 176° F) Storage	
	Humidity	0 – 95%, non-condensing	
	Fixture Run Lengths	To calculate fixture run lengths and total power consumption for your specific installation, download the Configuration Calculator from www.philipscolorkinetics.com/support/install_tool/	
Certification and Safety	Certification	FCC Class A, CE, PSE, CQC	
	Environment	Dry/Damp/Wet Location, IP66	

* Correlated color temperature (CCT) complies with ANSI C78.377-2008 for the chromaticity of solid state lighting products.



† Lumen measurement complies with IES LM-79-08 testing procedures.

Lumen Maintenance

Threshold§	Ambient Temperature	Reported ¶	Calculated ¶
L90	@ 25°C	42,300 hrs	84,100 hrs
	@ 50°C	42,300 hrs	48,300 hrs
L80	@ 25°C	42,300 hrs	>100,000 hrs
	@ 50°C	42,300 hrs	>100,000 hrs
L70	@ 25°C	42,300 hrs	>100,000 hrs
	@ 50°C	42,300 hrs	>100,000 hrs

§ L_{xx} = xx% lumen maintenance (when light output drops below xx% of initial output). All values are given at B50, or the median value where 50% of the LED population is better than the reported or calculated lumen maintenance measurement.

¶ Lumen maintenance figures are based on lifetime prediction graphs supplied by LED source manufacturers. Whenever possible, figures use measurements that comply with IES LM-80-08 testing procedures. In accordance with TM-21-11, reported values represent the interpolated value based on six times the LM-80-08 total test duration (in hours). Calculated values represent time durations that exceed six times the total test duration.

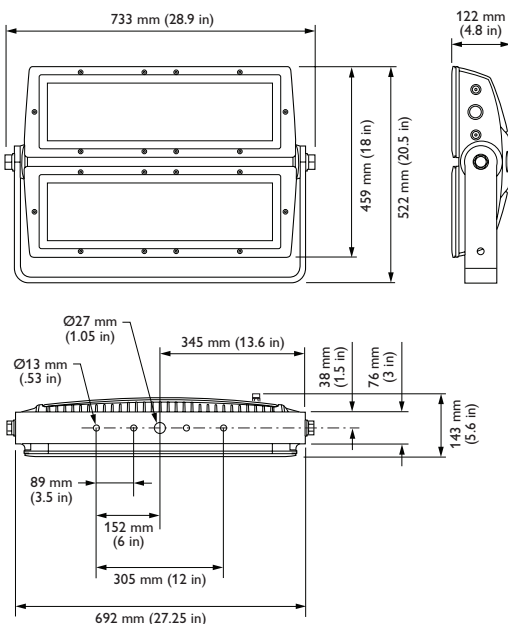

OPTIBIN[®] | POWERCORE[®]
CK TECHNOLOGY | CK TECHNOLOGY

Fixtures and Data Enabler Pro

eW Reach Powercore gen2 fixtures are part of a complete line-voltage system which includes fixtures and:

- One Leader Cable to connect each eW Reach Powercore gen2 fixture to a power source.
- 3-conductor copper wire to connect eW Reach Powercore gen2 fixtures in series or in parallel. Standard 12 AWG (2.05 mm) stranded wire is recommended.
- 4-conductor copper wire to connect eW Reach Powercore gen2 fixtures in series or in parallel, when digital dimming feature will be used, with a Philips Data Enabler Pro. 4-conductor wire is required for all connections downstream from the DE Pro.
- Philips Data Enabler Pro, when digital dimming feature will be used.

Fixtures

Item	Type	Item Number	Philips 12NC
eW Reach Powercore gen2 Leader cable(s) sold separately	UL/CE	2700 K	523-000093-12 912400133463
		4000 K	523-000093-15 912400133466
eW Reach Powercore gen2 Includes 6 ft (1.8 m) Leader Cable	CQC	2700 K	523-000044-76 912400133495
		4000 K	523-000044-79 912400133498

Use Item Number when ordering in North America.

Data Enabler

Item	Style	Item Number*	Philips 12NC
Data Enabler Pro	3/4 in / 1/2 in NPT (US trade size conduit)	106-000004-00	910503701210
	PG21/PG13 (metric size conduit)	106-000004-01	910503701211

Use Item Number when ordering in North America.

Accessories

All of the Philips Color Kinetics accessories are designed to provide customizable options for controlling and dispersing light as well as added protection.





Item	Type	Item Number	Philips 12NC
3 Conductor Replacement Leader Cable, 100–240 VAC;	6 ft (1.8 m) CE/PSE	108-000046-01	910503700622
3 Conductor Replacement Leader Cable, 100–240 VAC	6 ft (1.8 m) CQC	108-000046-02	910503704175
	10 ft (3.0 m) UL/cUL	108-000056-03	910503704071
3 Conductor Replacement Leader Cable, 100–277 VAC	CE/PSE	108-000056-04	910503704072
	50 ft (15.2 m) UL/cUL	108-000056-00	910503703138
	CE/PSE	108-000056-01	910503704069
4 Conductor Replacement Leader Cable (required to digitally dim unit, w/ DE Pro), 100–240 VAC	6 ft (1.8 m) CE/PSE	108-000043-03	910503700454
	10 ft (3.0 m) UL/cUL	108-000055-03	910503704066
4 Conductor Replacement Leader Cable (required to digitally dim unit, w/ DE Pro), 100–277 VAC	CE/PSE	108-000055-04	910503704067
	50 ft (15.2 m) UL/cUL	108-000055-00	910503703137
	CE/PSE	108-000055-01	910503704064

Use Item Number when ordering in North America.

Custom Configurations

In addition to the standard configurations listed here, custom configurations are also available with non-standard color temperatures or Royal Blue. Refer to the eW Reach Powercore gen2 Ordering Information sheet at www.philipscolorkinetics.com/ls/essentialwhite/ewreach/ for complete information.

Component	Available Non-Standard Options
Color Temperature	3000 K, 3500 K, 5000 K, 5500 K, 6000 K, 6500 K
Color	Royal Blue

Item	Item Number	Philips 12NC	
Louver <i>(Requires Trim Bezel)</i>	120-000187-02	912400133589	
Half Glare Shield <i>(Requires Trim Bezel)</i>	120-000187-01	912400133588	
Full Glare Shield <i>(Requires Trim Bezel)</i>	120-000187-00	912400133587	
Trim Bezel	120-000187-03	912400134263	
8° Spread Lens with Bezel	120-000068-17	912400133598	
13° Spread Lens with Bezel	120-000068-12	912400133593	
23° Spread Lens with Bezel	120-000068-13	912400133594	
43° Spread Lens with Bezel	120-000068-14	912400133595	
63° Spread Lens with Bezel	120-000068-15	912400133596	
5° X 17° Asymmetric Spread Lens with Bezel	120-000068-16	912400133597	

Installation

eW Reach Powercore gen2, a high-performance exterior architectural white floodlight with extended light projection, is designed to brilliantly illuminate prominent, signature façades. eW Reach Powercore has digital dimming capability and can be dimmed from 0% – 100% using DMX or Ethernet lighting controllers. Powercore technology integrates LED power and data management within the fixture, easing installation by eliminating the need for external power supplies. The dimming function requires a Philips Color Kinetics Data Enabler Pro (DE Pro) and 4-wire connector cables between the DE Pro and the fixtures.

 Refer to the *Data Enabler Pro Installation Instructions or Product Guide* for guidelines on configuring and positioning the Data Enabler Pro in relation to the controller.

Because each eW Reach Powercore gen2 fixture weighs 34 kg (75 lb), you may need two people to lift the fixture out of the box and position it in the mounting location. Optional accessory optics require the installation of both a spread lens and a bezel on each half of the fixture.

Owner/User Responsibilities

It is the responsibility of the contractor, installer, purchaser, owner, and user to install, maintain, and operate eW Reach Powercore gen2 fixtures in such a manner as to comply with all applicable codes, state and local laws, ordinances, and regulations. Consult with the appropriate electrical inspector to ensure compliance.

Installing in Wet or Damp Locations

When installing in wet or damp locations, you must seal all junction boxes with electronics-grade RTV silicone sealant so that water or moisture cannot enter or accumulate in wiring compartments, cables, fixtures, or other electrical parts. You must use suitable outdoor-rated junction boxes when installing in wet or damp locations. Additionally, you must use gaskets, clamps, and other parts required for installation to comply with all applicable local and national codes.

Prepare for the Installation

1. Determine the appropriate location of each Data Enabler Pro in relation to the fixtures, and of the fixtures in relation to each other. The Data Enabler Pro and first fixture must be separated by no more than the 3 m (10 ft) length of the Leader Cable.

eW Reach Powercore gen2 fixtures can be installed in series or in parallel (wired to a common junction box). The maximum number of fixtures each circuit (or DE Pro) can support depends on specific configuration details such as fixture spacing, circuit size, line voltage, and method of connection (in series or in parallel). For more information, and for help calculating the number of fixtures your specific installation can support, download the Configuration Calculator from www.philipscolorkinetics.com/support/install_tool/, or consult Application Engineering Services at support@colorkinetics.com.

2. Ensure that all additional parts and tools are available, including:
 - A 28 mm hex or adjustable wrench for adjusting the locking bolts on the fixture bracket
 - One electrical junction box per fixture, rated for your application. (Refer to the junction box manufacturer's literature for additional items required for mounting or sealing.)
 - A sufficient length of 3- or 4-conductor copper wire. We recommend 12 AWG (2.05 mm) stranded wire.
 - Conduit as required
 - Electronics-grade room temperature vulcanizing (RTV) silicone sealant

Start the Installation

1. If digital dimming is desired, install all Data Enabler Pro devices, including any interfaces with controllers. One Leader Cable is required to make connection to the fixture.
2. Verify that all additional supporting equipment (switches, controllers) is in place.
3. Ensure that all additional parts (optional mounting tracks, mounting hardware, terminators) and tools are available.
4. Unpack eW Reach Powercore gen2 fixtures. You may need two people to lift the fixture out of the box and position it in the mounting location.

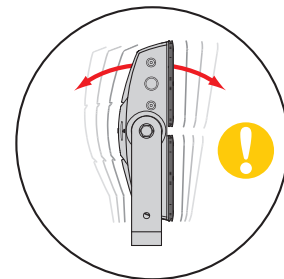
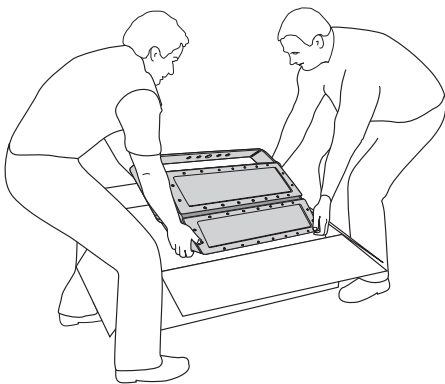

Do not rest eW Reach Powercore gen2 on its back, as doing so may damage the connector port. Be careful not to tip the fixture over during positioning.

Attach Accessory Lenses (Optional)

Accessories can be installed to change the beam angle or add extra glare control to the fixture in outdoor environments.

✳ For complete instructions on how to install the accessories, refer to the *Accessory Installation Instructions* at <http://www.colorkinetics.com/lis/accessories/Reach-Powercore/>

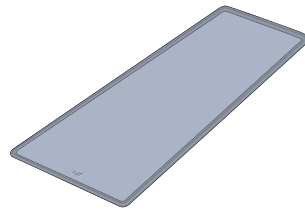

Spread Lens

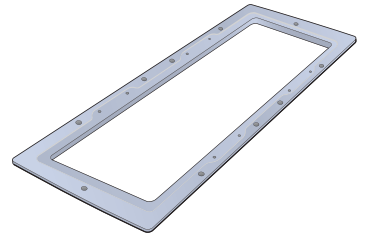

Trim Bezel

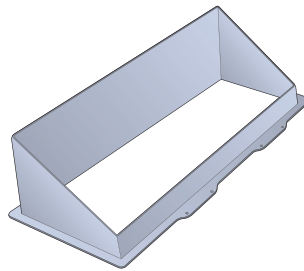

Half Glare Shield

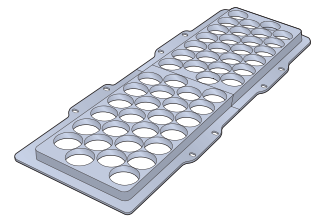

Louver

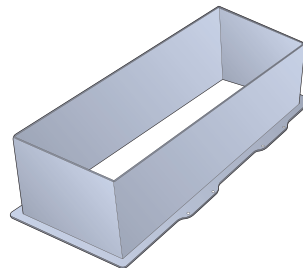

Full Glare Shield

Position and Mount Fixtures

Ensure that the fixture mounting locations and substrates are sufficiently sturdy to bear the weight of each eW Reach Powercore gen2 fixture. Pre-drill holes in the mounting substrate if necessary, making reference to the mounting bracket dimensions. Use at least two screws to secure each fixture, one on either side of the mounting bracket's central screw hole.

If mounting eW Reach Powercore gen2 on a lighting pole, make sure the pole can both support the total weight of the fixtures and withstand the maximum velocity winds to which it will be subjected. Each fixture weighs 34 kg (75 lb), and has an effective projected area (EPA) of 0.42 m².

1. Position each eW Reach Powercore gen2 fixture in its designated mounting location. Make sure the mounting area is clear of debris and other obstructions.

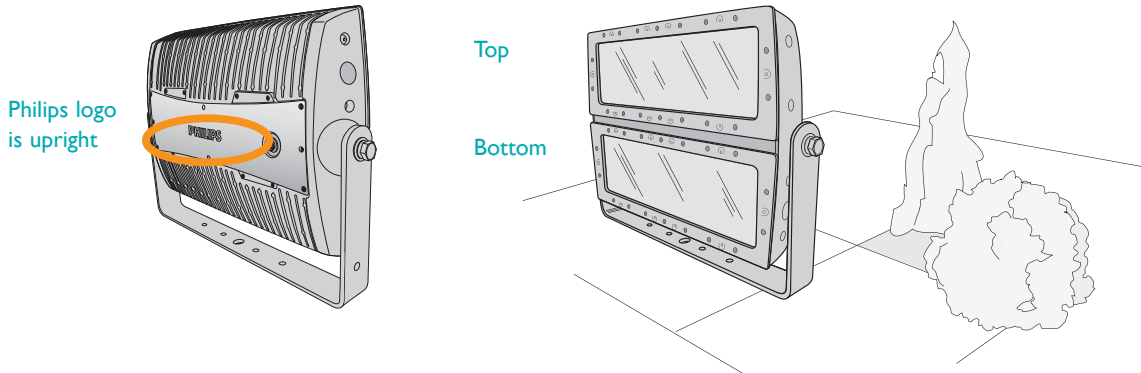

2. Loosen the locking bolts, using a 28 mm hex or adjustable wrench, and rotate the fixture to access the mounting bracket. Tilting the fixture 90° affords 184 mm (7.25 in) clearance.

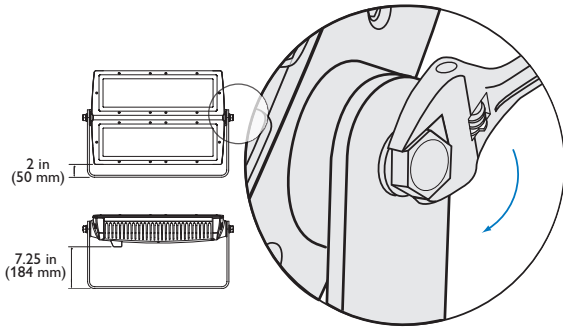

Mounting bracket dimensions for pre-drilling

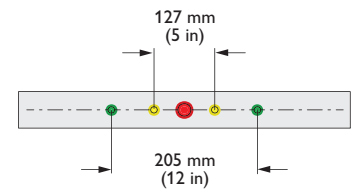

3. If mounting holes have been pre-drilled, align the mounting bracket's screw holes with the pre-drilled holes. Mount the fixture bracket using hardware appropriate for the mounting substrate. Use at least two screws to secure each fixture, one on either side of the mounting bracket's central screw hole.

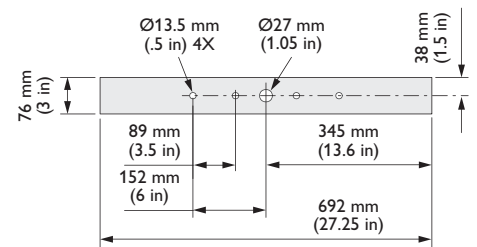
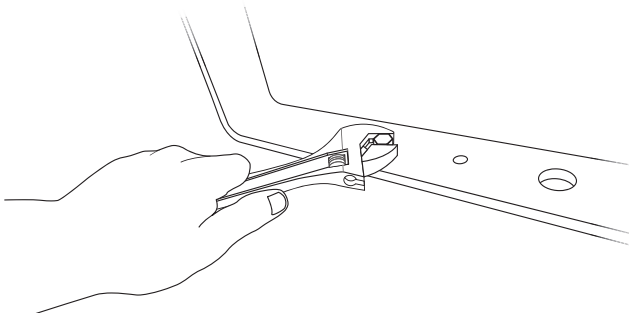

Connect Fixtures

Leader Cable connector dimensions

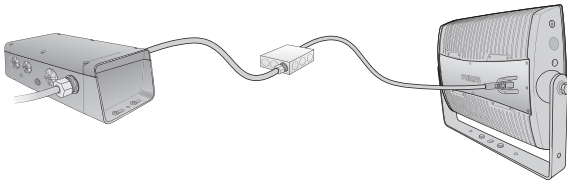
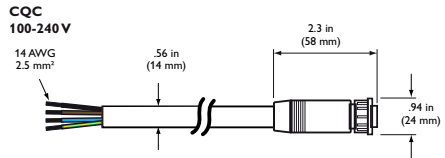
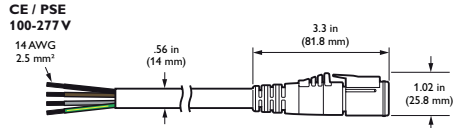
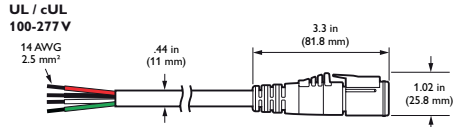

eW Reach Powercore gen2 fixtures can be installed in series or in parallel (wired to a common junction box). Ensure that all junction boxes are suitable for the environment and that all wiring between junction boxes complies with local codes.

Make sure the power is OFF before connecting eW Reach Powercore gen2 fixtures.

1. Install junction boxes. (Refer to the manufacturer's literature for additional items required for mounting or sealing.)
2. If installing fixtures in a series, pull 3-conductor copper wire between each junction box in the series. If installing fixtures in parallel, pull 3-conductor copper wire from a power source to a common junction box, and from the common junction box to each fixture's junction box.

If these fixtures are to use digital dimming and control features, there must be a Philips Color Kinetics Data Enabler Pro between the power mains and the first junction box. All cabling between the DE Pro and the downstream fixtures must be 4-conductor cables.

The maximum cable run from a Data Enabler Pro to any individual eW Reach Powercore gen2 fixture is 53 m (175 ft). When installing in parallel, the total cable length cannot exceed 122 m (400 ft).

3. If necessary, remove the connector cap from the port on the back of the eW Reach Powercore gen2 housing. Insert the Leader Cable into the port.

For installations with CQC-compatible (CE) cabling: Turn the Leader Cable's lock nut to the right until it locks into place.

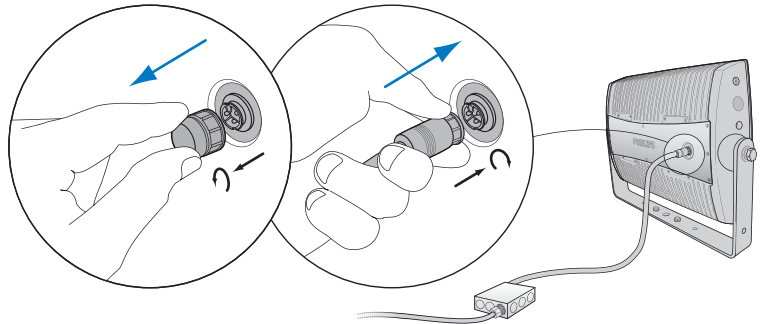

For installations with UL/cUL-compatible cabling: The Leader Cable snaps into place (it must be oriented to the only way it can fit) in the power port on the fixture.

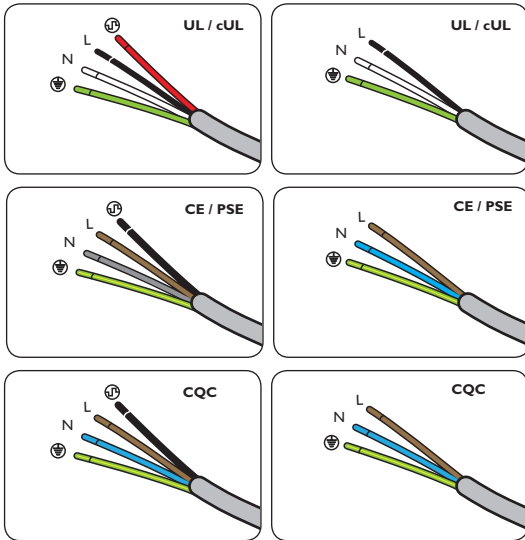
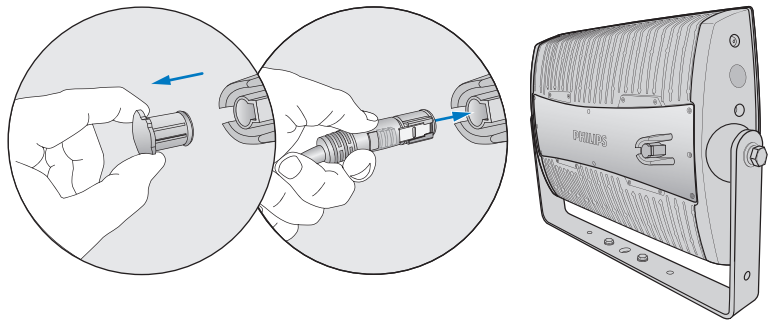

- Use wire nuts to connect line, neutral, and ground. If installing in series, connect the Leader Cable from each fixture to the fixture's junction box. If installing in parallel, connect the Leader Cable from each fixture to the lead wire from the power source in the common junction box.
- Tuck wire connections into the junction box.
- Seal all junction boxes and the DE Pro with electronics-grade RTV silicone sealant. Use gaskets, clamps, and other parts and fittings required to comply with local outdoor wiring codes.

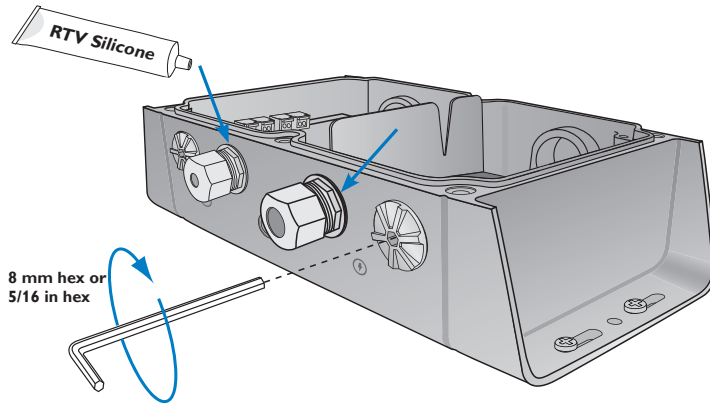

- Run the wiring from the first junction box in the series to the Data Enabler Pro, or, if installing in parallel, run the wiring from the common junction box to the Data Enabler Pro. Secure connections within the Data Enabler Pro housing.

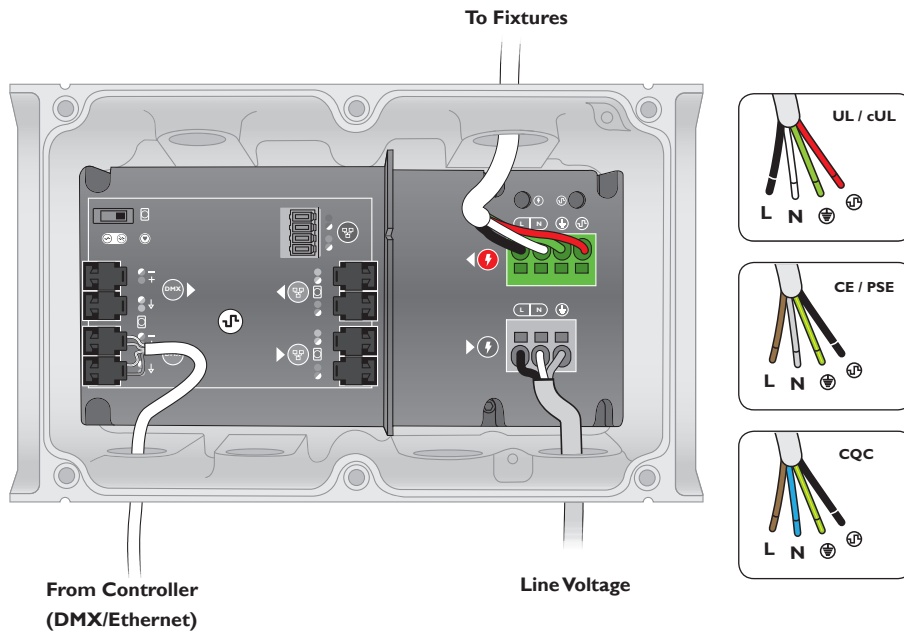

Connect to Power

You can connect the first junction box in a series, or a common junction box in a parallel installation, directly to a power source.

1. Run a sufficient length of 3-conductor wire from the first junction box in the series to the power source, or, if installing in parallel, run the wiring from the common junction box to the power source.
2. If installing in a wet or damp location, seal all junction boxes with electronics-grade RTV silicone sealant. Use gaskets, clamps, and other parts and fittings required to comply with local outdoor wiring codes.

⊗ Do not look directly into the fixture when aiming and locking.

⊗ For exterior applications with direct exposure to water, eW Reach Powercore gen2 fixtures should not be aimed directly upwards, as water may pool on the lens and affect beam quality. Instead, the fixture should be angled to allow for proper water drainage.

Aim and Lock the Fixtures

Make sure that the power is ON before aiming fixtures. Do not look directly into the fixture when aiming and locking.

1. Aim the fixtures by rotating each fixture to the correct angle.
2. Lock the fixtures by tightening the locking bolts using a 28 mm hex or adjustable wrench.

