



Date: _____ Type: _____

Firm Name: _____

Project: _____

eW Reach Powercore gen2

2700 K, 5° native (no spread lens), CQC

Premium long-throw exterior LED floodlight with solid white light

eW Reach Powercore gen2 combines all the benefits of LED-based lighting and control in an elegant fixture specifically designed for large-scale installations, such as skyscrapers, casinos, bridges, piers, public monuments, and themed attractions. With significantly more lumen output than any other competitive fixture and unprecedented light projection, this powerful fixture represents the next generation in exterior illumination. Fixtures are available in a warm 2700 K or a cool 4000 K. Custom configurations with custom channels of white or color LED sources are also available to support special applications.

- Integrates Powercore technology — Powercore technology rapidly, efficiently, and accurately controls power output to fixtures directly from line voltage.
- Unparalleled light output — Fixtures produce thousands of lumens and throw light hundreds of feet. eW Reach Powercore gen3 offers legitimate LED-based white light illumination of large-scale structures and objects.
- Versatile optics — Exchangeable spread lenses of 8°, 13°, 23°, 40°, 63°, and an asymmetric 5° x 17° support a variety of photometric distributions for a multitude of applications, including spotlighting, wall grazing, and asymmetric wall washing. Bezel and gasket are included with spread lenses for easy user installation.
- Unique split design — Spread lenses fit over each half of the fixture to support diffuser combinations. For instance, you could use one spread lens on the fixture's lower half to bathe a large façade with light at street level, and a different spread lens to project light hundreds of feet up the building's walls.

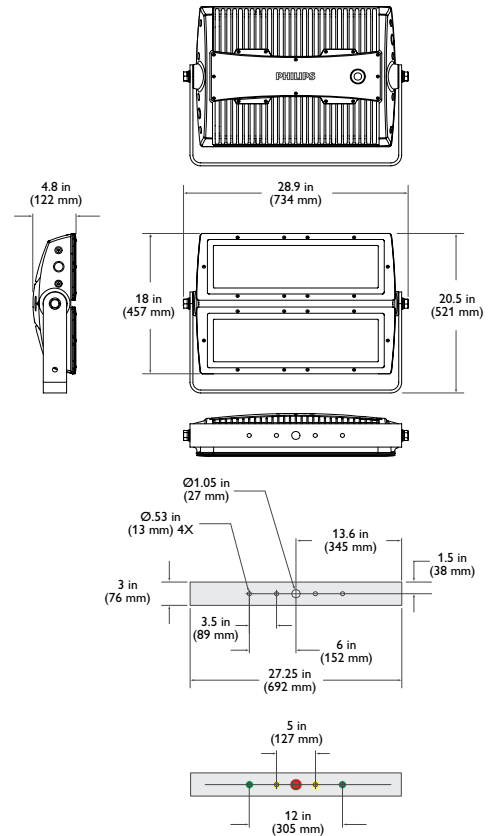

- Simple fixture positioning — Rugged, slim-profile mounting bracket allows simple positioning and fixture rotation through a full 360°. Side locking bolts reliably secure fixture with a standard wrench.
- Universal power input range — eW Reach Powercore gen2 accepts a universal power input range of 100 – 240 VAC, allowing consistent installation in any location around the world.

For detailed product information, please refer to the eW Reach Powercore gen2 Product Guide at www.philipscolorkinetics.com/ls/essentialwhite/ewreach/



Photometrics / eW Reach Powercore, 2700 K, 5° native (no spread lens)

Photometric data is based on test results from an independent NIST traceable testing lab. IES data is available at www.philipscolorkinetics.com/support/ies.

Full

Lumens	11,763
Efficacy	50.2 lm / W

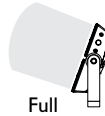

Full

Polar Candela Distribution

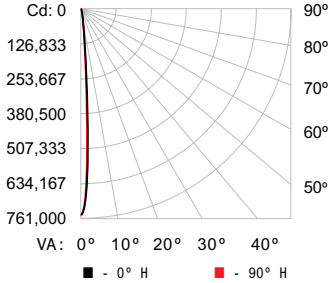

	0	25	45	70	90
0	906299	906299	906299	906299	906299
5	168650	146570	126250	103360	96224
15	1658	1598	1576	1532	1520
25	471	469	495	500	554
35	253	243	262	247	350
45	158	149	152	153	156
55	124	161	118	128	121
65	114	102	102	105	98
75	91	77	77	77	72
85	69	68	68	68	68
90	68	68	67	67	67

Illuminance at Distance

	Center Beam fc	Beam Width
4 ft	47,508 fc	0.4 ft 0.4 ft
8 ft	11,877 fc	0.9 ft 0.9 ft
12 ft	5,279 fc	1.3 ft 1.3 ft
16 ft	2,969 fc	1.7 ft 1.7 ft
20 ft	1,900 fc	2.2 ft 2.1 ft
24 ft	1,320 fc	2.6 ft 2.6 ft

870 ft (265.2 m)
1 fc maximum distance
 Vert. Spread: 6.2°
 Horiz. Spread: 6.1°

Coefficients Of Utilization - Zonal Cavity Method

		Effective Floor Cavity Reflectance: 20%											
RCC %:		80		70		50		30		10		0	
RW %:	RCR:	70	50	30	0	70	50	30	0	70	50	30	0
0	0	119	119	119	119	116	116	116	100	111	111	111	100
1	1	116	114	113	111	114	112	111	99	108	107	106	100
2	2	113	110	108	106	111	109	107	98	106	104	103	101
3	3	111	108	105	103	109	106	104	97	104	102	100	99
4	4	109	105	102	100	108	104	102	96	103	100	99	101
5	5	108	104	101	99	106	103	100	96	101	99	97	100
6	6	106	102	99	97	105	101	99	95	100	98	96	99
7	7	105	101	98	96	104	100	98	95	99	97	96	98
8	8	104	100	97	95	103	99	97	94	99	97	95	98
9	9	103	99	97	95	102	99	96	94	98	96	94	97
10	10	102	98	96	94	102	98	96	94	97	95	94	96

Zonal Lumen

Zone	Lumens	% Fixture
0 - 60	11,542.6	98.1 %
60 - 90	220.1	1.9 %
0 - 90	11,762.7	100.0 %

For lux multiply fc by 10.7

Half

Lumens	5,753
Efficacy	49.1 lm / W

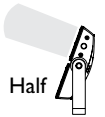

Half

Polar Candela Distribution

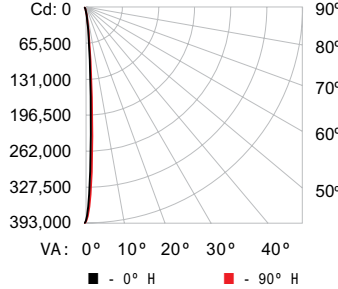

	0	25	45	70	90
0	392358	392358	392358	392358	392358
5	54390	58914	63073	62691	62217
15	705	717	743	768	794
25	212	210	223	228	249
35	111	108	115	110	154
45	68	64	65	66	69
55	52	66	49	54	52
65	47	42	42	44	41
75	37	32	31	31	30
85	28	28	28	28	28
90	28	28	28	28	28

Illuminance at Distance

	Center Beam fc	Beam Width
4 ft	24,522 fc	0.4 ft 0.4 ft
8 ft	6,131 fc	0.9 ft 0.8 ft
12 ft	2,725 fc	1.3 ft 1.2 ft
16 ft	1,533 fc	1.7 ft 1.6 ft
20 ft	981 fc	2.2 ft 2.0 ft
24 ft	681 fc	2.6 ft 2.4 ft

625 ft (190.5 m)
1 fc maximum distance
 Vert. Spread: 6.2°
 Horiz. Spread: 5.8°

Coefficients Of Utilization - Zonal Cavity Method

		Effective Floor Cavity Reflectance: 20%											
RCC %:		80		70		50		30		10		0	
RW %:	RCR:	70	50	30	0	70	50	30	0	70	50	30	0
0	0	119	119	119	119	116	116	116	100	111	111	111	100
1	1	116	114	113	111	114	112	111	99	108	107	106	100
2	2	113	110	108	106	111	109	107	98	106	104	103	101
3	3	111	108	105	103	109	106	104	97	104	102	100	99
4	4	109	105	102	100	108	104	102	96	103	100	99	101
5	5	108	104	101	99	106	103	100	95	101	99	97	100
6	6	106	102	99	97	105	101	99	95	100	98	96	99
7	7	105	101	98	96	104	100	98	95	99	97	96	98
8	8	104	100	97	95	103	99	97	94	99	96	95	98
9	9	103	99	96	95	102	99	96	94	98	96	94	97
10	10	102	98	96	94	102	98	96	93	97	95	94	96

Zonal Lumen

Zone	Lumens	% Fixture
0 - 60	5644.8	98.1 %
60 - 90	108.4	1.9 %
0 - 90	5753.2	100.0 %

For lux multiply fc by 10.7

Specifications

Due to continuous improvements and innovations, specifications may change without notice.

Item	Specification	2700 K* (Full Unit)	4000 K* (Full Unit)
Output	Lumens†	11,763	13,575
	Efficacy (lm / W)	50.2	56.2
	CRI	80	83
Electrical	Input Voltage	100 – 240 VAC, auto-switching, 50 / 60 Hz	
	Power Consumption	250 W maximum at full output, steady state	
	Power Factor	.989 @ 120 VAC	
Control		On / Off; digital dimming by 4 connector cable & DE Pro	
Physical	Dimensions (Height x Width x Depth)	20.5 x 28.9 x 4.8 in (521 x 734 x 122 mm)	
	Weight	75 lb (34 kg)	
	Effective Projected Area (EPA)	0.42 m ²	
	Housing	Die-cast aluminium, powder-coated finish	
	Lens	Tempered glass	
	Fixture Connections	6 ft (1.8 m) Leader Cable	
	Temperature Ranges	-40° – 122° F (-40° – 50° C) Operating -4° – 122° F (-20° – 50° C) Startup -40° – 176° F (-40° – 80° C) Storage	
	Fixture Run Lengths	To calculate fixture run lengths and total power consumption for your specific installation, download the Configuration Calculator from www.philipscolorkinetics.com/support/install_tool/	
Humidity	0 – 95%, non-condensing		
Certification and Safety	Certification	CQC, FCC Class A, CE, PSE	
	Environment	Dry / Damp / Wet Location, IP66	

* Correlated color temperature (CCT) complies with ANSI C78.377-2008 for the chromaticity of solid state lighting products.

† Lumen measurement complies with IES LM-79-08 testing procedures.



Lumen Maintenance

Threshold*	Ambient Temperature	Reported†	Calculated†
L90	@ 25°C	42,300 hrs	84,100 hrs
	@ 50°C	42,300 hrs	48,300 hrs
L80	@ 25°C	42,300 hrs	>100,000 hrs
	@ 50°C	42,300 hrs	>100,000 hrs
L70	@ 25°C	42,300 hrs	>100,000 hrs
	@ 50°C	42,300 hrs	>100,000 hrs

* L_{xx} = xx% lumen maintenance (when light output drops below xx% of initial output). All values are given at B50, or the median value where 50% of the LED population is better than the reported or calculated lumen maintenance measurement.

† Lumen maintenance figures are based on lifetime prediction graphs supplied by LED source manufacturers. Whenever possible, figures use measurements that comply with IES LM-80-08 testing procedures.

In accordance with TM-21-11, Reported values represent the interpolated value based on six times the LM-80-08 total test duration (in hours). Calculated values represent time durations that exceed six times the total test duration.

Fixtures and Accessories

Item	Type	Item Number	Philips 12NC
eW Reach Powercore gen2 <i>Includes 6 ft (1.8 m) leader cable</i>	2700 K	523-000044-51	912400130275
	4000 K	523-000044-53	912400130276
3 Conductor Replacement Leader Cable; 6 ft (1.8 m)	CE	108-000046-01	910503700622
4 Conductor Replacement Leader Cable (required to digitally dim unit, w/ DE Pro); 6 ft (1.8 m)	CE	108-000043-03	910503700454
Data Enabler Pro (required to digitally dim unit)	PG21 / PG13 (metric size conduit)	106-000004-01	910503701211
Spread Lens with bezel	8°	120-000068-05	910503700511
	13°	120-000068-00	910503700506
	23°	120-000068-01	910503700507
	40°	120-000068-02	910503700508
	63°	120-000068-03	910503700509
	Asymmetric (5° x 17°)	120-000068-04	910503700510

Use Item Number when ordering in North America.



Philips Color Kinetics
 3 Burlington Woods Drive
 Burlington, Massachusetts 01803 USA
 Tel 888.385.5742
 Tel 617.423.9999
 Fax 617.423.9998
www.philipscolorkinetics.com
 @ColorKinetics

Copyright © 2009 – 2014 Philips Solid-State Lighting Solutions, Inc. All rights reserved. Chromacore, Chromasic, CK, the CK logo, Color Kinetics, the Color Kinetics logo, ColorBlast, ColorBlaze, ColorBurst, eW Fuse, ColorGraze, ColorPlay, ColorReach, iW Reach, eW Reach, DIMand, EssentialWhite, eW, iColor, iColor Cove, IntelliWhite, iW, iPlayer, Optibin, and Powercore are either registered trademarks or trademarks of Philips Solid-State Lighting Solutions, Inc. in the United States and / or other countries. All other brand or product names are trademarks or registered trademarks of their respective owners. Due to continuous improvements and innovations, specifications may change without notice.

DAS-000031-01 R06 08-14