



Data Enabler Pro

Integrated data and power for intelligent LED lighting fixtures
using Powercore

PHILIPS

Data Enabler Pro

Integrated data and power for intelligent LED lighting fixtures using Powercore

Data Enabler Pro delivers integrated data and power to intelligent color and tunable white LED lighting fixtures employing Powercore® technology from Philips Color Kinetics. Data Enabler Pro integrates many of the features of the previous generation of Data Enablers, including Data Enabler DMX, Data Enabler Ethernet, Data Enabler EO, and iW® Data Enabler. Data Enabler Pro is the single solution for all intelligent Powercore-based installations, whether DMX or Ethernet, color or white, indoors or outdoors.

- Easy installation — Accessible, clearly labeled terminal block connectors for DMX, Ethernet, line voltage, and fixtures make installation easy. Tethered cover with captive screws ensures convenient removal and replacement.
- Supports fixtures employing Powercore technology — Powercore technology rapidly, efficiently, and accurately controls power output to LED lighting fixtures directly from line voltage. Philips Data Enabler Pro merges line voltage and control data and delivers them to Powercore fixtures over a single cable, dramatically simplifying installation and lowering total system cost.
- On-board diagnostics — On-board indicator LEDs provide visual feedback for normal operation, Ethernet connection detection, and Ethernet and DMX data transmission.
- Full support for DMX and Ethernet — Provides inputs and outputs for both DMX and Ethernet, allowing you to connect multiple Data Enabler Pro devices in series. Also provides an Ethernet output terminal for eW® Accent MX Powercore and iColor® Accent MX Powercore support.
- Outdoor-rated for use in damp and wet environments — Data Enabler Pro offers superior leakage protection in a cast aluminum, IP66-rated enclosure.
- Multiple conduit entries — Data Enabler Pro conduit entries accommodate NPT conduit in US trade sizes of 1/2 in and 3/4 in, or metric sizes of PG13.5 and PG21.
- Universal power input range — Data Enabler Pro automatically senses mains voltages ranging from 100 VAC to 277 VAC, and passes mains voltages through to all connected lights.



Designed for Maximum Energy Efficiency

Data Enabler Pro consumes just 20 W maximum. Optional power-saving modes automatically cut power to attached lights when lights are off for a configurable number of minutes.

Specifications

Due to continuous improvements and innovations, specifications may change without notice.

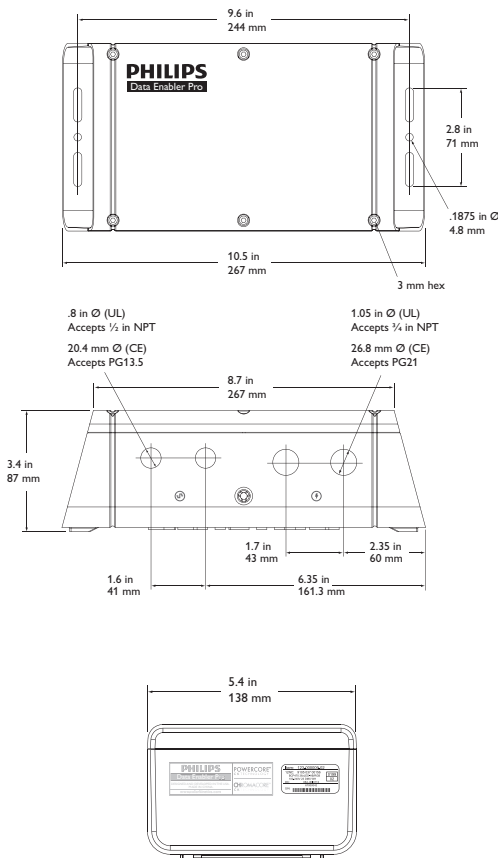

Item	Specification	Details
Electrical	Input Voltage	100 – 277 VAC*, auto-ranging, 50 / 60 Hz
	Maximum Input Current	16.5 A maximum
	Power Consumption	20 W maximum
	Load Current	16 A maximum
Connections	Power Input	3-wire PC terminal block connector†
	Power / Data Output	4-wire PC terminal block connector† 4-wire IDC terminal block connector (eW Accent MX Powercore and iColor Accent MX Powercore only)‡
	DMX Input / Output	Double-pair, double-entry IDC connectors‡
	Ethernet Input / Output	Double-pair, double-entry IDC connectors‡
Physical	Dimensions (Height x Width x Depth)	3.4 x 10.5 x 5.4 in (87 x 267 x 138 mm)
	Weight	5.4 lb (2.4 kg)
	Construction	Cast aluminum enclosure with slots for surface mounting
	Finish	Powder-coated gray matte
	Threaded Openings	3/4 in NPT for power / 1/2 in NPT for data (US trade sizes) PG21 for power / PG13.5 for data (metric sizes)
	Temperature Ranges	-40° – 122° F (-40° – 50° C) Operating -4° – 122° F (-20° – 50° C) Startup -40° – 176° F (-40° – 80° C) Storage
	Humidity	0 – 95%, non-condensing
	Cooling	Convection
	Heat Dissipation	20 W
	Data Input Source	Philips full range of controllers, third-party DMX controllers, or KiNET-compatible§ third-party Ethernet controllers
Certification and Safety	Certification	UL / cUL, FCC Class A, CE
	Environment	Dry / Damp / Wet Location, IP66

* Verify that the line voltage is appropriate for the lighting fixtures in your installation. See a specific fixture's documentation for supported line voltages.



† PC terminal block connectors accept recommended wire sizes from 8 – 18 AWG (8.37 – 0.823 mm²).

‡ IDC connectors accept wire sizes from 22 – 26 AWG (0.326 – 0.129 mm²).

§ KiNET™ is the Ethernet lighting protocol from Philips Color Kinetics.

Included in the box

Data Enabler Pro
8 mm hex wrench
3 mm hex wrench
Installation Instructions



Ordering Information

Item	Type	Item Number	Philips 12NC
Data Enabler Pro	3/4 in / 1/2 in NPT (US trade size conduit)	106-000004-00	910503701210
	PG21 / PG13 (metric size conduit)	106-000004-01	910503701211

Use Item Number when ordering in North America.

Installation

Data Enabler Pro integrates data and power transmission for all intelligent color and tunable white LED lighting fixtures employing Powercore technology from Philips Color Kinetics. Installation specifics will vary depending on fixture types, controller, environment (dry or damp / wet), and network (DMX, Ethernet, or a combination).

Owner / User Responsibilities

It is the responsibility of the contractor, installer, purchaser, owner, and user to install, maintain, and operate Data Enabler Pro in such a manner as to comply with all applicable codes, state and local laws, ordinances, and regulations. Consult with the appropriate electrical inspector to ensure compliance.

 Refer to the Data Enabler Pro Installation Instructions for specific warning and caution statements.

Installing in Damp or Wet Locations

When installing in damp or wet locations, seal all junction boxes, power supplies, and other devices with electronics-grade RTV silicone sealant so that water or moisture cannot enter or accumulate in any wiring compartments, cables, fixtures, or other electrical parts. You must use suitable outdoor-rated junction boxes when installing in wet or damp locations. Additionally, you must use gaskets, clamps, and other parts required for installation to comply with all applicable local and national codes.

Plan the Installation

To streamline installation and ensure accurate configuration, start with a layout or a lighting design plan that shows the physical layout of the installation and identifies the locations of all lighting fixtures, Data Enabler Pro devices, controllers, switches, and cables.

DMX and Ethernet Configurations

Data Enabler Pro can be used in either DMX or Ethernet networks. DMX is appropriate for relatively simple installations, or for installations in which groups of lights operate in unison — for example, for accent lighting, perimeter lighting, or cove lighting applications.

Typical DMX installations with intelligent LED lighting fixtures from Philips Color Kinetics use a controller such as iPlayer® 3, a Controller Keypad for turning the lighting system on and off and for triggering light shows, and one or more Data Enabler Pro devices. Data Enabler Pro devices can be connected in series to deliver DMX data from a single controller to all connected lights.

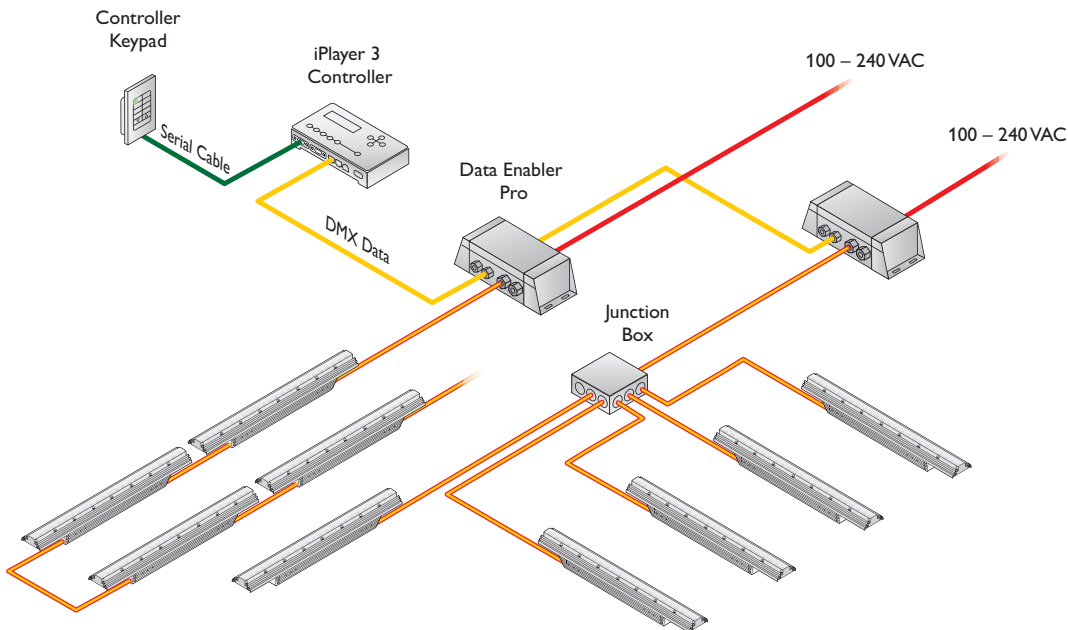

Because it is not subject to the DMX addressing limitations, Ethernet is the preferred environment for large-scale, color-changing light shows and video displays, both of which require large numbers of unique addresses.

Typical Ethernet installations with Philips Color Kinetics LED lighting fixtures use an Ethernet switch, an Ethernet controller such as Light System Manager or Video System Manager Pro, Ethernet Controller Keypads for push-button light show triggering, and one or more Data Enabler Pro devices. You can connect up to 15 Data Enabler Pro devices in series. For additional Data Enabler Pro devices in a network, use additional Ethernet switch ports.

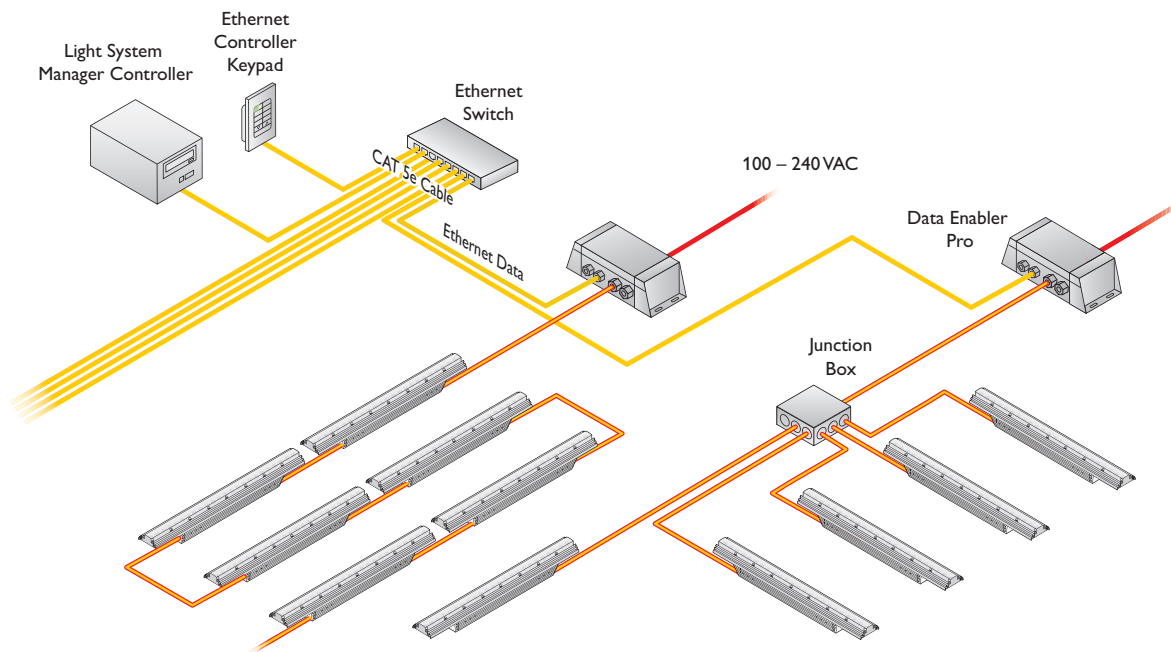

Electrical Configuration Guidelines

Linear Powercore fixtures, such as iColor Cove MX Powercore, iColor Accent Powercore, and iW Cove MX Powercore, are installed in series using the fixtures' end-to-end connectors or jumper cables. Multiple runs are typically installed to a common junction box. Powercore floodlights, wash lights, and spotlights, such as ColorReach Powercore, ColorBlast Powercore, and ColorBurst Powercore, can be installed in series (each wired to a separate junction box) or in parallel (wired to a common junction box).

The maximum number of fixtures each Data Enabler Pro can support depends on the fixture type and method of connection, as well as on additional configuration details such as fixture spacing, circuit size, wire gauge, and line voltage. As an example, the table to the left lists the maximum number of ColorBlast Powercore fixtures each Data Enabler Pro can support at various voltages, assuming a 20 A circuit and 5 ft (1.5 m) jumper cables between fixtures. Keep in mind that these figures, provided as a guideline, are accurate for the specified configuration only, and that changing the configuration can affect the number of fixtures per Data Enabler Pro.

Philips Color Kinetics offers a Configuration Calculator to help calculate the number of fixtures a specific installation can support. You can download the Configuration Calculator from www.colorkinetics.com/support/install_tool/. For further help, please consult Application Engineering Services at support@colorkinetics.com.

Data Enabler Pro must be installed in a location that allows air to move freely around the device. Startup and operating temperatures are rated to 122° F (50° C). Exceeding this temperature limit may cause device damage or failure.

ColorBlast Powercore fixture run length example

30 @ 110 VAC
36 @ 120 VAC
66 @ 220 VAC
72 @ 240 VAC

assuming fixtures installed on a 20 A circuit, using 5 ft (1.5 m) jumper cables

* Verify that the line voltage is appropriate for the lighting fixtures in your installation. See a specific fixture's documentation for supported line voltages.

Data Configuration Guidelines

In addition to maximum fixture run lengths determined by the electrical configuration, each Data Enabler Pro imposes maximum run lengths based on data integrity. To ensure data integrity, maximum individual run length should not exceed 175 feet (53.3 m), and the total cable length per Data Enabler Pro should not exceed 400 feet (122 m).

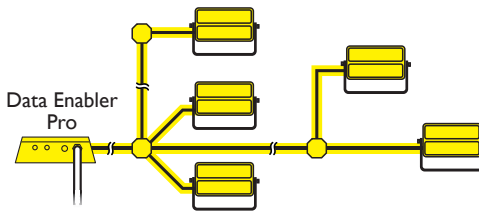
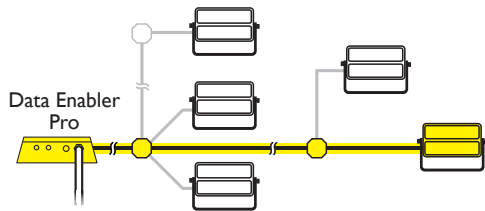
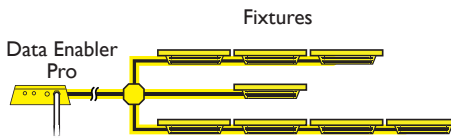
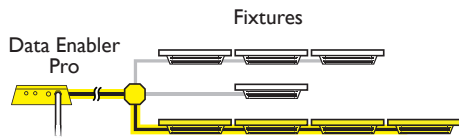

Data Integrity – maximum individual length 175 ft (53.3 m)

Data Integrity – total length 400 ft (122 m)

When selecting mounting locations for the Data Enabler Pro devices in your installation, keep cable and fixture run length maximums in mind:

- In Ethernet networks, maximum data cable lengths are 328 ft (100 m) between Ethernet devices without a repeater (for example, controller to switch, or switch to Data Enabler Pro).
- In DMX networks, maximum data run lengths are 1000 ft (305 m). The maximum number of Data Enabler Pro devices that can be connected in series is 32. We recommend using DMX repeaters for data run lengths that exceed the maximum length, as well as for runs of more than 32 Data Enabler Pro devices connected in series.

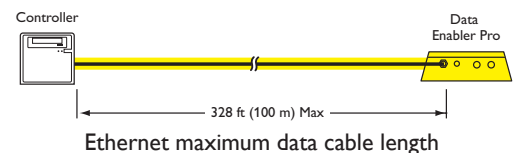

Ethernet maximum data cable length

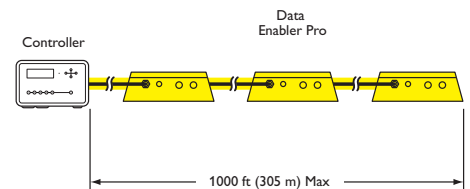

DMX maximum data run length

Assemble Additional Items

The following additional items are required to mount and connect Data Enabler Pro.

- 4 mounting screws suitable for the mounting surface
- For installations using US trade size conduit, 3/4 in NPT watertight conduit and fittings for power, and 1/2 in NPT watertight conduit and fittings for data, as required by local codes
- For installations using metric size conduit, PG21 watertight conduit and fittings for power, and PG13.5 watertight conduit and fittings for data, as required by local codes
- CAT 5e or better data cable, as required
- 4-conductor copper wire for fixture connections, as required. Standard 12 AWG (3.31 mm²) stranded wire is recommended.
- Electronics-grade RTV silicone for installations in damp and wet locations
- Screwdrivers, wire strippers, and other tools as needed

Inspect Data Enabler Pro and Accessories

Included in the box

Data Enabler Pro
8 mm hex wrench
3 mm hex wrench
Installation Instructions

Carefully inspect the box containing Data Enabler Pro and the contents for any damage that may have occurred in transit.

We recommend that you ensure your Data Enabler Pro devices are running the latest version of the firmware, and update the firmware if necessary, before positioning and mounting the devices. See pp. 20 – 23 of this guide for complete information.

Position and Mount Data Enabler Pro

Make sure the power is OFF before mounting and connecting Data Enabler Pro.

1. Each Data Enabler Pro device is identified by a unique serial number and IP address. The serial number and default IP addresses are located on a label inside the Data Enabler Pro housing. If your installation requires multiple Data Enabler Pro devices, record the serial numbers (DMX) or IP addresses (Ethernet) in a layout grid (typically a spreadsheet or list) for easy reference.
2. Assign each device to a position in the lighting design plan.
3. Position each Data Enabler Pro device in its designated mounting location. Make sure the mounting surface is flat, suitable for the mounting hardware, and clear of debris and other obstructions.

The overall dimensions of each Data Enabler Pro device are 10.5 in (267 mm) wide x 5.4 in (138 mm) deep x 3.4 in (87 mm) high. Make sure the mounting location allows enough space around the housing for air to move freely around the device. Be careful not to obstruct or submerge the vents on either side of the Data Enabler Pro housing.

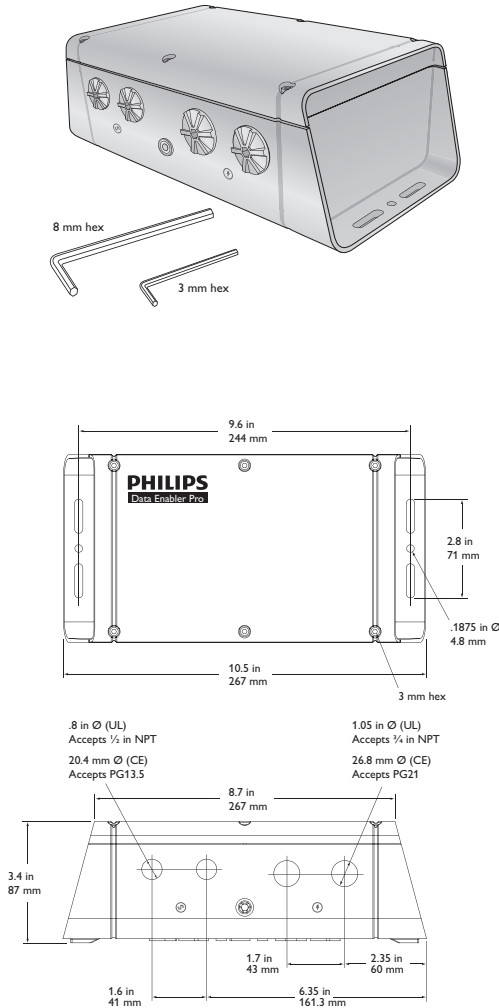

We recommend orienting Data Enabler Pro so that power and data cables enter the input side of the housing (the side with four threaded openings), and fixture cables exit the output side (the side with two threaded openings).

4. Use four suitable mounting screws to secure Data Enabler Pro to the mounting location.

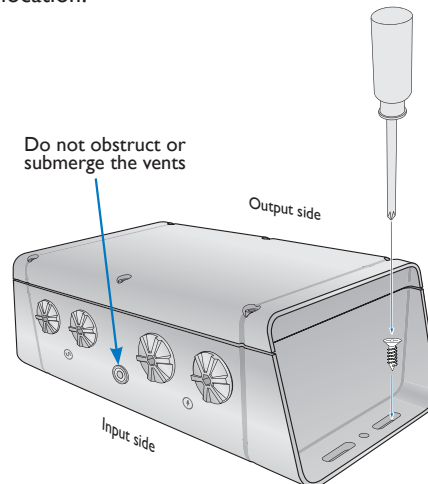

Prepare for Cable Connections

1. Using the included 3 mm hex wrench, loosen the housing cover's six captive screws to open the Data Enabler Pro housing.

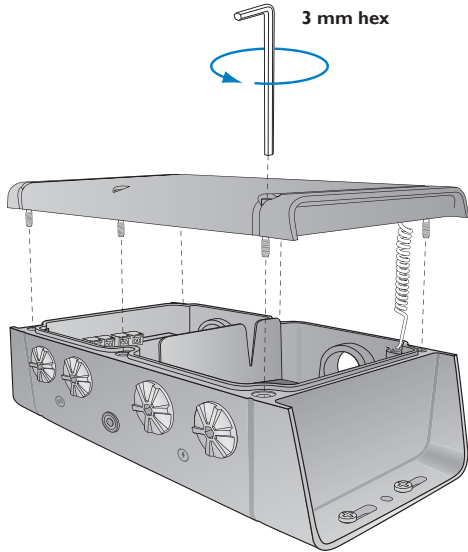

2. Identify which openings to use for power and data cables, and remove the seal plugs from the openings.
 - For installations using US trade size conduit, the larger openings accommodate 3/4 in NPT cable connectors for power, and the smaller openings accommodate 1/2 in NPT cable connectors for data.
 - For installations using metric size conduit, the larger openings accommodate PG21 cable connectors for power, and the smaller openings accommodate PG13.5 cable connectors for data.
3. Install and tighten cable connectors to manufacturer's specs. Do not overtighten.
4. Torque remaining seal plugs to approximately 19 in-lb (2.2 Nm).

 In wet or damp locations, use electronics-grade RTV silicone to seal all points of entry in all Data Enabler Pro devices and all connected junction boxes to prevent water infiltration.

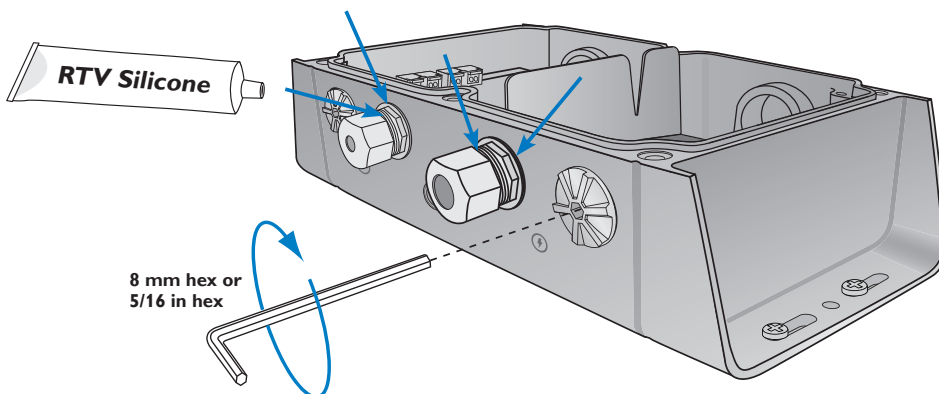

Make Data Input Connections

Data Enabler Pro has different connectors for DMX and Ethernet data inputs. Instead of RJ45 connectors, Data Enabler Pro uses double-pair, double-entry IDC connectors, which accept unstripped cable wire strands.

Philips Color Kinetics uses a DMX scheme that differs slightly from the popular DMX scheme maintained by the Entertainment Services and Technology Association (ESTA). You use the CK DMX scheme with Philips Color Kinetics DMX controllers, and the ESTA DMX scheme with many common third-party DMX controllers.

1. Run CAT 5e or better cable from the data output port of a Philips Color Kinetics DMX controller, such as iPlayer 3.
2. If necessary, cut the cable jacket to expose the wire pairs. Do not strip the wire pairs.
3. Locate the DMX input pivot connectors inside the Data Enabler Pro housing. Open both wire stuffers.
4. Insert the wires into the IDC connector's wire entry holes from right to left as follows:

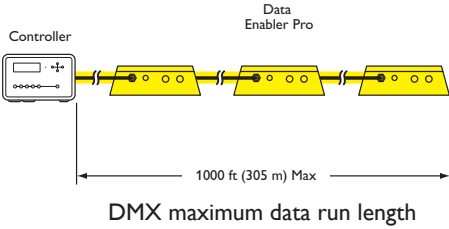
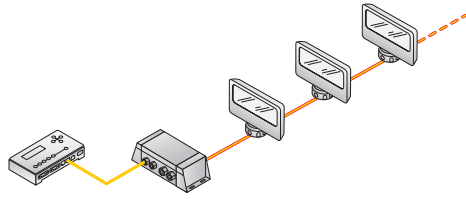

* IDC connectors accept wire sizes from 22 – 26 AWG (0.326 – 0.129 mm²).

CK RJ45 Pinouts

RJ45 Pin #	CK DMX Signal	Wire Color
1	DMX_DATA-	Orange / White
2	DMX_DATA+	Orange
3	GND	Green / White
6	GND	Green

ESTA RJ45 Pinouts

RJ45 Pin #	DMX512-A Signal	Wire Color
1	DMX_DATA+	Orange / White
2	DMX_DATA-	Orange
7	GND	Brown / White
8	GND	Brown

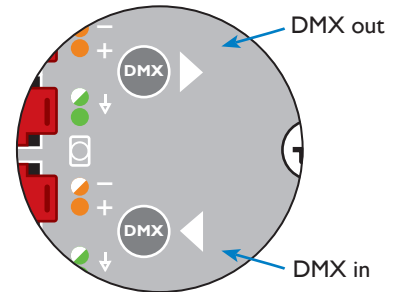
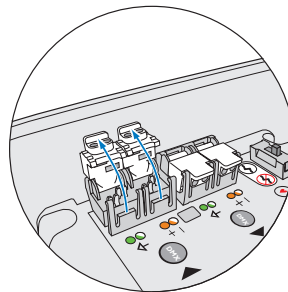
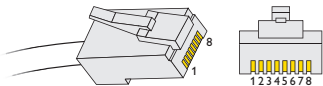

- For CK DMX, Orange / White, Orange, Green / White, and Green.
- For ESTA DMX, Orange / White, Orange, Brown / White, and Brown.

The unused wires should be capped and turned back.

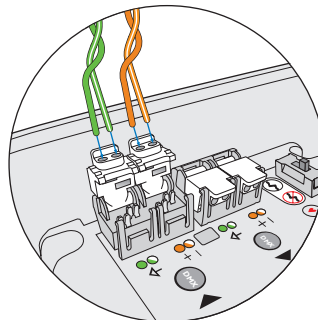

CK DMX wiring

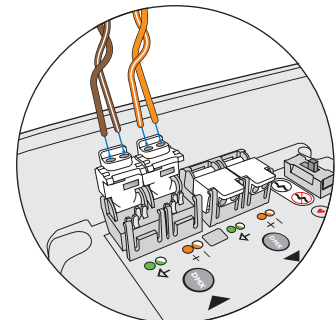

ESTA DMX wiring

5. While holding the wires firmly in place, push down on the wire stuffers until they click shut.

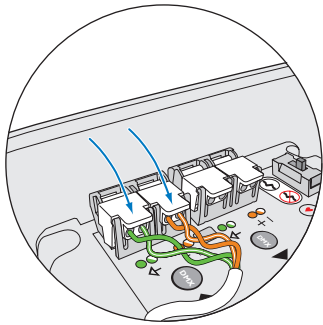

CK DMX wiring

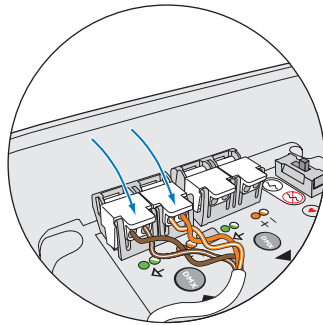

ESTA DMX wiring

6. Unless you're connecting additional devices in series, use the termination switch to terminate the series.

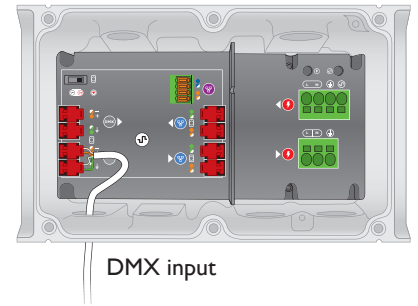
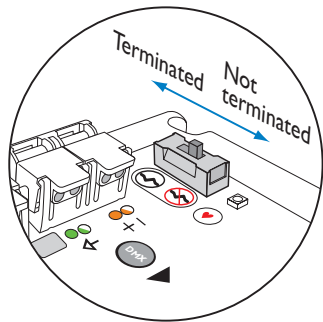

DMX input

Ethernet Data Input Connections

1. Run CAT 5e or better cable from the data output port of a Philips Color Kinetics Ethernet controller, such as Light System Manager or Video System Manager Pro.
2. If necessary, cut the cable jacket to expose the wire pairs. Do not strip the wire pairs.

The Brown, Brown / White, Blue, and Blue / White wires are not used and should be capped and turned back.

3. Locate the Ethernet input pivot connectors inside the Data Enabler Pro housing. Open both wire stuffers.

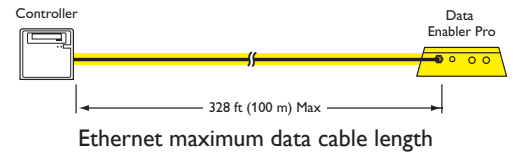
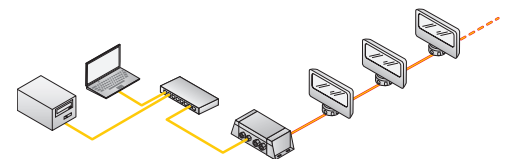

Ethernet maximum data cable length

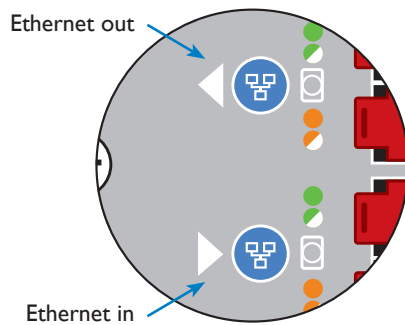
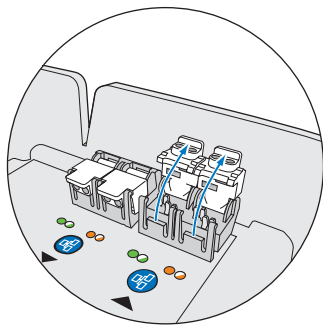

*** IDC connectors accept wire sizes from 22 – 26 AWG (0.326 – 0.129 mm²).**

Ethernet Pinouts

RJ45 Pin #	Ethernet Signal	Wire Color
1	RxD+	Orange / White
2	RxD-	Orange
3	TxD+	Green / White
6	TxD-	Green

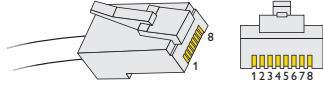

- From right to left, following the wire color codes printed on the data board, insert the Orange / White, Orange, Green / White, and Green wires into the pivot connector's wire entry holes.

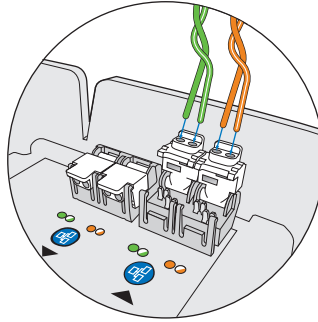

- While holding the wires firmly in place, push down on the wire stuffers until they click shut.

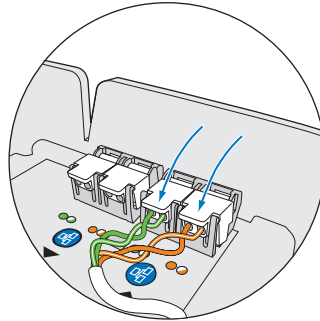
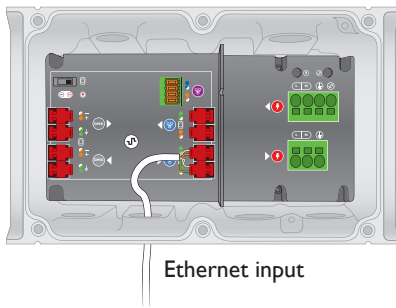

Connecting Data Enabler Pro Devices in Series (Optional)

Installations with large numbers of fixtures may require multiple Data Enabler Pro devices. Data Enabler Pro affords DMX and Ethernet output connectors, which you can use to connect two or more Data Enabler Pro devices in series.

Series Connection Using DMX

In DMX networks, you should use DMX repeaters for run lengths of over 1000 ft (325 m). Also use a DMX repeater for runs of more than 32 Data Enabler Pro devices connected in series.

1. Cut a sufficient length of CAT 5e or better cable to connect the first Data Enabler Pro device in a series with the next.
2. If necessary, cut both ends of the cable jacket to expose the wire pairs. Do not strip the wire pairs.

The Brown, Brown / White, Blue, and Blue / White wires are not used and should be capped and turned back.

3. Run one end of the cable through a cable connector installed on the output side of the first Data Enabler Pro device in the series (the side with two openings).
4. Locate the DMX output pivot connectors inside the Data Enabler Pro housing. Open both wire stuffers.

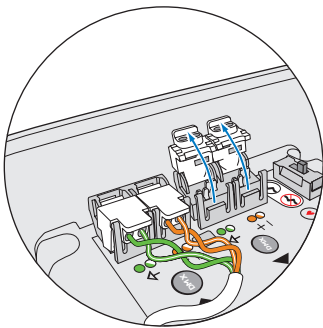

5. From right to left, following the wire color codes printed on the data board, insert the Orange / White, Orange, Green / White, and Green wires into the pivot connector's wire entry holes.

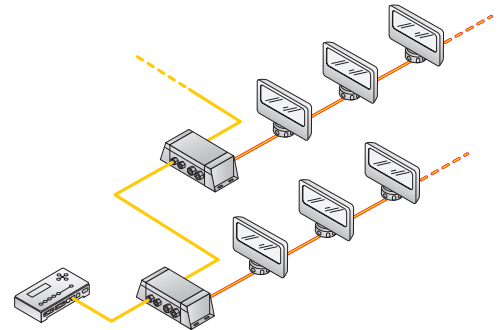
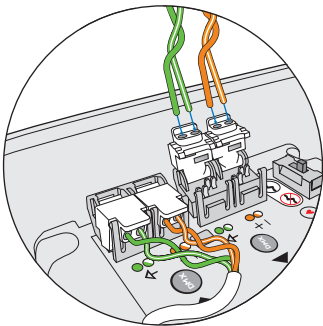

* IDC connectors accept wire sizes from 22 – 26 AWG (0.326 – 0.129 mm²).

- While holding the wires firmly in place, push down on the wire stuffers until they click shut.

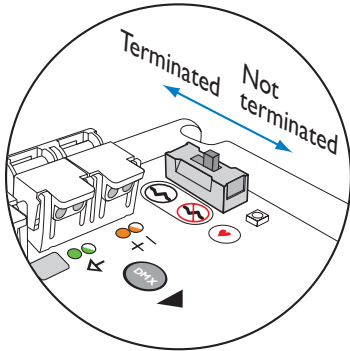
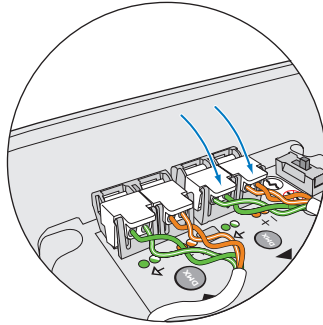
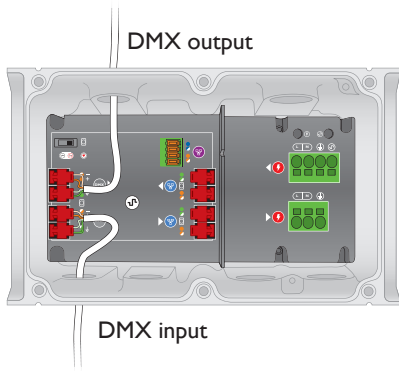

- Run the free end of the cable to the next Data Enabler Pro device in the series, and make DMX data input connections as described in the previous section.
- Repeat for each Data Enabler Pro device in the series.
- Terminate the last Data Enabler Pro device in the series using the termination switch.

Series Connection Using Ethernet

You can connect up to 15 Data Enabler Pro devices in series. Use additional Ethernet switch ports to connect additional Data Enabler Pro devices to your network.

In Ethernet networks, maximum run lengths for data cables are 328 ft (100 m) between Ethernet devices without a repeater.

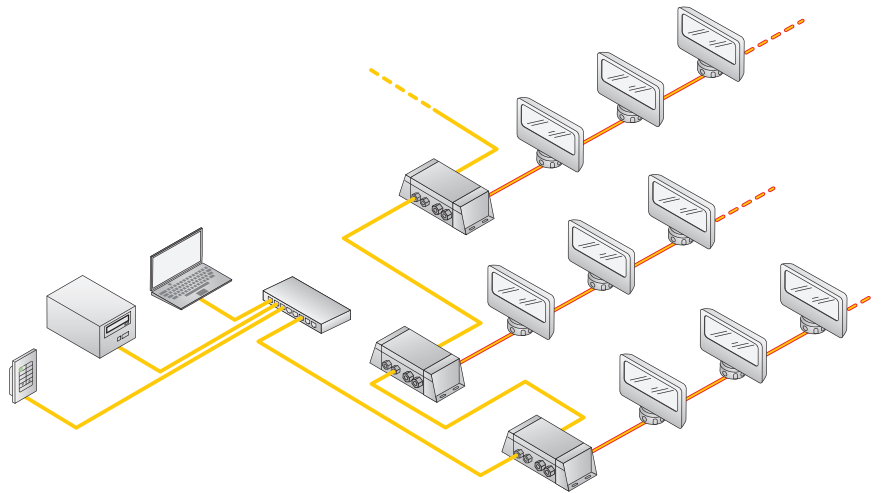
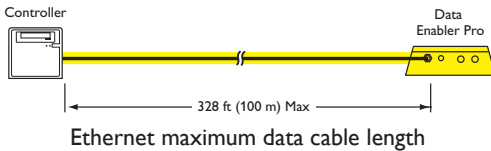

- Cut a sufficient length of CAT 5e or better cable to connect the first Data Enabler Pro device in a series with the next.
- If necessary, cut both ends of the cable jacket to expose the wire pairs. Do not strip the wire pairs.
The Brown, Brown / White, Blue, and Blue / White wires are not used and should be capped and turned back.
- Run one end of the cable through a cable connector installed on the output side of the first Data Enabler Pro device in the series (the side with two openings).

4. Locate the Ethernet output pivot connectors inside the Data Enabler Pro housing. Open both wire stuffers.

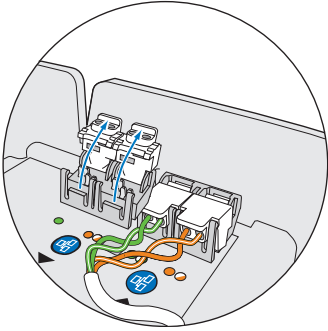

5. From right to left, following the wire codes printed on the data board, insert the Orange / White, Orange, Green / White, and Green wires into the pivot connector's wire entry holes.

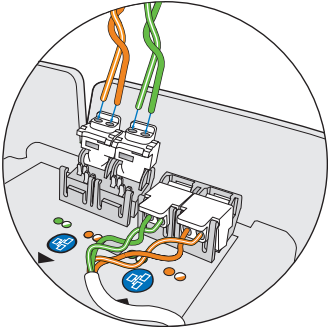

6. While holding the wires firmly in place, push down on the wire stuffers until they click shut.

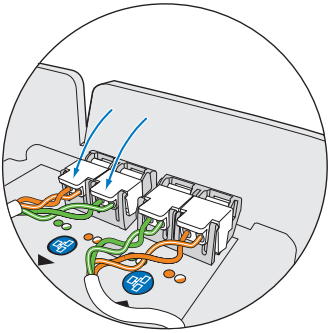

7. Run the free end of the cable to the next Data Enabler Pro device in the series, and make Ethernet data input connections as described in the previous section.
8. Repeat for each Data Enabler Pro device in the series.

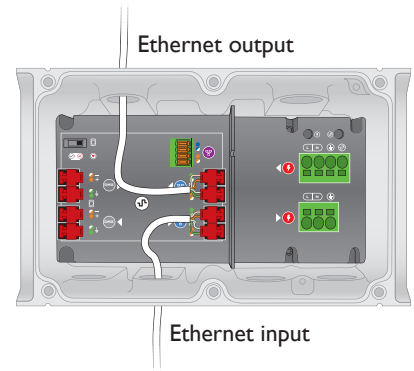

Make Mains Voltage Connections

1. Run the mains voltage power cable through a cable connector installed on the input side of the Data Enabler Pro housing (the side with the four openings). Pull at least 5 in (127 mm) of wire into the housing.
2. Strip .6 in (15 mm) of insulation from the wires. If using stranded wire, twist each wire tight to secure the wire threads.
3. Locate the mains voltage 3-wire PC terminal block connector inside the Data Enabler Pro housing.
4. Securely install line, neutral, and ground in the terminal block:
 - Insert a small flathead screwdriver in the slot above a wire entry hole.
 - Firmly insert the correct wire in the wire entry hole.
 - Remove the screwdriver.

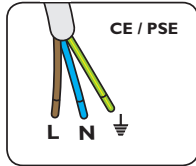
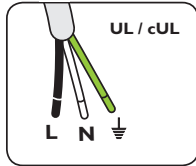
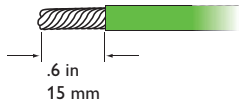

* PC terminal block connectors accept recommended wire sizes from 8 – 18 AWG (8.37 – 0.823 mm²).

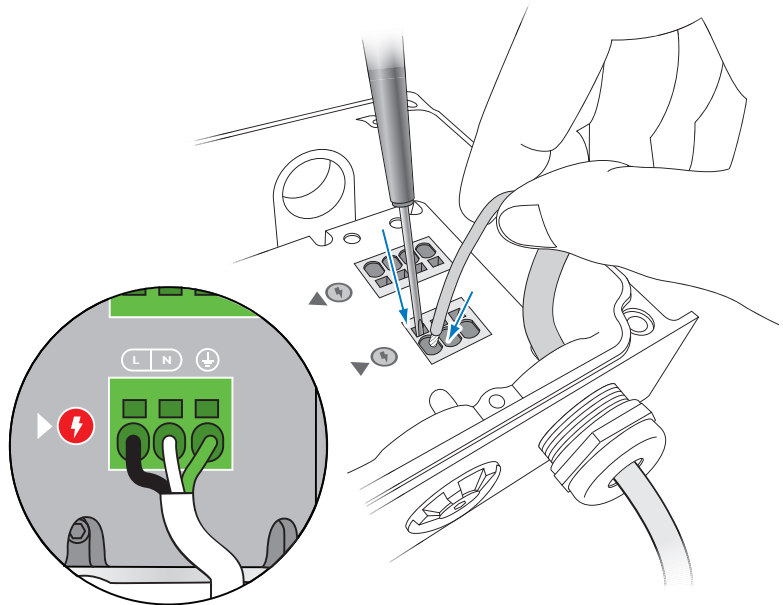
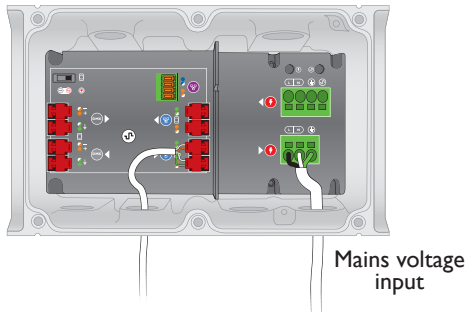

Make Fixture Cable Connections

Philips Color Kinetics intelligent LED lighting fixtures that use Data Enabler Pro either have a detachable leader cable with flying leads, or an integrated power / data cable. Leader cables range from 10 ft (3 m) to 60 ft (18.3 m), while integrated power / data cables can be as long as 12 ft (3.7 m) or as short as 6 in (152 mm).

Fixtures with integrated cables, such as ColorBlast Powercore and ColorBurst Powercore, are installed to junction boxes. For runs of fixtures installed in series, a lead wire is run from the first junction box to Data Enabler Pro. For fixtures installed in parallel (star configuration), a lead wire is run from a common junction box to Data Enabler Pro.

Fixtures with detachable leader cables, such as ColorGraze Powercore, iColor Cove MX Powercore, and iColor Accent Powercore, can be installed in single runs by connecting the leader cable directly to Data Enabler Pro. Fixtures in the run are connected together by means of integrated end-to-end connectors or jumper cables. Multiple runs of fixtures can also be connected in parallel by connecting a lead wire from a common junction box to a Data Enabler Pro.

For fixtures that do not use leader cables and jumper cables, use a sufficient length of 4-conductor copper wire to connect fixtures to each other and to Data Enabler Pro. Standard 12 AWG (3.31 mm²) stranded wire is recommended, but the wiring you use depends on local electrical codes.

1. Run a leader cable from a run of fixtures, or a lead wire from a junction box, through a cable connector installed on the output side of the Data Enabler Pro housing (the side with two openings). Drag at least 6 in (152 mm) of wire into the housing.
2. Strip .6 in (15 mm) of insulation from the wires. If using stranded wire, twist each wire tight to secure the wire threads.
3. Locate the fixture cable 4-wire PC terminal block connector inside the Data Enabler Pro housing.
4. Securely install line, neutral, ground, and data in the terminal block:
 - Insert a small flathead screwdriver in the slot above a wire entry hole.
 - Firmly insert the correct wire in the wire entry hole.
 - Remove the screwdriver.

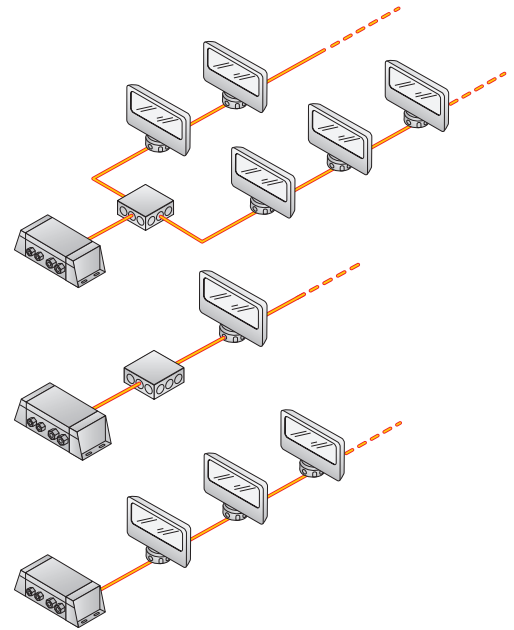

***** eW and iColor Accent MX Powercore accept direct Ethernet data input. Use the separate 4-wire IDC terminal block connector for Ethernet data output to eW and iColor Accent MX Powercore, as described in the next section.

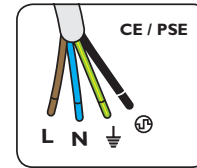
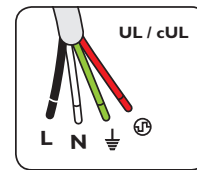
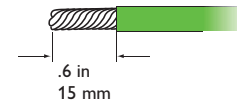

***** PC terminal block connectors accept recommended wire sizes from 8 – 18 AWG (8.37 – 0.823 mm²).

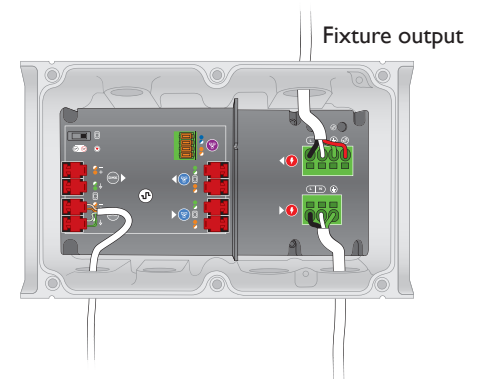
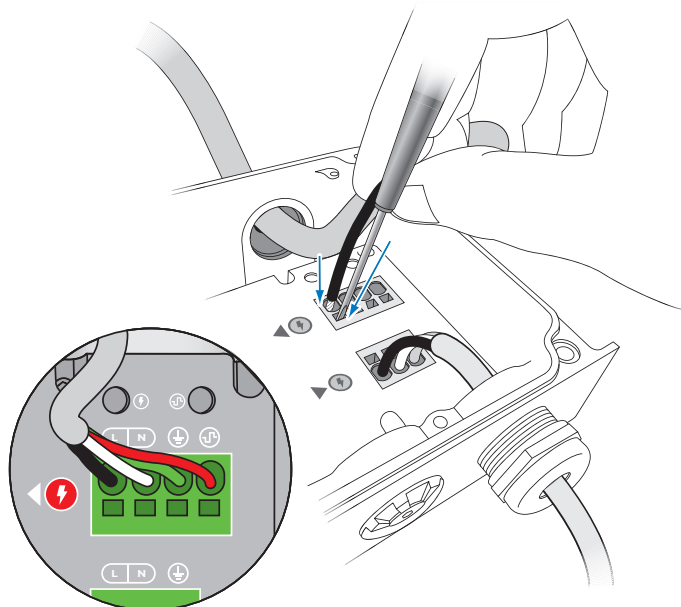

Fixture Cable Connection for eW Accent MX Powercore and iColor Accent MX Powercore

Data Enabler Pro includes a separate 4-wire IDC terminal block connector for Ethernet data output to eW and iColor Accent Powercore fixtures, which directly accept Ethernet input. Leader cables for eW and iColor Accent Powercore bundle data and power wires within the same wire jacket.

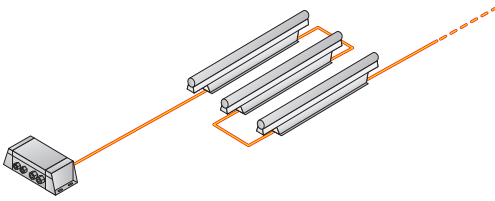

1. Run an eW or iColor Accent Powercore leader cable through a cable connector installed on the output side of the Data Enabler Pro housing (the side with two openings).
2. Strip off a sufficient length of the cable jacket to connect the data wires to the IDC terminal block on the data board and the power wires to the fixture cable PC terminal block on the power board.
2. Strip .6 in (15 mm) of insulation from the power wires. If using stranded wire, twist each wire tight to secure the wire threads.
3. Connect the data wires to the IDC terminal block:
 - Using your fingers or a small tool, lift the four punch-down connectors.
 - From right to left, following the wire codes printed on the data board, insert the Orange / White, Orange, Blue / White, and Blue wires into the wire entry holes on the front of the connector.
 - Push down each punch-down connector until they snap firmly in place.

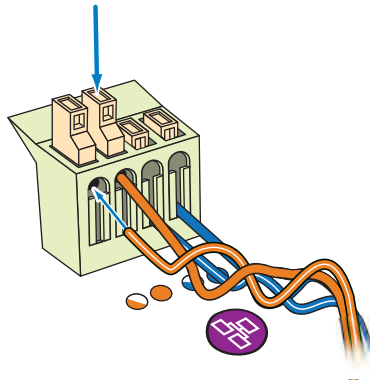

4. Securely install line, neutral, and ground in the fixture cable 4-wire terminal block:
 - Insert a standard flathead screwdriver in the slot above a wire entry hole.
 - Firmly insert the correct wire in the wire entry hole. (Leave the data position empty.)

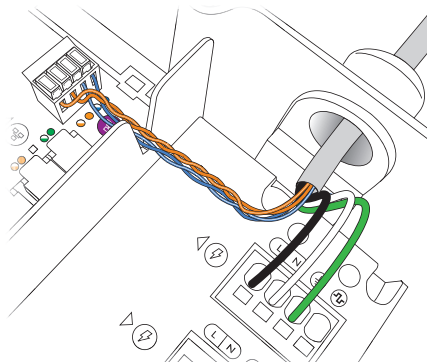
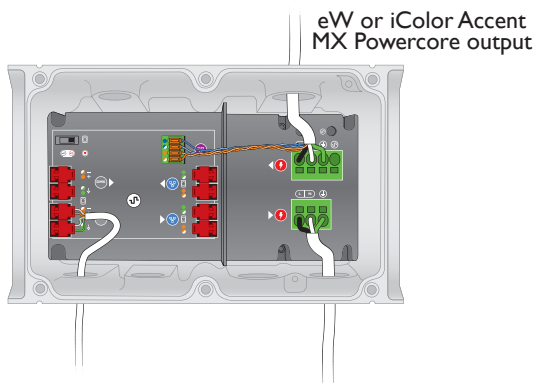

- Remove the screwdriver.

Secure Cover

Once you have finished connecting all data and power inputs and outputs, secure the Data Enabler Pro cover.

1. Seat the cover on the Data Enabler Pro housing.
2. Using the included 3 mm hex wrench, tighten the housing cover's six captured screws, in the order indicated in the diagram to the right.

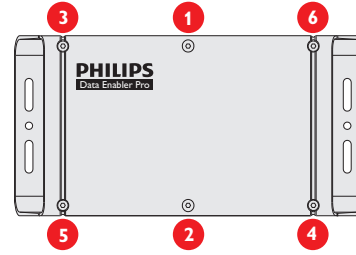
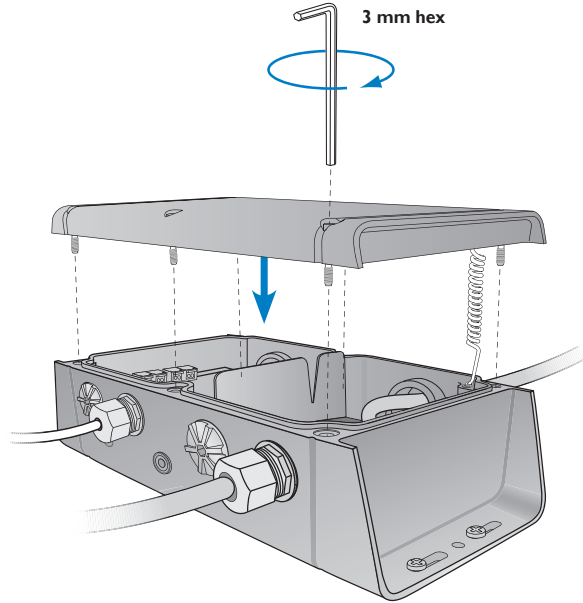

3. Torque each screw to approximately 16 in-lb (1.8 Nm).

Installing in Damp or Wet Locations

When installing in damp or wet locations, seal all junction boxes, power supplies, and other devices with electronics-grade RTV silicone sealant so that water or moisture cannot enter or accumulate in any wiring compartments, cables, fixtures, or other electrical parts. You must use suitable outdoor-rated junction boxes when installing in wet or damp locations. Additionally, you must use gaskets, clamps, and other parts required for installation to comply with all applicable local and national codes.

Configuring Data Enabler Pro with QuickPlay Pro (Optional)

You can configure Data Enabler Pro devices using QuickPlay Pro addressing and configuration software. In Ethernet installations, you can automatically discover all Data Enabler Pro devices using QuickPlay Pro with a computer connected to your lighting installation's network. In DMX installations, you can configure Data Enabler Pro devices with QuickPlay Pro by connecting a computer directly to the Ethernet input terminal block.

* You can download QuickPlay Pro from www.colorkinetics.com/support/addressing.

When a Data Enabler Pro device is connected to your lighting network, the Data Enabler Pro tab under PDS Configuration becomes active. The Data Enabler Pro tab provides options for setting DMX and power modes.

* For details on standard QuickPlay Pro options for Data Enabler and Data Enabler Pro devices, refer to the Addressing and Configuration Guide, which you can view or download at www.colorkinetics.com/support/addressing

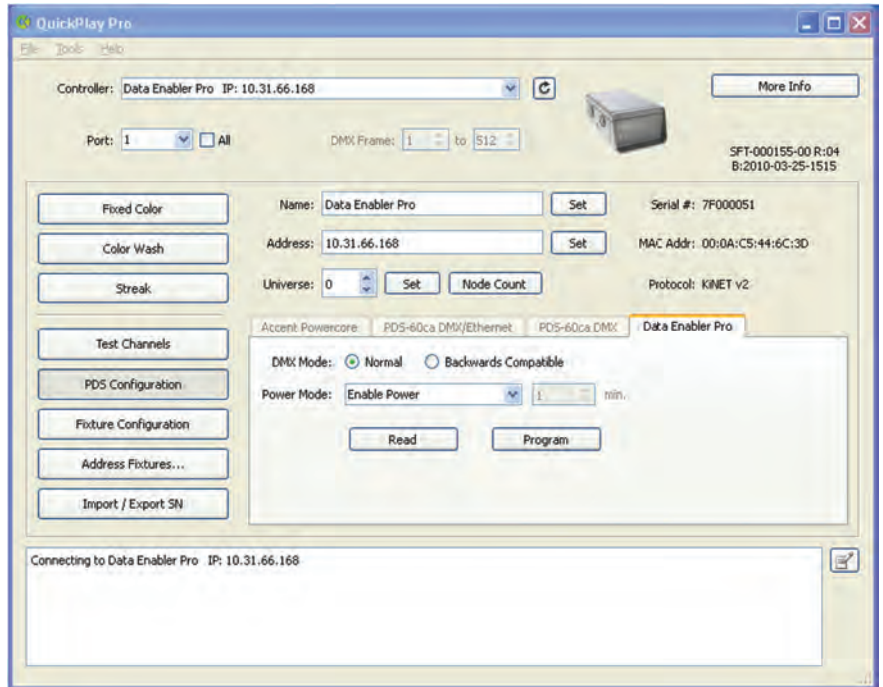

Setting DMX Mode

Under normal operation, Data Enabler Pro handles data in a slightly different manner than earlier versions of Data Enabler. Different versions, therefore, can be out of sync by one frame when used together in the same lighting network. Though small, the discrepancy could be visible in video displays or other rapidly changing light shows.

- To synchronize Data Enabler Pro with earlier versions of Data Enabler, click Backwards Compatible.
- To set Data Enabler Pro to operate normally, click Normal (the default).

Setting Power Mode

To maximize energy efficiency, optional power-saving modes automatically cut power to attached lights when lights are off for a configurable number of minutes. Use the Power Mode drop-down list to set Data Enabler Pro power mode.

- To send power to connected lights at all times, select Enable Power (the default). (Lights continue to draw power even when receiving no data or black data.)
- To cut power to connected lights at all times, select Disable Power. (Lights remain off even when receiving non-black data.)

* Click the Refresh button after changing the power mode, as available controller and fixture options may have changed.

- To cut power to connected lights after receiving no data for a period of time, select “Turn off after no data for,” and enter a timeout (in minutes) in the text box. Power is automatically restored to connected lights when data flows again.
- To cut power to connected lights after receiving black data (DMX packets with all data fields set to 0) for a period of time, select “Turn off after black data for,” and enter a timeout (in minutes) in the text box. Power is automatically restored to connected lights when non-black data flows again.

Updating Data Enabler Pro Firmware

The Data Enabler Pro firmware image is periodically updated to improve system performance and functionality. To maximize system performance, make sure your Data Enabler Pro devices are running the most recent version of the firmware. We recommend that you confirm that your Data Enabler Pro devices have the most recent version of the firmware before installing them in your lighting network.

Determine Data Enabler Pro Firmware Version

1. You can determine the firmware version that your Data Enabler Pro devices are running with a computer and QuickPlay Pro:
 - In Ethernet installations, connect a computer to the lighting network and run QuickPlay Pro. QuickPlay Pro automatically discovers all connected Data Enabler Pro devices. Select a device from the Controllers drop-down list.
 - In DMX installations, directly connect a computer to the Ethernet input port inside the Data Enabler Pro housing, and run QuickPlay Pro.
2. If necessary, select a Data Enabler Pro device from the Controllers drop-down list.

The firmware version for the selected Data Enabler Pro device appears at the top of the QuickPlay Pro window, on the right.

 You can download QuickPlay Pro from www.colorkinetics.com/support/addressing.

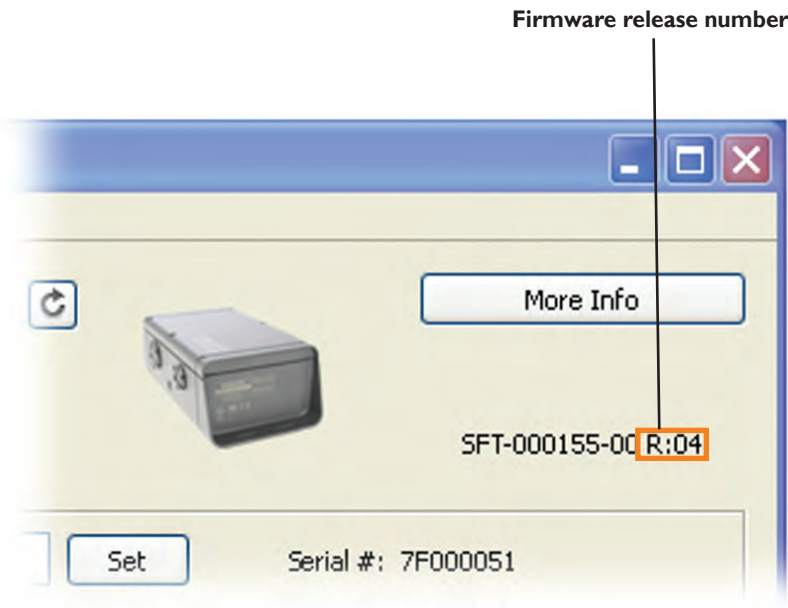

Download Data Enabler Pro Firmware

If a more recent version of the Data Enabler Pro firmware is available, download the firmware file (.hex extension):

1. Visit the Firmware Updater page at www.colorkinetics.com/support/downloads/firmware/ to check for the latest firmware version.
2. If a newer firmware image is available, click the link on the Firmware Updater page to download the firmware file to an accessible location on your computer.

Download CK Firmware Updater

To update the firmware image on a Data Enabler Pro device, you must download and install the CK Firmware Updater application on your computer.

1. Visit the Firmware Updater page at www.colorkinetics.com/support/downloads/firmware/
2. Download the CK Firmware Updater installer.
3. Decompress the file to an accessible location on your computer and open it.
4. Run the installer, and follow the on-screen instructions.

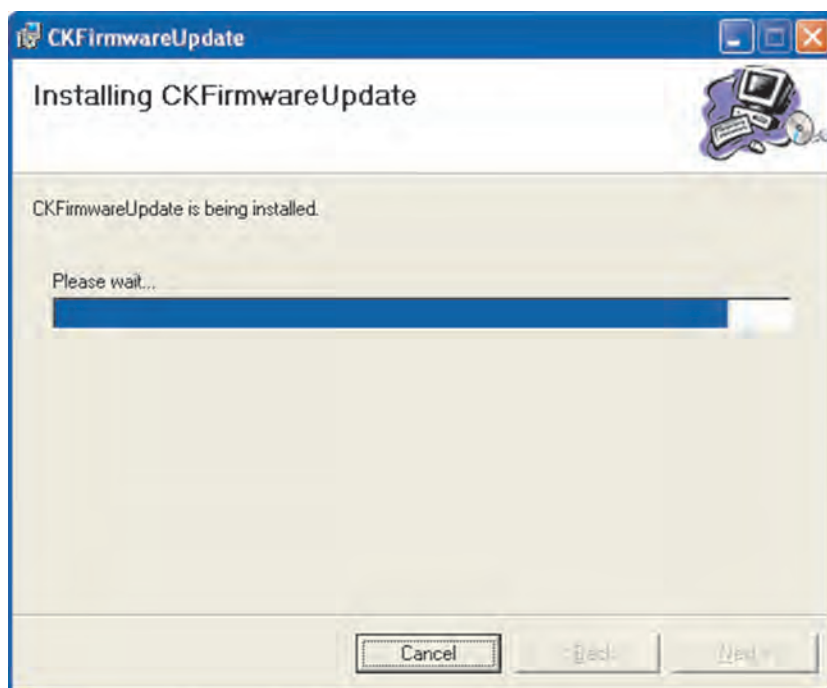

Running a Data Enabler Pro Firmware Update (Ethernet network)

1. Connect a computer to the lighting network, and run CK Firmware Updater.
2. From the Interface Select drop-down list, select Ethernet Controllers.
3. From Device Select drop-down list, select Data Enabler Pro.
4. Click File Select, navigate to the folder to which you downloaded the firmware file (.hex extension), and click Open.
5. Click Discover. CK Firmware Updater automatically discovers all Data Enabler Pro devices connected to your lighting network.
6. Select a Data Enabler Pro device and click PROGRAM.
7. Repeat step 6 for each Data Enabler Pro device that you want to update.

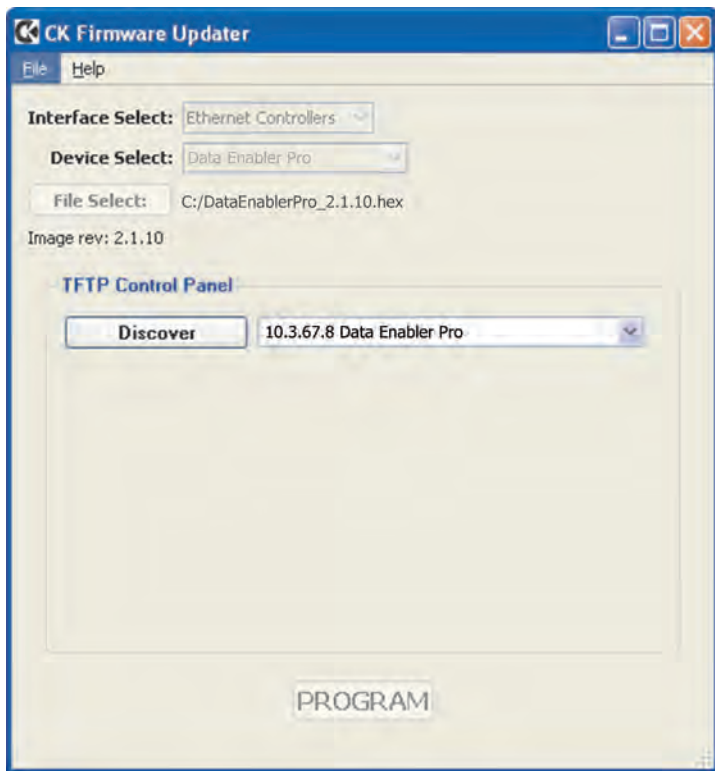

Running a Data Enabler Pro Firmware Update (DMX network)

1. Directly connect a computer to the Ethernet input port inside the housing of a Data Enabler Pro device that you want to update
2. Run CK Firmware Updater.
3. From the Interface Select drop-down list, select Ethernet Controllers.
4. From the Device Select drop-down list, select Data Enabler Pro.
5. Click File Select, navigate to the folder to which you downloaded the firmware file (.hex extension), and click Open.
6. Click Discover. CK Firmware Updater discovers the Data Enabler Pro device to which your computer is currently connected.
7. Click PROGRAM.
8. Repeat steps 1 – 7 for each Data Enabler Pro device that you want to update.

Recovering from Firmware Update Errors

In rare instances, you may experience power or data loss or interruption during the firmware update process. In such cases, a Data Enabler Pro device may receive an incomplete or corrupt firmware image. You must successfully re-install the firmware image to restore normal Data Enabler Pro operations.

✳️ *When the firmware is corrupt or incomplete, the DMX and “heartbeat” indicator lights inside the Data Enabler Pro housing blink rapidly.*

- In the case of power loss or interruption, the Data Enabler Pro device retains its assigned IP address, but you are temporarily unable to communicate with the device using that address.

If this happens, enter the reserved IP address 10.1.250.250 in CK Firmware Updater, and re-install the firmware image.

Once the firmware image is successfully installed, you can again communicate with the Data Enabler Pro device using its assigned IP address.

- In the case of data loss or interruption, you must manually enter the device’s IP address in CK Firmware Updater to re-install the firmware image.

If you don’t know the device’s assigned IP address, you can cycle power, then use the reserved IP address 10.1.250.250, as described above.



Philips Color Kinetics
3 Burlington Woods Drive
Burlington, Massachusetts 01803 USA
Tel 888.385.5742
Tel 617.423.9999
Fax 617.423.9998
www.philipscolorkinetics.com

Copyright © 2010 – 2011 Philips Solid-State Lighting Solutions, Inc. All rights reserved.
Chromacore, Chromasic, CK, the CK logo, Color Kinetics, the Color Kinetics logo, ColorBlast,
ColorBlaze, ColorBurst, eW Fuse, ColorGraze, ColorPlay, ColorReach, iW Reach, eW Reach,
DIMand, EssentialWhite, eW, iColor, iColor Cove, IntelliWhite, iW, iPlayer, Optibin, and Powercore
are either registered trademarks or trademarks of Philips Solid-State Lighting Solutions, Inc. in
the United States and / or other countries. All other brand or product names are trademarks
or registered trademarks of their respective owners. Due to continuous improvements and
innovations, specifications may change without notice.
Cover Photo: Sands Resort Casino Bethlehem, by Alyssa Csük DAS-000052-00 R02 01-11