



# ColorBlaze TRX

Advanced theatrical and rental LED batten with intelligent RGBAW light



# ColorBlaze TRX

## Advanced theatrical and rental LED batten with intelligent RGBAW light

ColorBlaze TRX is a versatile, feature-packed linear RGBAW LED fixture with industry-leading light output. Available in two-foot and six-foot lengths, these powerful, stage-ready fixtures incorporate channels of red, green, blue, amber, and white LED sources to achieve superior color precision and a dramatically expanded color palette. ColorBlaze TRX is the ideal solution for theatrical and rental distributors, exhibition houses, theaters, nightclubs, and other entertainment venues.

- Versatile, intense light output — ColorBlaze TRX fixtures outperform the competition with light output of up to 3,540 lumens per foot. Controllable in increments of 4 in (102 mm) to 6 ft (1.8 m), fixtures deliver stunning effects and intense washes of color for flooding surfaces and stages. Native 10° beam angle and available spread lenses of 22°, 32°, 60° x 32°, and 32° x 12° offer multiple options for directing and dispersing light.
- Flexible color control — Choose from five-channel RGBAW in / out, three-channel RGB in / out, and three-channel RGB in mapped to five-channel RGBAW out. RGB modes offer consistent operation with traditional RGB LED fixtures such as ColorBlaze 48 and ColorBlaze 72.
- Superior color consistency and accuracy — Optibin, an advanced binning algorithm, sets a new standard for the color consistency and uniformity of LED sources used in manufacturing. Chromasync technology achieves unprecedented consistency of light performance and color precision across multiple fixtures in an installation, while maximizing intensity and color range.
- Field serviceable for on-site maintenance — Most fixture components are field-serviceable and replaceable.
- Advanced on-board controls — On-board controls offer access to all functions and features, including addressing, diagnostics, and more.
- Advanced dimming and channel control — 16-bit resolution supports smooth dimming and precise color control. Adjustable dimming curves and LED transition speeds emulate the behavior of other Philips Color Kinetics fixtures and conventional theatrical fixtures with DMX dimming.
- Data input and standalone modes — Accepts DMX or Ethernet input from a full range of Philips controllers, as well as third-party DMX and Ethernet controllers. Standalone mode offers both pre-set effects and the ability to play custom light shows stored on the installed SD card.
- Control options for architectural, entertainment, and portable applications — Master / slave mode lets you configure a ColorBlaze TRX fixture to act as a master controller for other fixtures in a run. A configurable DMX trigger allows activation of 10 custom triggers from a lighting console. Activate up to eight triggers with Ethernet Controller Keypad, our wall-mounted Power-over-Ethernet keypad.
- Versatile mounting options — Clamp-mount ColorBlaze TRX to pipes or trusses, or mount directly to a surface. Industrial-grade constant torque hinges and locking handles offer stable, 165° rotation for dependable aiming and locking.
- Universal, integrated power supply — Auto-switching power supply accepts power input of 100 – 240 VAC, eliminating additional equipment and enabling consistent use around the world.



### Expanded Color Palette

Channels of amber and neutral white LEDs seamlessly blend with channels of red, green, and blue LEDs to produce a significantly expanded color palette. ColorBlaze TRX adds intense yellows, high-quality whites, and a range of subtle pastel colors to the millions of saturated colors achievable with standard RGB lighting fixtures.

# Photometrics

Photometric data is based on test results from an independent NIST traceable testing lab. IES data is available at [www.philipscolorkinetics.com/support/ies](http://www.philipscolorkinetics.com/support/ies).

## ColorBlaze TRX 2 ft (610 mm), no spread lens

LED	Lumens	Efficacy
RGB	7079	23.8

### Polar Candela Distribution

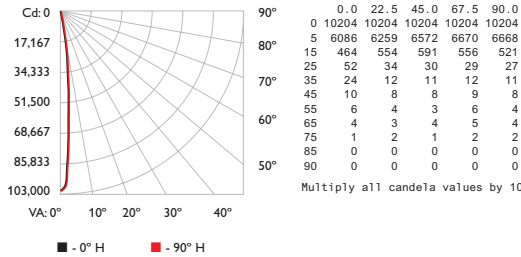

### Illuminance at Distance

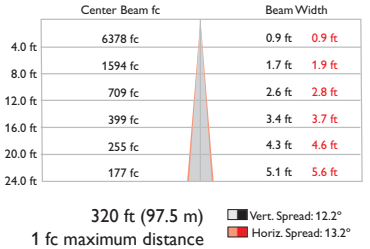

### Zonal Lumen

ZONE	LUMENS	%FIXT
0- 30	6828	96.4
0- 40	6917	97.7
0- 60	7026	99.2
0- 90	7079	100.0
90-180	0	0.0
0-180	7079	100.0

### Coefficients Of Utilization - Zonal Cavity Method

RC	Effective Floor Cavity Reflectance: 20%											
	80		70		50		30		10		0	
RW	70	50	30	10	70	50	30	10	50	30	10	0
0	119119119119	116116116116	1111111111	106106106	102102102	100						
1	116114112111	113112110109	108107106	104103103	101100100	98						
2	113110107105	111108106104	105103102	102101100	100	99	98	96				
3	110107104101	109105103100	103101	99	101	99	97	99	97	96	95	
4	108104101	98	107103100	98	101	98	97	99	97	96	97	96
5	106101	98	96	105101	98	95	99	97	95	98	96	94
6	104	99	96	94	103	99	96	94	97	95	93	95
7	102	98	94	92	101	97	94	92	96	93	92	95
8	101	96	93	91	100	95	93	91	95	92	90	94
9	99	94	92	90	99	94	91	89	93	91	89	92
10	98	93	90	88	97	93	90	88	92	90	88	91

## ColorBlaze TRX 2 ft (610 mm), 22° spread lens

LED	Lumens	Efficacy
RGB	6008	20.2

### Polar Candela Distribution

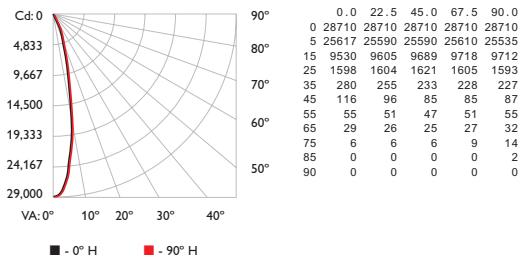

### Illuminance at Distance

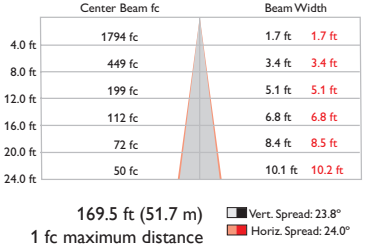

### Zonal Lumen

ZONE	LUMENS	%FIXT
0- 30	5678	94.5
0- 40	5651	97.4
0- 60	5969	99.4
0- 90	6008	100.0
90-180	0	0.0
0-180	6008	100.0

### Coefficients Of Utilization - Zonal Cavity Method

RC	Effective Floor Cavity Reflectance: 20%											
	80		70		50		30		10		0	
RW	70	50	30	10	70	50	30	10	50	30	10	0
0	119119119119	116116116116	1111111111	106106106	102102102	100						
1	115113111109	113111109107	107105104	103102101	100	99	98	97				
2	111107104102	109106103101	103101	99	100	98	97	97	96	95	93	
3	108103	99	96	106102	98	96	99	96	94	97	95	93
4	104	99	95	92	103	98	94	91	96	93	90	88
5	101	95	91	88	100	94	91	88	93	90	87	85
6	98	92	88	85	97	91	87	85	90	87	84	88
7	96	89	85	82	94	89	85	82	87	84	81	86
8	93	86	82	79	92	86	82	79	85	82	79	84
9	91	84	80	77	90	84	80	77	83	79	77	81
10	88	82	78	75	88	81	78	75	81	77	75	79

For lux multiply fc by 10.7

## ColorBlaze TRX 2 ft (610 mm), 32° spread lens

LED	Lumens	Efficacy
RGB	6008	19.7

### Polar Candela Distribution

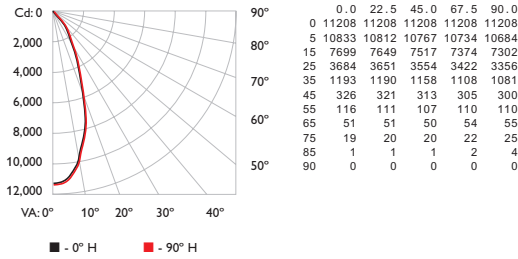

### Illuminance at Distance

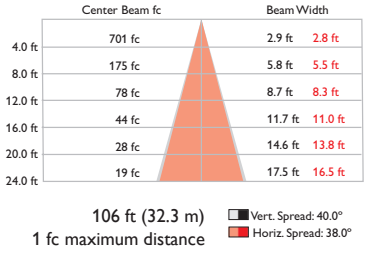

### Zonal Lumen

ZONE	LUMENS	%FIXT
0- 30	4678	79.7
0- 40	5428	92.5
0- 60	5791	98.7
0- 90	5868	100.0
90-180	0	0.0
0-180	5868	100.0

### Coefficients Of Utilization - Zonal Cavity Method

RC	Effective Floor Cavity Reflectance: 20%											
	80		70		50		30		10		0	
RW	70	50	30	10	70	50	30	10	50	30	10	0
0	119119119119	116116116116	111111111111	106106106	102102102	100						
1	114111109107	111109107105	105103102	10110099	98979694							
2	10910410097	1061029996	99969496	949087	918886	89878583						
3	104989389	102969289	949087	898582	878381	85828078						
4	99928783	97918683	848077	837976	81787574							
5	95878278	93868177	807672	797572	78747170							
6	91827773	89827673	767268	757168	74706866							
7	87787369	85787269	736865	726865	71676463							
8	83746965	82746965	706562	696561	68646160							
9	80716662	79716562	676259	666259	65615857							
10	77686359	76676259										

## ColorBlaze TRX 2 ft (610 mm), 32° x 12° spread lens

LED	Lumens	Efficacy
RGB	6018	20.2

### Polar Candela Distribution

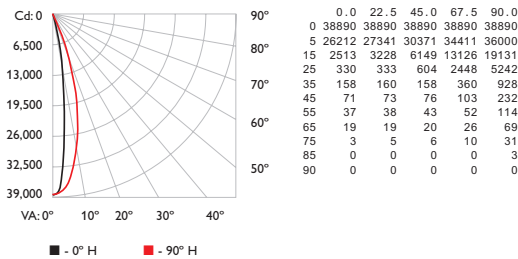

### Illuminance at Distance

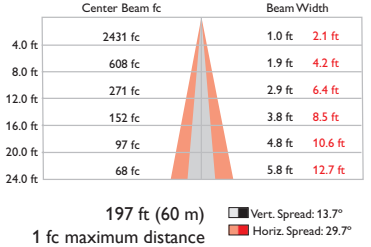

### Zonal Lumen

ZONE	LUMENS	%FIXT
0- 30	5639	93.7
0- 40	5850	97.2
0- 60	5979	99.4
0- 90	6018	100.0
90-180	0	0.0
0-180	6018	100.0

### Coefficients Of Utilization - Zonal Cavity Method

RC	Effective Floor Cavity Reflectance: 20%											
	80		70		50		30		10		0	
RW	70	50	30	10	70	50	30	10	50	30	10	0
0	119119119119	116116116116	111111111111	106106106	102102102	100						
1	115113111109	113111109108	107106104	103102101	100999897							
2	111108105102	109106103101	10310199	1009897	97969593							
3	10810310097	1061029996	999795	979593	95939291							
4	105999592	103989592	969391	949290	93918988							
5	102969289	100959189	939088	928987	91888685							
6	99938986	98928886	918785	908784	88868483							
7	96908683	95898683	888582	878482	86848281							
8	94878381	93878381	868380	858280	84828079							
9	92858179	91858178	848178	838078	83807877							
10	89837977	89837976	827976	817876	81787675							

For lux multiply fc by 10.7

**ColorBlaze TRX**  
**2 ft (610 mm), 60° x 32° spread lens**

LED	Lumens	Efficacy
RGB	5815	19.5

**Polar Candela Distribution**

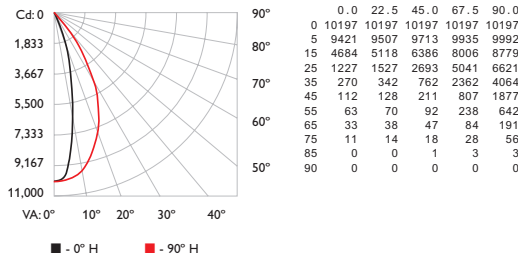

**Illuminance at Distance**

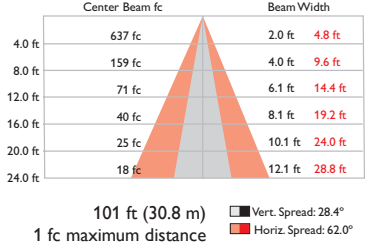

**Zonal Lumen**

ZONE	LUMENS	%FIXT
0- 30	4213	72.4
0- 40	5111	87.9
0- 60	5715	98.3
0- 90	5815	100.0
90-180	0	0.0
0-180	5815	100.0

**Coefficients Of Utilization - Zonal Cavity Method**

Effective Floor Cavity Reflectance: 20%

RC	80			70			50			30			10			0
RW	70	50	30	10	70	50	30	10	50	30	10	50	30	10	0	
0	119119119119	116116116116	111111111111	106106106	102102102	100										
1	113111108106	111109106104	105103101	1019998	979695	93										
2	1081039996	1061019895	989592	959390	929089	87										
3	103969187	101959087	928885	908784	888583	81										
4	98908580	96898480	878279	858178	838077	76										
5	93857975	91847874	827774	807673	797572	71										
6	88807470	87797369	777369	767269	757168	67										
7	84756965	83756965	736865	726865	716764	63										
8	81716662	79716561	706561	696461	686461	59										
9	77686258	76676258	666158	656158	656158	56										
10	74645955	73645955	635855	635855	625855	53										

For lux multiply fc by 10.7

# Specifications

Due to continuous improvements and innovations, specifications may change without notice.

Item	Specification	2 ft (610 mm)	6 ft (1.8 m)
Output	Beam Angle	10° native (no spread lens)	
	LED Channels	Red / Green / Blue / Amber / White	
	Lumens*	7079 (2 ft length, RGBAW channels full on)	
	Lumen Maintenance†	50,000 hours L50 @ 25° C 35,000 hours L50 @ 50° C	
Electrical	Input Voltage	100 – 240 VAC, auto-switching, 50 / 60 Hz	
	Power Consumption	315 W maximum at full output, steady state	930 W maximum at full output, steady state
Control	Interface	DMX or 10/100 Ethernet. Fixture firmware addressable 8- and 16-bit control, RGBAW, and RGB modes.	
	Control System	Philips full range of controllers, including Video System Manager Pro and Light System Manager, or third-party controllers	
Physical	Dimensions (Height x Width x Depth)	9.3 x 24 x 6.7 in (236 x 610 x 170 mm)	9.3 x 72 x 6.7 in (236 x 1829 x 170 mm)
	Weight	16.2 lb (7.3 kg)	43 lb (19.5 kg)
	Housing	Extruded aluminium and polymer, black finish	
	Lens	Clear polycarbonate	
	Fixture Connections	Neutrik PowerCon Power Connector RJ45 and XLR-5 data connections	
	Temperature Ranges	-40° – 122° F (-40° – 50° C) Operating 32° – 122° F (0° – 50° C) Startup -40° – 122° F (-40° – 50° C) Storage	
	Humidity	0 – 95%, non-condensing	
Certification and Safety	Certification	UL / cUL, FCC Class A, CE	
	Environment	Dry Location, IP20	

\* Lumen measurement complies with IES LM-79-08

† L50 = 50% lumen maintenance (when light output drops below 50% of initial output). Ambient luminaire temperatures specified. Lumen maintenance calculations are based on lifetime prediction graphs supplied by LED source manufacturers. Calculations for white-light LED fixtures are based on measurements that comply with IES LM-80-08 testing procedures. Refer to [www.philipscolorkinetics.com/support/appnotes/lm-80-08.pdf](http://www.philipscolorkinetics.com/support/appnotes/lm-80-08.pdf) for more information.

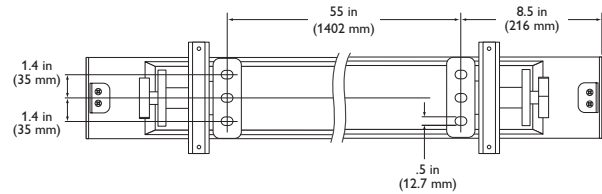
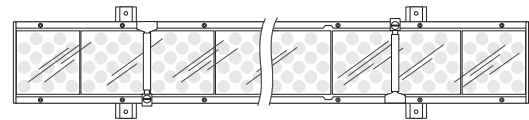
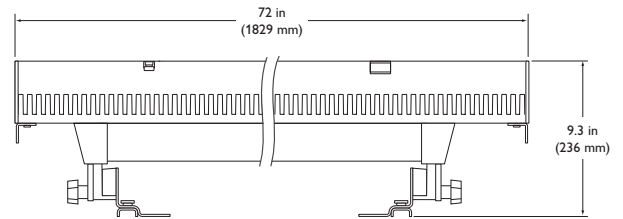
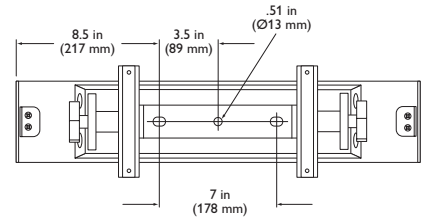
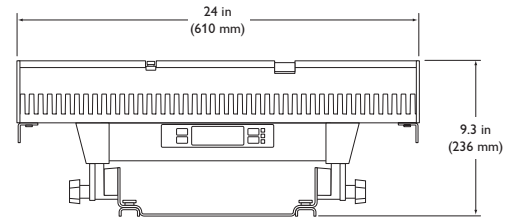
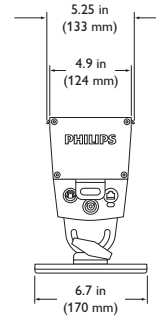

CHROMACORE<sup>®</sup> CKTECHNOLOGY | CHROMASYNC<sup>®</sup> CKTECHNOLOGY | OPTIBIN<sup>®</sup> CKTECHNOLOGY

## Included in the box

ColorBlaze TRX fixture
Neutrik PowerCon connector
Ferrite core for EMI suppression

## Fixtures, Lenses, and Replacement Parts

ColorBlaze TRX fixtures are part of a complete system which includes a full range of Philips controllers, including Video System Manager Pro, Light System Manager, and iPlayer 3, or a third-party controller, and RJ45 or XLR-5 data cables for connecting fixtures together in series or to controllers, and power cables using Neutrik PowerCon connectors for connecting fixtures to power, or for connecting multiple fixtures to a single circuit.

Item	Type	Item Number	Philips 12NC
ColorBlaze TRX	2 ft	116-000028-00	910503701741
	6 ft	116-000028-01	910503701742
Spread Lenses, 2 ft	22°	120-000109-00	910503701959
	32°	120-000109-01	910503701960
	60° x 32°	120-000109-02	910503701961
	32° x 12°	120-000109-03	910503701962
LED board assembly		120-000127-00	910503701963
Power supply / filter board assembly with battery holders	Center unit	120-000128-00	910503701964
Power supply / filter board assembly without battery holders	End units	120-000128-01	910503701965
Control board with OLED display, UI components, and UI buttons		120-000129-00	910503701966
Fan assembly		120-000130-00	910503701967
Primary lens, 2 ft		120-000131-00	910503701968
Primary lens, 6 ft		120-000131-01	910503701969
LED board carrier		120-000132-00	910503701970
Secondary lens rail pair, 2 ft		120-000133-00	910503701971
Secondary lens rail pair, 6 ft		120-000133-01	910503701972
Lens clip assembly, pair		120-000134-00	910503701973
Diffuser spacer assembly, pair		120-000134-01	910503701974
Top end cap assembly, pair		120-000135-00	910503701974
Yoke with mounting feet (for 2 ft unit only)		120-000136-00	910503701975
Trunion with mounting foot, pair		120-000137-00	910503701976
Thermoplastic T-handle, pair		120-000138-00	910503701977
End cap rotation bracket assembly, input side		120-000139-00	910503701978
End cap rotation bracket assembly, output side		120-000139-01	910503701978
Input connector board assembly		120-000140-00	910503701979
Output connector board assembly		120-000140-01	910503701980
Optic tray assembly with optics, pair		120-000141-00	910503701981
Back cover, 2 ft		120-000142-00	910503701982
Back cover, 6 ft		120-000142-01	910503701983
Power distribution board assembly, 2 ft section		120-000143-00	910503701984

ColorBlaze TRX field replaceable units

 Field replaceable units (FRUs) must be installed by trained / qualified personnel in accordance with procedures detailed in the ColorBlaze TRX Service Manual.

Use Item Number when ordering in North America.

# Installation

ColorBlaze TRX fixtures have integrated power supplies and onboard menus, located on the front of the fixture, for addressing and other functions. These features, along with remote configuration capabilities and flexible mounting hardware, make ColorBlaze TRX fixtures easy to set up, configure, and tear down.

## Owner / User Responsibilities

It is the responsibility of the contractor, installer, purchaser, owner, and user to install, maintain, and operate ColorBlaze TRX fixtures in such a manner as to comply with all applicable codes, state and local laws, ordinances, and regulations. Consult with the appropriate electrical inspector to ensure compliance.

 Refer to the ColorBlaze TRX Installation Instructions for specific warning and caution statements.

# Planning Your Installation

ColorBlaze TRX is a highly flexible, capable LED lighting fixture with multiple points of control. Your approach to addressing, configuring, and mounting ColorBlaze TRX fixtures will differ depending on your situation:

- In simple installations using pre-programmed light shows, a lighting board, or DMX controller, you may not need to perform any onboard or per-fixture addressing.
- In rental, touring, and other temporary installations, it's often advantageous to address and configure fixtures in a preparation area before hanging or mounting them. Doing so requires you to power up the fixtures, configure them with the onboard controls, and install any spread lenses or other accessories. At the installation site, the fixtures must be hung or mounted and connected to power.

In architectural applications where fixtures are mounted permanently against flat surfaces, in niches, or in other areas that may be difficult to access, we strongly recommend configuring ColorBlaze TRX fixtures before installing them.

- In permanent installations, fixtures are likely to be installed in fixed locations and reconfigured for different purposes and events. In such situations, you can configure ColorBlaze TRX fixtures in position using the onboard controls, or you can perform certain configurations over the lighting network using a personal computer and QuickPlay Pro addressing and configuration software.

 You can configure ColorBlaze TRX fixtures on battery power, without connecting them to AC power.

Because it's the most common situation, the installation sections that follow describe the process for a rental or touring installation, where fixtures are addressed and configured in a preparation area, then hung at the installation site.

## DMX or Ethernet?

ColorBlaze TRX fixtures can accept either DMX or Ethernet (KiNET) data input. Because of addressing limitations, DMX is appropriate for relatively simple installations, or for light shows in which multiple fixtures operate in unison. A DMX universe consists of 512 addresses, while ColorBlaze TRX fixtures can consume from 3 to 216 DMX addresses each, depending on length and configuration.

Because it is not subject to DMX addressing limitations, Ethernet is the preferred environment for intricate, color-changing light shows and video displays, in which each fixture node must be controlled individually. In an Ethernet lighting network, each ColorBlaze TRX fixture effectively functions as its own universe, identified by the fixture's unique IP address. Depending on your controller, Ethernet installations can have tens of thousands of unique, individually controllable nodes — in some cases, hundreds of thousands.

A typical DMX installation uses a DMX controller such as iPlayer 3, or a third-party DMX lighting control board. ColorBlaze TRX devices can be connected in series to a controller's DMX output port. The number of fixture runs is limited by the number of DMX output ports on each controller.



A typical Ethernet installation uses one or more Ethernet switches, and an Ethernet controller such as Light System Manager or Video System Manager Pro. You can connect a series of up to 15 ColorBlaze TRX fixtures to each available Ethernet port.

### Creating a Lighting Design Plan

Regardless of the details of your installation, it's good practice to create a lighting design plan that identifies your fixtures, details their addresses and other configuration information, and identifies their locations in relation to other required hardware. For complex installations displaying light shows with dynamic effects, such a lighting design plan is essential.

To create a lighting design plan, determine the appropriate location of each ColorBlaze TRX fixture in relation to power sources and controllers. On an architectural diagram or other diagram that shows the physical layout of the installation, identify the locations of all controllers, fixtures, power sources, and cables. To streamline installation and aid in light show programming, you can affix a label identifying the order or placement in the installation to an inconspicuous location on each ColorBlaze TRX fixture's housing.

Keep the following considerations in mind when planning your installation:

- The integrated, auto-switching power supply automatically adjusts to any 50 / 60 Hz power source from 100 – 240 VAC. Each ColorBlaze TRX fixture includes a Neutrik PowerCon connector to which you can connect a power cable with flying leads appropriate for your geographic location.
- You can connect ColorBlaze TRX data control in series, using XLR-5 data cables for DMX, or Ethercon or RJ45 for Ethernet.
- ColorBlaze TRX fixtures can work as a single pixel, or you can set fixtures to have multiple segments that display different colors simultaneously for dynamic effects. Segment lengths can be as small as 4 in (102 mm) or as large as the entire fixture — 2 ft (610 mm) or 6 ft (1.8 m). When installing fixtures end-to-end, you can create virtual segments that span multiple fixtures.
- You can mix 2 ft and 6 ft ColorBlaze TRX fixtures in a single run. A mixture of fixture lengths can offer flexibility in architectural applications where you need to install fixtures around corners or in confined areas.
- Using a combination of Neutrik PowerCon power in and power out connectors, you can connect a run of multiple ColorBlaze TRX fixtures from a single power source.

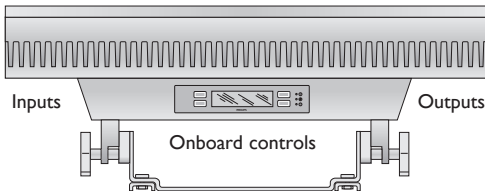

Power and data inputs



Power and data outputs

### Data Configuration Guidelines

You can mount ColorBlaze TRX fixtures end-to-end, or you can space them however you wish, so long as you follow these data configuration guidelines:

- In DMX networks using shielded XLR-5 data cables, maximum data run lengths are 1,640 ft (500 m). The maximum number of DMX devices that can be connected in series is 32. We recommend using DMX repeaters for runs that exceed the maximum length, as well as for runs of more than 32 DMX devices connected in series.

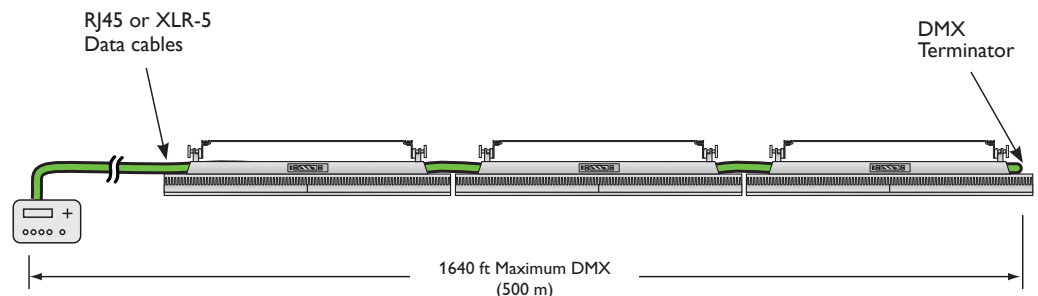

- In Ethernet networks, maximum data cables lengths are 328 ft (100 m) between Ethernet devices without a repeater (for example, controller to switch, switch to ColorBlaze TRX fixture, or fixture to fixture). You can connect up to 15 ColorBlaze TRX fixtures in series.

### Power Configuration Guidelines

For proper power management, ColorBlaze TRX fixtures should be installed on a separate power circuit of 20 A maximum. We recommend using 3-conductor 12 AWG (3.3 mm<sup>2</sup>) stranded copper wire for power cables.

You can connect multiple ColorBlaze TRX in series on a single circuit. The maximum number of fixtures each circuit can support depends on fixture power consumption (fixture length), voltage, and power cable lengths. The table to the right lists maximum run lengths for fixtures and power cables per circuit at different voltages. Keep in mind that these figures, provided as a guideline, are accurate for the specified configuration only. Changing the configuration can affect the run lengths.

## Unpack Fixtures

1. As you unpack ColorBlaze TRX, carefully inspect the box and contents for any damage that may have occurred in transit. Because each 6 ft ColorBlaze TRX fixture is bulky and weighs 43 lb (19.5 kg), you may need two people to lift the fixture out of the box.
2. Each ColorBlaze TRX fixture is assigned a date code and unique serial number. We recommend recording the serial numbers and date codes in a layout grid (typically a spreadsheet or list) to aid in servicing and troubleshooting.

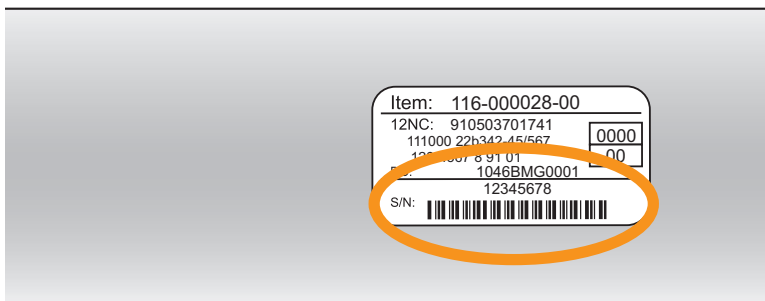
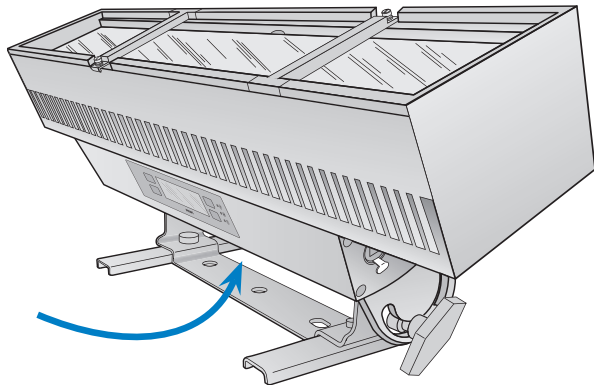

3. Assign each fixture to a position in the lighting design plan.
4. To streamline installation and aid in light show programming, you can affix a label identifying the order or placement in the installation to an inconspicuous location on each light fixture's housing.

## Maximum power run lengths

Voltage	Maximum Feet of ColorBlaze TRX Fixtures	Maximum Feet of Power Cables
100 VAC	8	100
120 VAC	12	100
208 VAC	20	200
220 VAC	22	175
230 VAC	22	200
240 VAC	24	200

Assumes fixtures installed in series on a 20 A circuit with 12 AWG power cables. Maximum number of fixtures can include any combination of 2 ft and 6 ft fixtures. Maximum feet of power cables = leader cable + jumper cables.

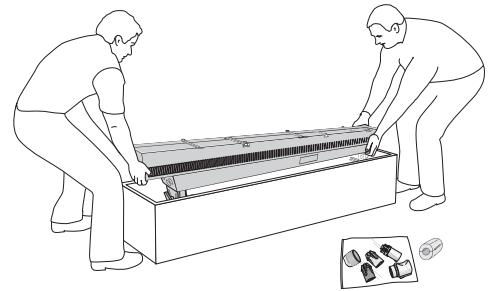

### Included in the box

- ColorBlaze TRX fixture
- Neutrik PowerCon connector
- Ferrite core for EMI suppression

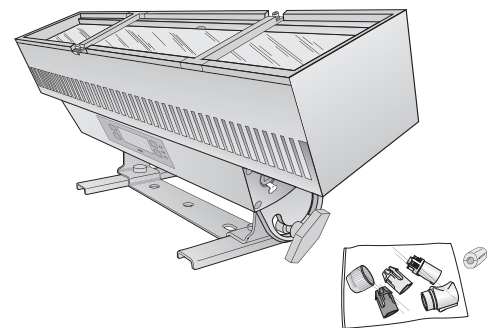

## Connect Fixture to Power

ColorBlaze TRX has integrated, auto-switching power supplies that automatically adjust to any 50 / 60 Hz power source from 100 – 240 V. ColorBlaze TRX fixtures connect directly to line power using the included Neutrik PowerCon connector and the appropriate length of power cable. We recommend using 3-conductor 12 AWG (3.3 mm<sup>2</sup>) stranded copper wire

1. Unpack the fixture, and place it in a staging area or other location where the power and data ports on the ends of the fixture are readily accessible.
2. Connect the appropriate length of 3-wire power cable from line power to the Neutrik PowerCon connector. Following the connector manufacturer's instructions, assemble the connector, connecting ground (earth), line, and neutral.

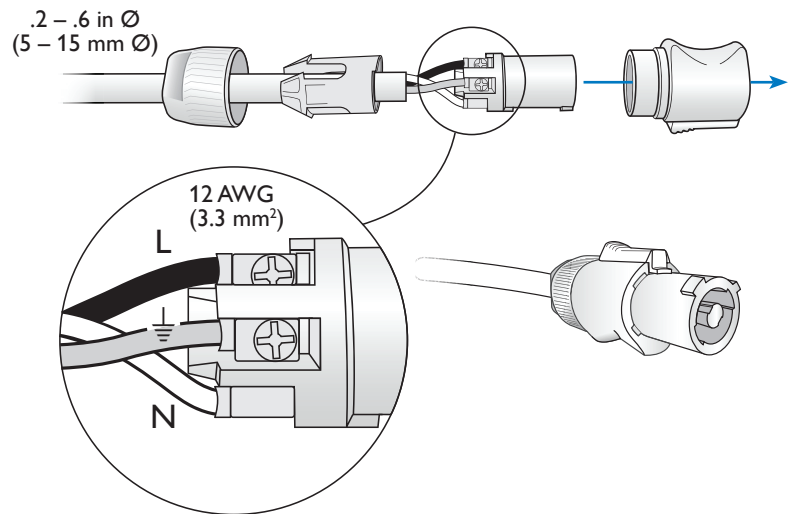

3. Insert the assembled power connector into the power input port on the input side of the fixture (with the onboard controls facing you, the left end of the fixture).

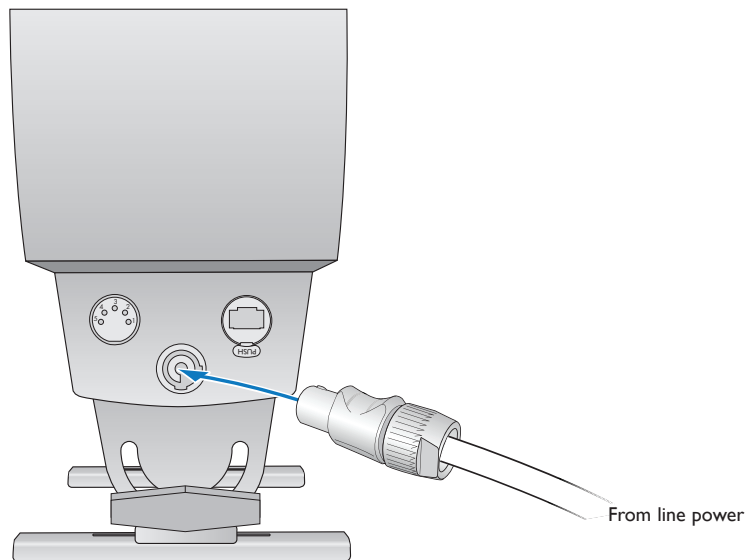

# Address and Configure the Fixtures

Make sure the power is ON before addressing and configuring fixtures.

When in DMX / Ethernet mode, each ColorBlaze TRX fixture uses a set of sequential DMX addresses. A ColorBlaze TRX fixture uses from 3 to 216 DMX addresses, depending on color control mode (3-channel or 5-channel DMX input), fixture resolution (8-bit or 16-bit), fixture length (2 ft or 6 ft), segment size (ranging from 4 in to the total fixture length), and whether the intensity channel is enabled or disabled.

In 8-bit mode, each segment uses one DMX address per channel, while in 16-bit mode each segment uses two DMX addresses per channel, one for coarse control and one for fine control. The coarse channel allows values in multiples of 256, while the fine channel adds 256 additional values to each coarse channel value, resulting in a total of 65,536 individual steps or settings (256 x 256). Channel assignments per segment are as follows:

## Channels Per Node

RGB in / out and RGB -> RGBAW (3-channel RGB input)							Intensity Channel Enabled	
8-Bit Mode	1		2		3		4	
	Red		Green		Blue		Intensity	
16-Bit Mode	1	2	3	4	5	6	7	8
	Red Coarse	Red Fine	Green Coarse	Green Fine	Blue Coarse	Blue Fine	Intensity Coarse	Intensity Fine

RGBAW in / out (5-channel RGBAW input)										Intensity Channel Enabled		
8-Bit Mode	1		2		3		4		5		6	
	Red		Green		Blue		Amber		White		Intensity	
16-Bit Mode	1	2	3	4	5	6	7	8	9	10	11	12
	Red Coarse	Red Fine	Green Coarse	Green Fine	Blue Coarse	Blue Fine	Amber Coarse	Amber Fine	White Coarse	White Fine	Intensity Coarse	Intensity Fine

Each ColorBlaze TRX fixture is factory-addressed with a DMX starting address of 1. Sequential DMX addresses are automatically assigned to the fixture beginning with the starting address. For instance, if you set a 2 ft fixture to RGB in / out mode, 8-bit operation, segment size of 24 in, and DMX starting address 73, the fixture is automatically assigned three DMX addresses, 73 – 75. If you set a 2 ft fixture to RGBAW in / out mode, 16-bit operation, segment size of 4 in, and DMX starting address 400, the fixture is automatically assigned 60 DMX addresses, 400 – 459.

Make sure that the DMX starting address allows enough DMX addresses for all of the fixture's segments, or the fixture will not function properly. For example, a 2 ft fixture with 4 in segments set to RGBAW in / out at 8-bit resolution requires 30 DMX addresses — 5 addresses per each of six segments. Therefore, the fixture's DMX starting address should be 483 or lower.

## Addressing in a DMX Lighting Network

Since each DMX universe is limited to 512 DMX addresses, you must take care to configure and address your fixtures to ensure that enough unique addresses are available to support your light show designs.

For lighting designs where fixtures work in unison, all fixtures can be assigned the same DMX starting address. For light show designs that display different output on different fixtures or segments simultaneously, you must address your fixtures such that the DMX addresses assigned to each segment are unique and do not overlap.

**\*** Terminology for individually controllable LED lighting units varies and can become confusing. In general, an individually controllable lighting unit is referred to as a node. A fixture can function as a single node, or it can contain multiple nodes. ColorBlaze TRX is unusual because it can be segmented into one or more nodes.

In video displays, individually controllable nodes are often referred to as pixels. A pixel can be a single-node fixture, or a segment of a multiple-node fixture.

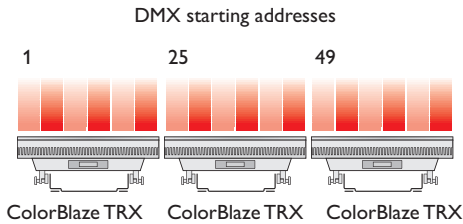

For example, in a series of three 2 ft fixtures, each with 4 in segments, RGB in / out, 8-bit resolution, and the intensity channel enabled, you can ensure that each fixture segment is uniquely addressed by setting the DMX starting address of the first fixture to 1, the starting address of the second fixture to 25 (1 + 24), and the starting address of the third fixture to 49 (25 + 24).

### Addressing in an Ethernet Lighting Network

Because it eliminates the addressing limitations of DMX, Ethernet is preferred for lighting installations that display intricate effects requiring hundreds or thousands of individually addressable nodes.

In Ethernet lighting networks, each fixture effectively functions as its own DMX universe. Ethernet lighting controllers identify each ColorBlaze TRX fixture by an IP address. As long as all ColorBlaze TRX IP addresses are unique within an installation, the set of DMX addresses assigned to a given fixture is unique within the installation, regardless of the fixture's DMX starting address.

### Some Notes About Fixture Segments

Each ColorBlaze TRX fixture is factory-addressed to have a segment size of 4 in (highest resolution) and a DMX starting address of 1. For complex installations where you set different numbers of groups on different fixtures, it's good practice to notate each fixture's group setting on the lighting design plan.

Keep the following considerations in mind when setting the number of fixture groups:

- You can mix 2 ft and 6 ft ColorBlaze TRX fixtures in the same series while maintaining consistent segment lengths of 4 in, 8 in, 12 in, or 24 in.

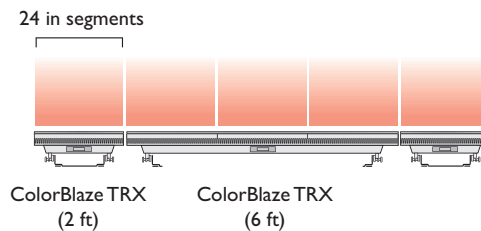

- If you install fixtures of the same length end to end, you can create virtual segments that span multiple fixtures. For example, you can create virtual 9 ft segments with 6 ft ColorBlaze TRX fixtures by alternating fixtures with 72 in and 36 in segment sizes.

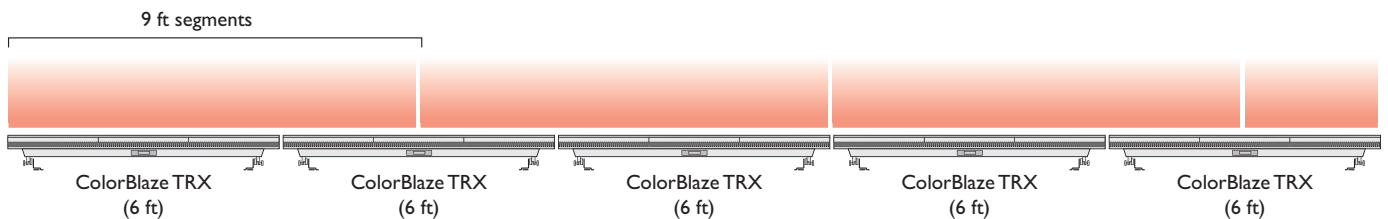

✳️ To streamline configuration and light show programming, note each fixture's IP address, if applicable, and the DMX starting address of each fixture segment, on your lighting design plan.

### Addressing and Configuration Methods

You can manually set the color control mode, fixture resolution, segment size, intensity channel setting, and DMX starting address of a ColorBlaze TRX fixture using the onboard menus. Refer to "Using the ColorBlaze TRX Onboard Menu," beginning on page 23, for details.

You can also remotely address and configure ColorBlaze TRX fixtures using QuickPlay Pro addressing and configuration software with a computer connected to your lighting network. Refer to "Addressing and Configuring ColorBlaze TRX with QuickPlay Pro" on page 37 for details.

## Using the Intensity Channel

Enabling the intensity channel lets you adjust the brightness of all LED channels proportionally using a fader on a DMX console. For example, you can set a desired color, then adjust the brightness with the assigned fader while maintaining the color value.

When you enable the intensity channel, each ColorBlaze TRX node consumes an additional DMX address in 8-bit mode and two additional DMX addresses in 16-bit mode (as shown in the table on page 12). Make sure that your addressing scheme accounts for the additional DMX addresses that the intensity channel requires.

You can use the Single-Channel Fixture icon in ColorPlay 3 (version 1.10 and higher) to represent and control the intensity channel in a ColorPlay 3 light show. Refer to the ColorPlay 3 *User Guide* for more information.

✳ For instructions on enabling and disabling the intensity channel, refer to "Enabling and Disabling the Intensity Channel" on page 31.

## Options for Controlling ColorBlaze TRX Fixtures

In addition to standard control schemes using DMX- or Ethernet-based lighting consoles and controllers, ColorBlaze TRX offers a number of control options designed to support architectural, theatrical, and portable lighting applications.

### Standalone Mode

By default, the input source of a ColorBlaze TRX fixture is DMX / Ethernet. When in DMX / Ethernet mode, ColorBlaze TRX listens for and responds to DMX or Ethernet data transmitted to the lighting network by a console or controller.

You can change the input source of ColorBlaze TRX fixture to Standalone. In Standalone mode, a ColorBlaze TRX fixture ignores DMX and Ethernet data input and displays either a pre-set show or a ColorPlay 3 show stored on the fixture's SD card. ColorBlaze TRX offers three pre-set shows — Fixed Color, Color Wash, and Chasing Rainbow — which you can configure using the fixture's on-board menus.

You can download light shows and triggers onto a fixture's installed SD card from ColorPlay 3, light show authoring and configuration software from Philips Color Kinetics. ColorPlay 3 is bundled with the iPlayer 3 DMX controller, and is also available as a free download from the Philips Color Kinetics website.

To download ColorPlay 3 light shows and triggers to the ColorBlaze TRX SD card, you connect a computer running ColorPlay 3 to an Ethernet switch in the lighting network, or directly to the Ethernet input on a ColorBlaze TRX fixture, using a standard CAT-5e or better cable. An iPlayer 3 controller is not required.

✳ You can download the latest version of ColorPlay 3 from [www.colorkinetics.com/support/iplayer3/](http://www.colorkinetics.com/support/iplayer3/)

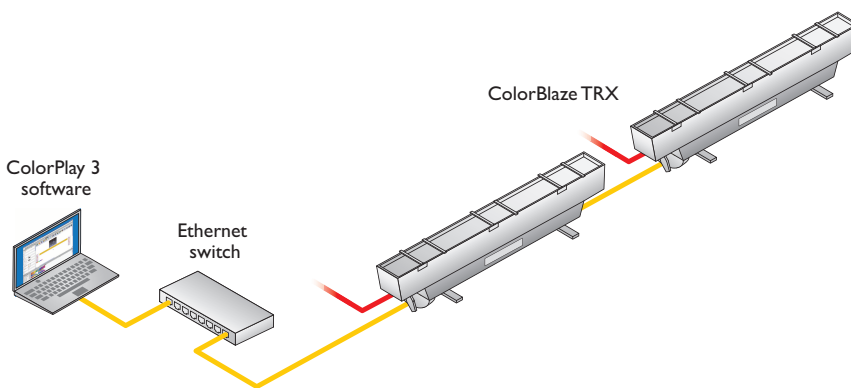

✳ For instructions on setting fixture input source, configuring pre-set shows, and playing triggers and shows from the fixture's SD card, refer to "Using the ColorBlaze TRX Onboard Menus," beginning on page 23.

You can download up to 255 triggers to the ColorBlaze TRX SD card. You can download as many ColorPlay 3 light shows as the SD card can contain, but only the 255 most recently downloaded shows appear on the ColorBlaze TRX menu.

✳️ You can download the ColorPlay 3 User Guide from [www.philipscolorkinetics.com/ls/controllers/lplayer3/](http://www.philipscolorkinetics.com/ls/controllers/lplayer3/)

Commands on the on-board menus let you trigger shows or play show files directly from the SD card. For complete details on authoring ColorPlay 3 light shows, configuring triggers, and downloading shows and triggers, refer to the ColorPlay 3 User Guide.

### Master / Slave Mode

By default, ColorBlaze TRX fixtures are in Slave mode — that is, they respond to DMX or Ethernet data in the network (unless they are also in Standalone mode). You can configure a ColorBlaze TRX fixture to act as a master controller for ColorBlaze TRX fixtures that follow it in a run by putting the fixture in Master mode. When connected together properly, you can configure slave fixtures that follow the master fixture in a run to show the same output as the master fixture — a show playing from the master fixture's SD card, for example, or light output from a controller or lighting console connected to the master fixture.

Keep the following considerations in mind when using master / slave mode:

- Each run of ColorBlaze TRX fixtures can contain only one fixture in Master mode. All other fixtures in the run must be in Slave mode.
- The master ColorBlaze TRX fixture can send either DMX or Ethernet (KiNET) data to downstream slave fixtures. When sending DMX, fixtures must be connected together using XLR-5 cables and the fixtures' DMX input and output ports. When sending Ethernet, fixtures must be connected together using CAT-5e or better cables and the fixtures' Ethernet input and output ports.
- To listen to the DMX or KiNET output from the master fixture, the input source of downstream slave fixtures must be set to DMX / Ethernet. Downstream fixtures set to Standalone do not respond to the master fixture, but instead play their currently configured standalone effect or light show.

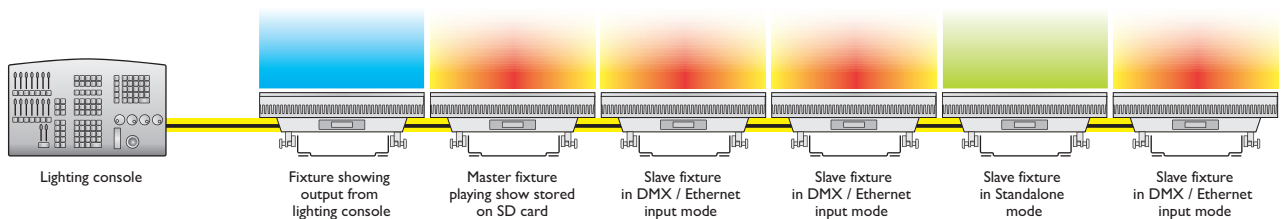

- For consistent results, make sure that all master and slave fixtures in a run are configured alike, with the same color control mode, bit depth, segment size, segment order, dimming curve, transition speed, and so on.
- You can connect a Philips Color Kinetics devices that accept Ethernet input — such as sPDS-480ca 24V power / data supplies, Data Enabler Pro devices, or iColor Accent MX Powercore fixtures — to the end of the run. When configured properly, the master ColorBlaze TRX fixture acts as a controller for these devices as well, allowing you to add other fixture types to a run.

✳️ In master mode, ColorBlaze TRX broadcasts one DMX universe of data. All ports on a multi-port power / data supply receive the same data.

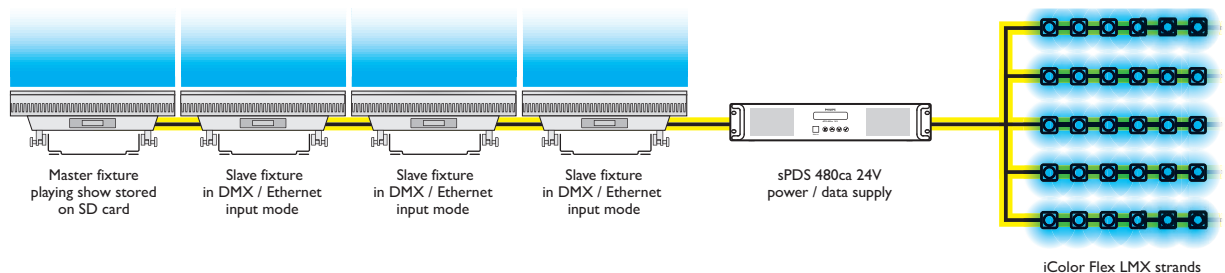

## Controlling ColorBlaze TRX Effects and Shows with Ethernet Controller Keypad

Ethernet Controller Keypad is a wall-mounted keypad from Philips Color Kinetics that triggers up to eight light shows at the touch of a button. When used in conjunction with ColorBlaze TRX, Ethernet Controller Keypad can provide push-button control of the first eight ColorPlay 3 triggers stored on the fixture's SD card.

In architectural and portable installations consisting of multiple ColorBlaze TRX fixtures, we recommend using Ethernet Controller Keypad in conjunction with master / slave mode to ensure that fixtures work in unison. If you trigger the same set of shows from the individual SD cards of fixture's in a run, the fixtures can fall out of synch with each other, especially when displaying lengthy shows.

To use Ethernet Controller Keypad with ColorBlaze TRX, configure master and slave fixtures in a run as described on the previous page. Connect Ethernet Controller Keypad to a Power-over-Ethernet port on an Ethernet switch, then connect the master fixture to another port on the switch.

\* For detailed product information, refer to the Ethernet Controller Keypad Product Guide at [www.philipscolorkinetics.com/ls/controllers/enetkeypad/](http://www.philipscolorkinetics.com/ls/controllers/enetkeypad/)

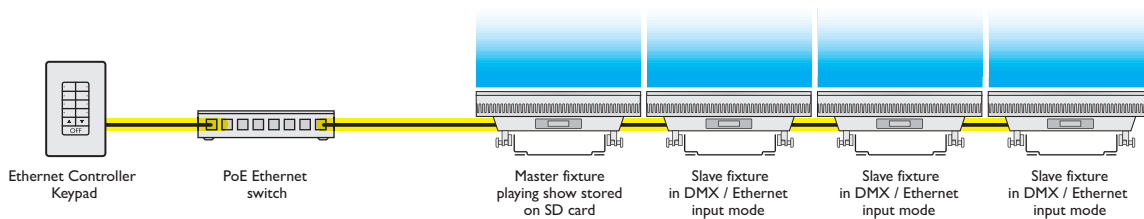

As shown below, buttons 1 – 8 on the Ethernet Controller Keypad activate triggers 1 – 8 stored on a ColorBlaze TRX fixture's SD card. If the fixture is currently playing a pre-set show, pressing buttons 1 – 8 stops the pre-set show and activates the trigger associated with the pressed button. The dimmer and OFF buttons work with both pre-set shows and triggers stored on the SD card.

### Ethernet Controller Keypad buttons

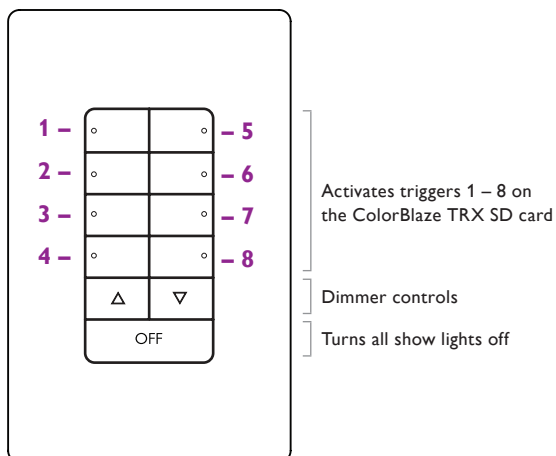

\* For instructions on how to configure ColorBlaze TRX fixtures, shows, and triggers in Standalone mode, refer to "Using the ColorBlaze TRX Onboard Menus," beginning on page 23.



## Using DMX Triggers

You can enable a DMX trigger to implement convenient playback of stored shows from a lighting console.

To enable a DMX trigger on a ColorBlaze TRX fixture, you assign an unused DMX address to serve as the trigger channel. Then you assign that DMX address to a channel on your lighting console and control the value — usually on a scale of 1% – 100% or 0 – 255. The DMX trigger divides the scale of values into 11 regions. The lowest region of the scale deactivates the trigger, while the other 10 regions activate the first 10 triggers stored on the fixture's SD card.

✳ For instructions on configuring DMX triggers, refer to "Configuring DMX Triggers" on page 32.

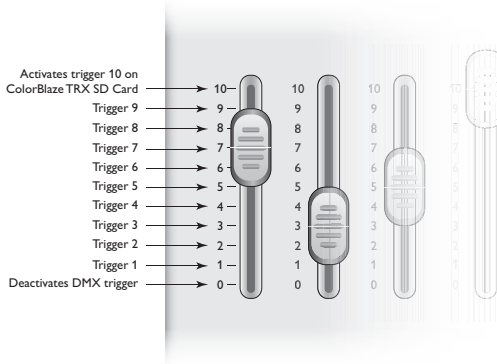

You can also assign the DMX trigger to a lighting console's fader. Fader positions 1 through 10 activate stored triggers 1 through 10, while fader position 0 deactivates the trigger.

## DMX Trigger Behavior

Action	0% – 100% Scale	0 – 255 Scale
Deactivate trigger	0% – 9%	0 – 23
Activate trigger 1	10% – 18%	24 – 46
Activate trigger 2	19% – 28%	47 – 69
Activate trigger 3	29% – 36%	70 – 93
Activate trigger 4	37% – 45%	94 – 116
Activate trigger 5	46% – 54%	117 – 139
Activate trigger 6	55% – 63%	140 – 162
Activate trigger 7	64% – 72%	163 – 186
Activate trigger 8	73% – 81%	187 – 209
Activate trigger 9	82% – 90%	210 – 232
Activate trigger 10	91% – 100%	233 – 255

Using a DMX trigger in conjunction with master / slave mode is a convenient way to show the same light output on multiple fixtures within the control network. Set a DMX trigger on the master fixture, and all properly configured slave fixtures respond in unison when the lighting console fader activates a show.

If you're not using master / slave mode, you can configure multiple ColorBlaze TRX fixtures to respond simultaneously by assigning the same DMX trigger to multiple ColorBlaze TRX fixtures in the network. Each fixture plays the set of shows stored on its own SD card.

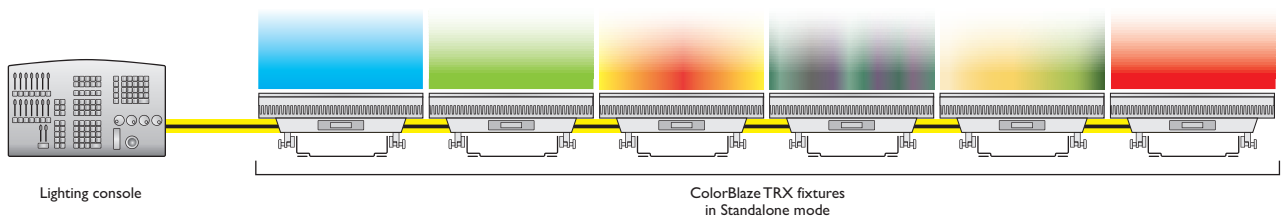

If you want all triggered fixtures to show the same light output, all SD cards must contain the same shows, 1 through 10. Note that if you trigger the same set of shows from the individual SD cards of multiple ColorBlaze TRX fixtures in a run, the fixtures can fall out of synch with each other, especially when displaying lengthy shows. To ensure consistent results, we recommend using a DMX trigger in conjunction with master / slave mode.

## Install Spread Lenses (Optional)

Spread lenses of 22°, 32°, 60°x 32°, or 32° x 12° rest in the ColorBlaze TRX lens rails, and are held in place by lens clips integrated into the fixture housing. Spread lenses are available in 2 ft sections, and can be laid end-to-end for full coverage in 6 ft fixtures.

1. Using fingers or a flathead screwdriver, loosen captive screws on lens clips and lift out of the way.

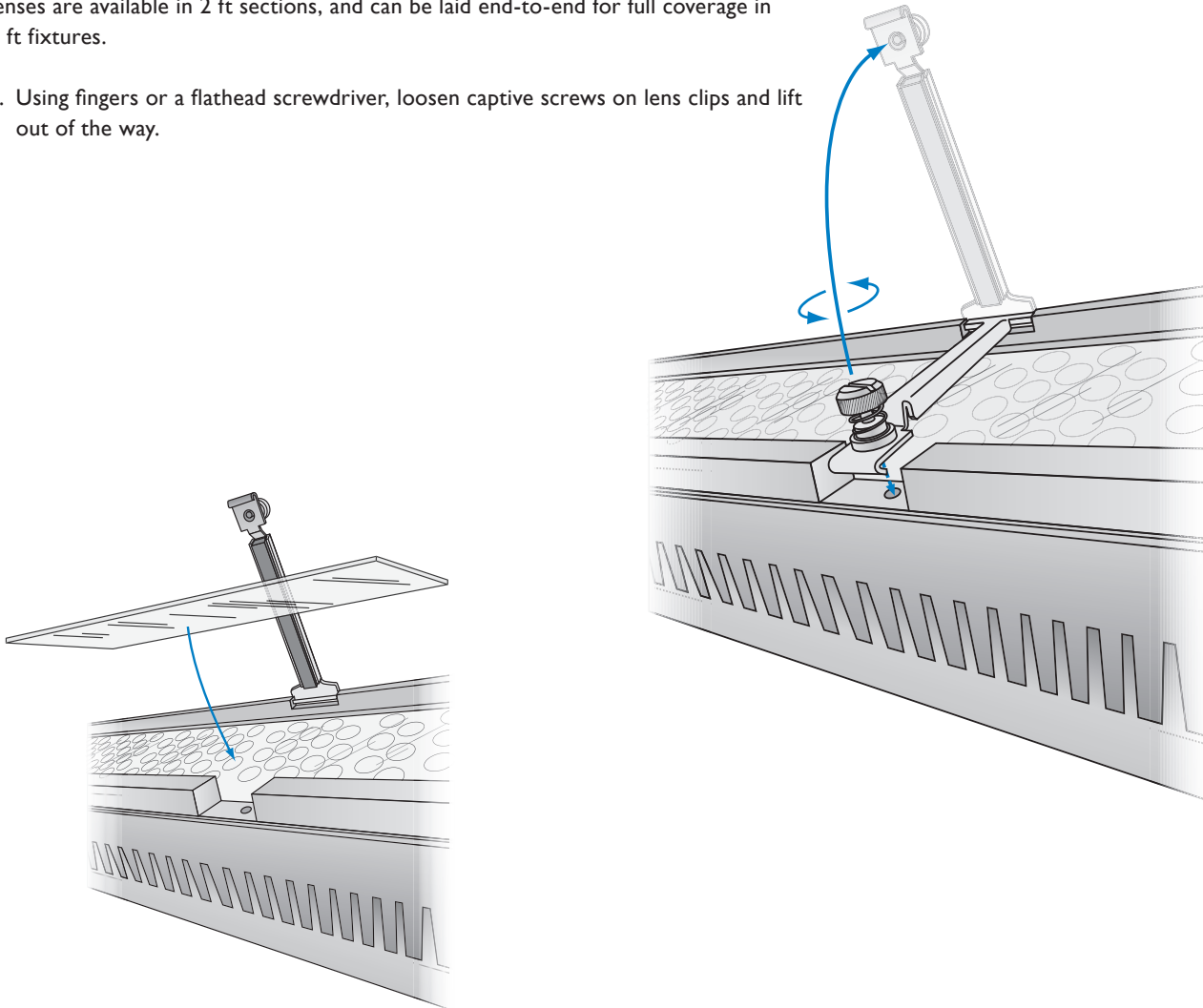

2. Rest lens or lenses in lens rail.

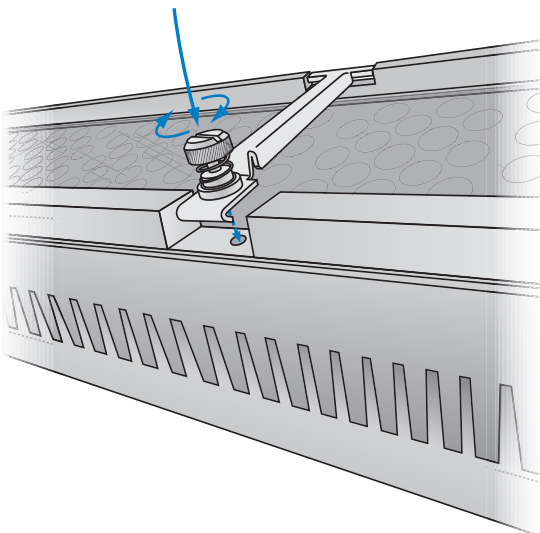

3. Fold lens clips back into position, and secure using fingers or a flathead screwdriver.

## Start the Installation

1. Verify that all supporting equipment (switches, controllers) is in place.
2. Ensure that all additional parts and tools are available, including:
  - Power cable using included PowerCon connector
  - If installing in series, a sufficient number and length of XLR-5, Ethercon, or RJ45 cable for data connections
  - If installing in series, a sufficient length of 3-wire cable for power, and a sufficient number of Neutrik PowerCon locking 3-pole power connectors, Use Neutrik NAC3FCA Power Connector Type A (blue connector) for power input, and Neutrik NAC3FCB Power Connector Type B (gray connector) for power output. We recommend 12 AWG (3.3 mm<sup>2</sup>) stranded copper wire.
  - If installing in series in a DMX network, a DMX terminator
  - C-clamps, bases, or other hardware for pipe, truss, or floor mounting, as needed

\* We recommend using 22 AWG 5-pin XLR shielded cable with all five pins wired.

## Mount Fixtures

ColorBlaze TRX fixtures come with an attached mounting trunion or mounting feet designed for 1/2 in mounting hardware. Fixtures can be mounted to a surface or to a pipe or truss with standard pipe clamps or Cheeseborough clamps.

Ensure that the installation is suitable and safe and that the hardware is properly rated for the task. When mounting ColorBlaze TRX fixtures on the floor or a base, also ensure that the fixture sits flush to the surface.

The three holes in each foot of the 6 ft fixture, and in the mounting trunion of the 2 ft fixture, provide a clearance for a 1/2 in bolt for mounting to a pipe, truss, weighted base, or floor using a standard theatrical C-clamp or other mounting hardware.

\* Because 6 ft ColorBlaze TRX fixtures are bulky and weigh 43 lb (19.5 kg), you may need two people to position and install each fixture in its mounting location.

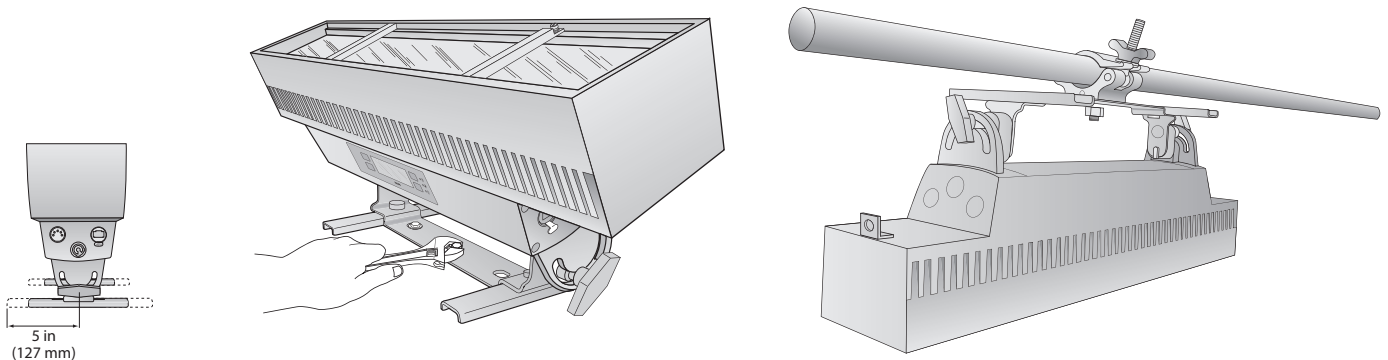

\* When a fixture is hung upside down or is hard to access, you can flip the orientation of the menu display so that it appears right side up to the operator. Refer to page 23 for details.

## Attach Safety Cables (Optional)

Each ColorBlaze TRX fixture is designed for use with safety cables to tether fixtures to secure anchor points. When suspending or installing ColorBlaze TRX fixtures overhead, or when dictated by local or state code or advised by a structural engineer, loop safety cables through the restraining holes located at the either end of the ColorBlaze TRX housing. Securely anchor the safety cables using a method that follows code or engineer's requirements.

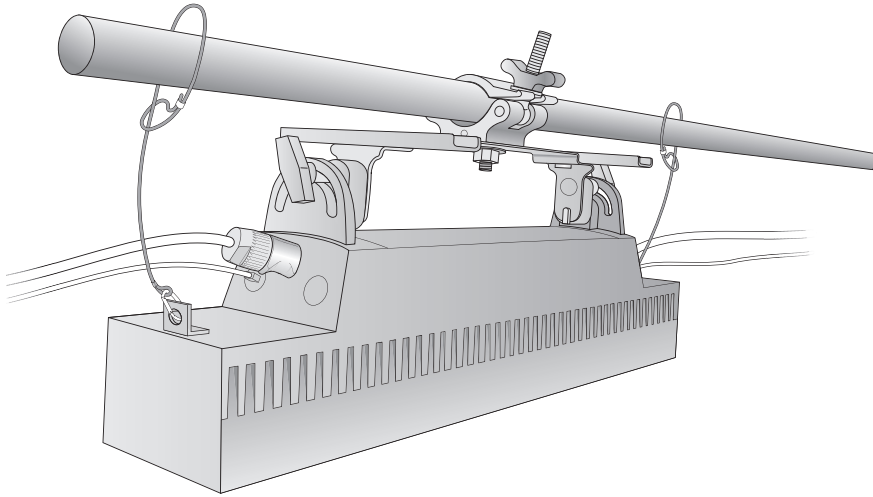

### Safety cable minimum requirements

Material	316 Stainless Steel
Size	5/64 to 3/16 in (2 to 5 mm) nominal diameter. Minimum break load must be greater than 400 lb (181 kg)
Construction	7 x 7 (49 wires) preformed stranded

## Connect Data and Power

Make sure the power is OFF before connecting ColorBlaze TRX fixtures.

1. Supply power to the first ColorBlaze TRX fixture in a series by plugging a power cable with Neutrik PowerCon connector into the blue Power In port on the input side of the fixture.

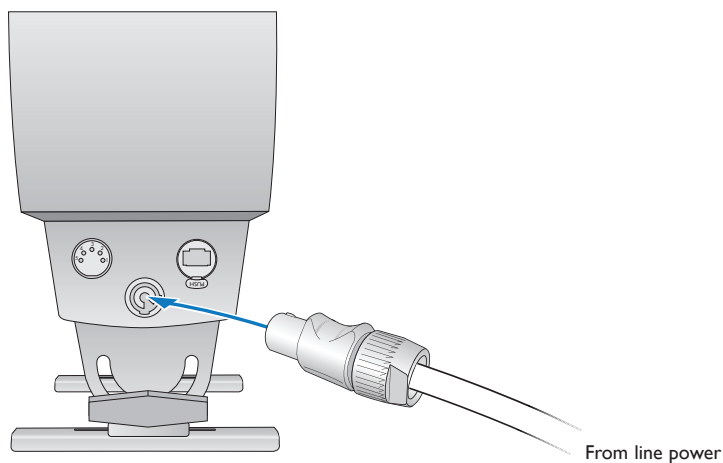

\* We recommend using 22 AWG 5-pin XLR shielded cable with all five pins wired.

2. Using a standard RJ45 or Ethercon cable for Ethernet, or XLR-5 data cable for DMX, connect data directly from an Ethernet or DMX controller's data output port to a data input port on the first ColorBlaze TRX fixture in a series.

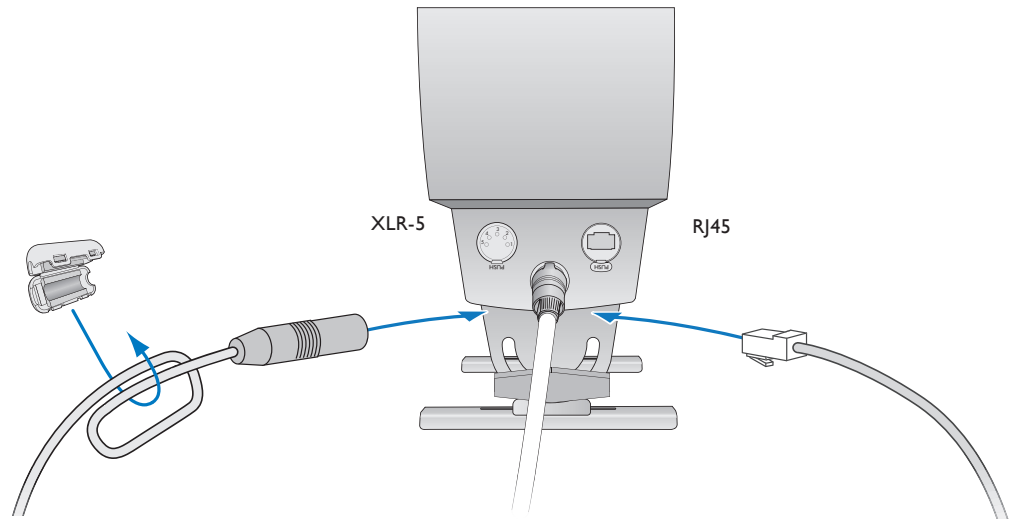

\* For EMI suppression, loop each XLR-5 cable and snap the included ferrite core onto the cable as close as possible to the fixture's data input port.

3. If connecting in series for data, connect a data output port on the first fixture to a data input port on the next fixture in sequence, using a standard RJ45, Ethercon, or XLR-5 data cable.
4. If connecting in series for power, connect the power output port on the first fixture to the power input port on the next fixture using a power cable with a gray Neutrik NAC3FCB Power Connector Type B on one end and a blue Neutrik NAC3FCA Power Connector Type A on the other end.

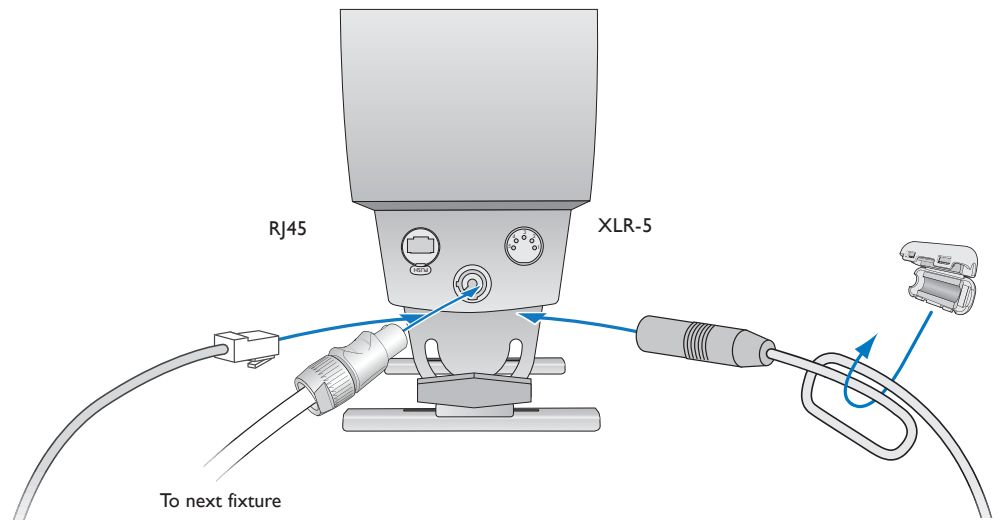

4. If connecting in series, repeat steps 3 and 4, as needed, for each ColorBlaze TRX fixture in the series.

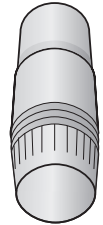
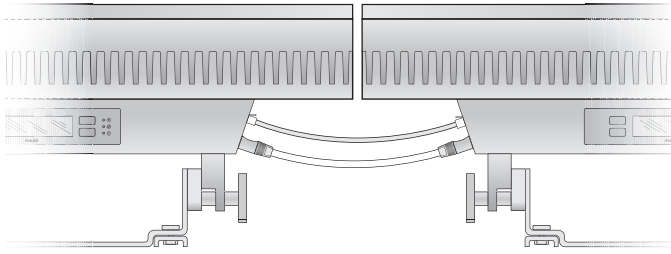

5. In a DMX network, insert a standard data terminator in a data output port on the last fixture in the series.

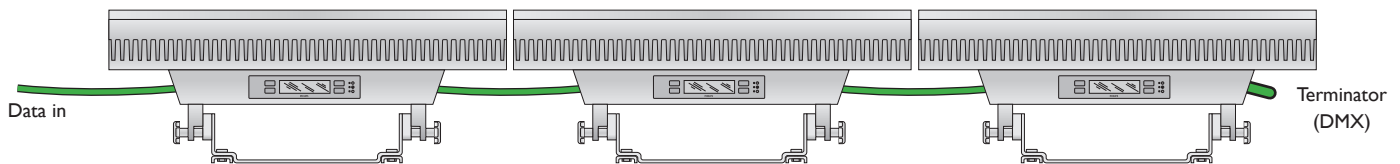

## Rotate and Aim Fixtures

Make sure the power is ON before rotating and aiming ColorBlaze TRX fixtures. Be careful not to look directly into the beam.

1. Loosen the locking knobs at each end of a ColorBlaze TRX fixture to allow the fixture to rotate freely through 165°.
2. Rotate the fixture to the desired position.
3. Hand-tighten the locking knobs.

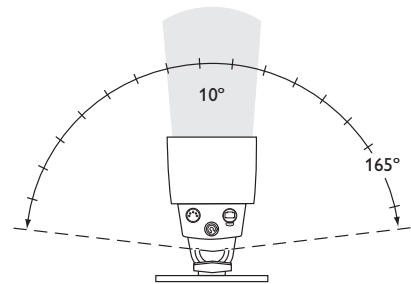

**⚠** Do not look directly into the fixture when aiming and locking.

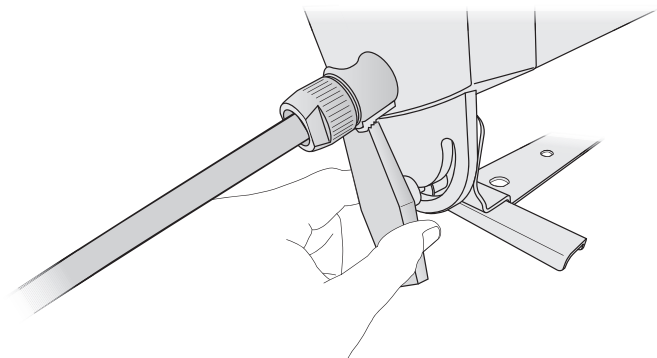

# Using the ColorBlaze TRX Onboard Menus

ColorBlaze TRX offers extensive onboard menus that give you fingertip control of all of the fixture's functions. Functions include the ability to:

- Put the fixture in Standalone mode and choose from configurable pre-set shows or custom shows stored on the installed SD card
- Set the fixture's starting DMX address, segment size and order, resolution, intensity channel, dimming curve, LED transition speed, color control mode, and IP address
- Put the fixture in Master / Slave mode and set the master fixture's output mode
- Flip the menu display for convenience when hanging the fixture upside-down, and set menu display and lock timeouts
- Test the LED channels, user interface, fan speeds, and operating temperatures
- Display version information, such as installed firmware versions, serial numbers of internal hardware, current ambient and board temperatures, and fan speeds

## Overview of the Onboard Menus

The ColorBlaze TRX onboard menus appear in a control panel on the front of the fixture, with the fixture's input side to the left and the output side to the right. The control panel displays menu option names, icons indicating current button behavior, and fixture configuration and status information.

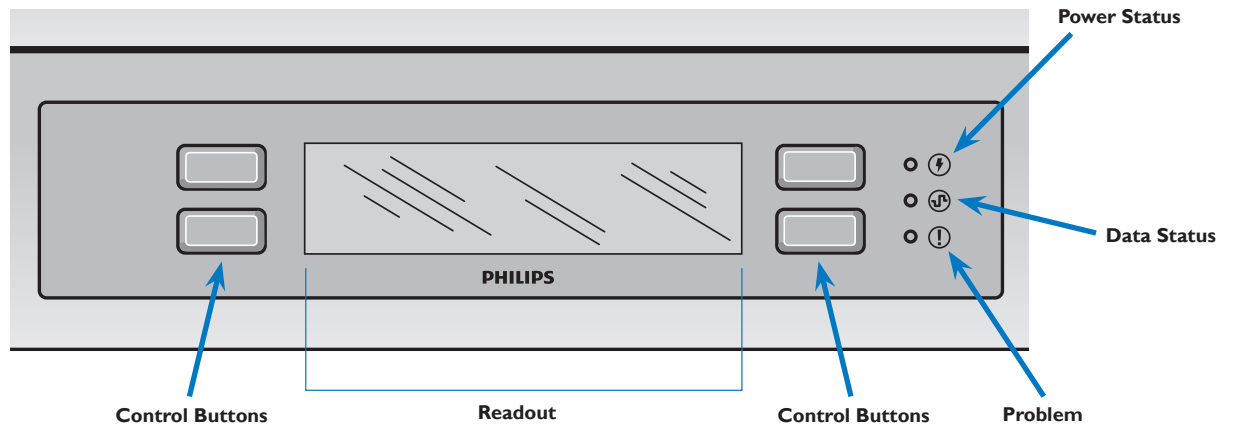

You can navigate the menus and make selections using four rubberized control buttons, the behavior of which can change depending on context and menu orientation (normal or flipped). In general, when the menus are unlocked, the buttons behave as follows:

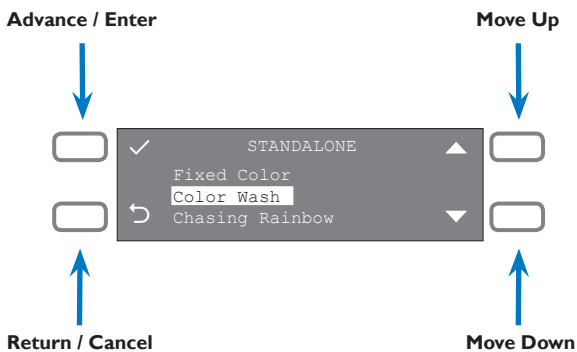

- Advance / Enter advances to the next menu (moves down one level in the menu tree), or confirms a selection
- Return / Cancel returns to the previous menu (moves up one level in the menu tree) or cancels a selection
- Up moves up in the current menu's set of options
- Down moves down in the current menu's set of options

# ColorBlaze TRX On-Board Menus

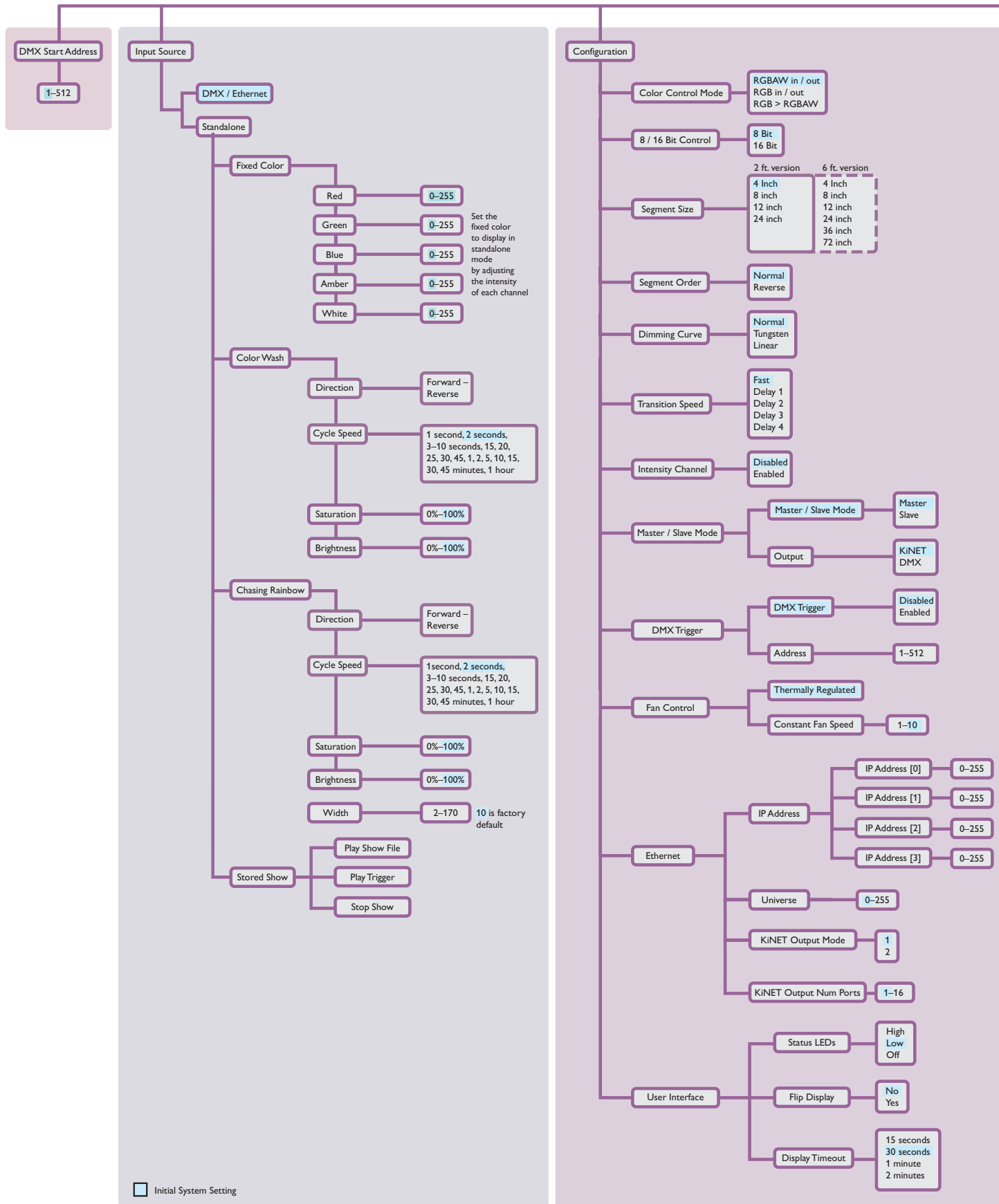



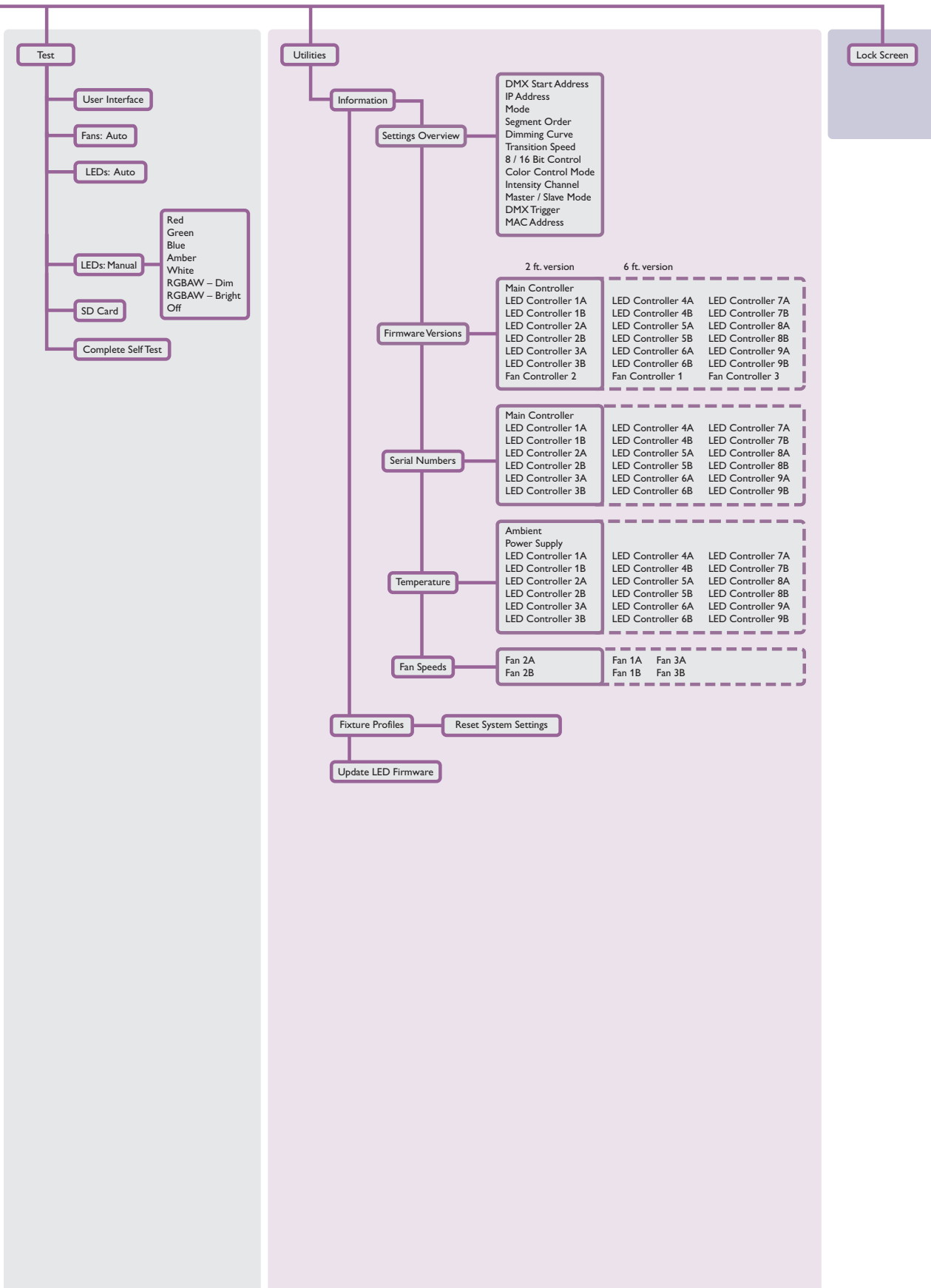

## Locking and Unlocking Menus

The ColorBlaze TRX onboard menus time out and lock after a period of inactivity. When the menus are locked and a button is pressed, the control panel displays a Locked icon and information about the fixture's current mode. If the fixture is in DMX / Ethernet mode, the control panel displays the starting DMX address. If in Standalone mode, the readout displays the name of the currently selected pre-set show.

Without unlocking the menus, you can press the Settings button to display settings overview information, or press and hold the Flip button to flip the menu display in cases where a fixture is hung upside down.

### ► To unlock the ColorBlaze TRX menus:

- Press and hold the Unlock button for approximately three seconds.

#### Settings Overview



### ► To set the ColorBlaze TRX display timeout:

1. Select Configuration > User Interface > Display Timeout.
2. Select a display timeout of 15 seconds, 30 seconds, 1 minute, or 2 minutes.

### ► To manually lock the ColorBlaze TRX menus:

- Select Lock Screen from the main menu.

## Displaying and Setting Fixture Mode

ColorBlaze TRX can work in either DMX / Ethernet mode or Standalone mode. When in DMX / Ethernet mode, ColorBlaze TRX responds to data input from a DMX or Ethernet controller. In Standalone mode, ColorBlaze TRX ignores any data input and displays a pre-set show, such as Fixed Color, Color Wash, or Chasing Rainbow. You can configure various properties of the shows, as described on pages 23 – 24.

### ► To display the fixture's current mode, do one of the following:

- With the menus locked, press any button. If in DMX / Ethernet mode, the readout displays the starting DMX start address (1 – 512). If in standalone mode, the readout displays the name of the selected pre-set show.
- Select Utilities > Information > Settings Overview. The Mode entry displays either DMX / Ethernet or Standalone.

*\* You can also display Settings Overview when the menus are locked by pressing the button next to the Settings icon.*

### ► To put a fixture in DMX / Ethernet mode:

- Select Input Source > DMX / Ethernet.

### ► To put a fixture in Standalone mode:

- Select Input Source > Standalone, then select a pre-set show. You can configure the show's properties, as described in "Configuring Pre-Set Show Properties" below.

## Displaying and Setting the DMX Start Address

By default, the DMX start address of a ColorBlaze TRX fixture is 1. ColorBlaze TRX uses a set of consecutive DMX addresses, beginning with the DMX start address.

A ColorBlaze TRX fixture uses from 3 to 216 DMX channels, depending on color control mode (3-channel or 5-channel DMX input), fixture resolution (8-bit or 16-bit), fixture length (2 ft or 6 ft), whether the intensity channel is enabled or disabled, and segment size, which can range from 4 in to the total fixture length.

Make sure that the DMX start address allows enough DMX addresses for all of the fixture's segments, or the fixture will not function properly. For example, a 2 ft fixture with 4 in segments set to normal color control mode (RGBAW in / out) at 8-bit resolution requires 30 DMX addresses — 5 addresses per each of six segments. Therefore, the fixture's DMX start address should be 483 or lower.

### ► To display the DMX start address currently assigned to a fixture:

- With the menus locked, press any button. If in DMX / Ethernet mode, the readout displays the fixture's DMX start address.
- Select Utilities > Information > Settings Overview. The DMX Start Address entry displays the fixture's DMX Start address.

### ► To set a fixture's DMX start address:

1. Select DMX Start Address from the main menu.
2. Select a DMX start address (1 – 512).
3. Press Enter to confirm your selection.

## Configuring Pre-Set Show Properties

When you put a ColorBlaze TRX fixture in Standalone mode, it ignores any data input and displays a selected pre-set show. You can configure the properties of each pre-set show to produce a desired effect.

### Fixed Color

Fixed Color displays a single solid color. You select the color by adjusting the intensity of each LED channel. By default, the intensity of each channel is 0 (the fixture displays black output).

### ► To configure Fixed Color properties:

1. Select Input Source > Standalone > Fixed Color.
2. Select the Red, Green, Blue, Amber, or White channel, then select an intensity for the channel (0 – 255).
3. Repeat step 2 for each channel that you want to set.

### Color Wash

The Color Wash effect creates a smooth transition through a series of solid colors on all fixtures simultaneously.

### ► To configure Color Wash properties:

1. Select Input Source > Standalone > Color Wash.
2. Set Color Wash properties:
  - Direction is the order in which the effect transitions through the sequence of colors. Forward (the default) progresses from red through yellow, green, blue, and back to red. Reverse progresses from red through blue, green, yellow, and back to red.

 When playing the Fixed Color show on a master fixture, the slave fixtures must be in 8-bit RGBAW in / out mode.

Select Direction, then select Forward or Reverse. Press Enter to confirm your selection.

- Cycle Speed is the transition time, from 1 second to 1 hour, between colors in the effect.

Select Cycle Speed, then a transition time. Press Enter to confirm your selection.

- Saturation is the maximum colorfulness of each color in the sequence. Transitions fade colors in from 0% colorfulness to the Saturation setting. Setting Saturation to 100% produces the greatest color variation, while setting the saturation to 0% produces no color variation.

Select Saturation, then select a saturation from 0% to 100%. Press Enter to confirm your selection.

- Brightness is the overall brightness of the effect. Setting the brightness to 100% produces the maximum light output, while setting the brightness to 0% produces no light output (fixture is black).

Select Brightness, then select a brightness from 0% to 100%. Press Enter to confirm your selection.

## Chasing Rainbow

Chasing Rainbow creates bars of repeated color moving or “chasing” each other from node to node in one direction.

### ► To configure Chasing Rainbow properties:

1. Select Input Source > Standalone > Chasing Rainbow.

2. Set Chasing Rainbow properties:

- Direction is apparent direction in which the color bars move. Forward (the default) moves from the fixture's input side to its output side. Reverse moves from the output side to the input side.

Select Direction, then select Forward or Reverse. Press Enter to confirm your selection.

- Cycle Speed is how long it takes, from 1 second to 1 hour, to cycle through the color sequence.

Select Cycle Speed, then a cycle time. Press Enter to confirm your selection.

- Saturation is the maximum colorfulness of each color in the sequence. Transitions fade colors in from 0% colorfulness to the Saturation setting. Setting Saturation to 100% produces the greatest color variation, while setting the saturation to 0% produces no color variation.

Select Saturation, then select a saturation from 0% to 100%. Press Enter to confirm your selection.

- Brightness is the overall brightness of the effect. Setting the brightness to 100% produces the maximum light output, while setting the brightness to 0% produces no light output (fixture is black).

Select Brightness, then select a brightness from 0% to 100%. Press Enter to confirm your selection.

- Width is the number of pixels (nodes) that the effect uses (10 pixels by default). If a fixture has fewer nodes than the effect width, only a portion of the effect will be visible at a time. If a fixture has more nodes than the effect width, the effect will "tile" or repeat.

Select Width, then select the pixel width for the effect, from 1 to 170. Press Enter to confirm your selection.

 When playing the Color Wash or Chasing Rainbow show on a master fixture, the slave fixtures must be in 8-bit RGB in / out or RGB -> RGBAW mode, and they must be addressed properly .

 Setting the Chasing Rainbow effect width to 1 pixel effectively produces a Color Wash effect, since all nodes act in unison.

\* For complete details on authoring ColorPlay 3 light shows, configuring triggers, and downloading shows and triggers, refer to the ColorPlay 3 User Guide, available at [www.philipscolorkinetics.com/lis/controllers/iplayer3/](http://www.philipscolorkinetics.com/lis/controllers/iplayer3/)

\* For proper playback, make sure that the configuration of ColorBlaze TRX fixtures matches the settings of the ColorPlay 3 show.

\* You can use Ethernet Controller Keypad to play triggers 1 – 8, and to control the brightness of lights in Standalone mode. Refer to "Controlling Effects and Shows with Ethernet Controller Keypad" on page 16 for more information.

## Storing and Playing ColorPlay 3 Shows and Triggers

ColorBlaze TRX contains an installed SD card to which you can download light shows and triggers from ColorPlay 3, light show authoring and configuration software from Philips Color Kinetics. Commands on the Input Source > Standalone > Stored Show menu let you trigger shows or play show files directly from the SD card.

### ► To trigger a show stored on the SD card:

1. Select Input Source > Standalone > Stored Show > Play Trigger.
2. Select the trigger you want to play.
3. Press Enter to confirm your selection.

### ► To play a show stored on the SD card:

1. Select Input Source > Standalone > Stored Show > Play Show File.
2. Select the show file you want to play.
3. Press Enter to confirm your selection.

### ► To stop show playing from the SD card and display black:

- Select Input Source > Standalone > Stored Show > Stop Show.

## Setting Color Control Mode

ColorBlaze TRX offers three color control modes:

**RGBAW in / out** ColorBlaze TRX accepts five channels of DMX data, and outputs to five channels of LEDs (red, green, blue, amber, and white)

**RGB in / out** ColorBlaze TRX accepts three channels of DMX data (red, green, and blue), and outputs to three channels of LEDs (the amber and white channels are not used)

**RGB -> RGBAW** ColorBlaze TRX accepts three channels of DMX data (red, green, and blue), and maps the input to five channels of LEDs (red, green, blue, amber, and white)

### ► To set a fixture's color control mode:

1. Select Configuration > Color Control Mode.
2. Select RGBAW in/out, RGB in/out, or RGB->RGBAW.
3. Press Enter to confirm your selection.

## Setting Fixture Resolution

ColorBlaze TRX can function in 8-bit or 16-bit mode. 16-bit mode affords finer control over brightness and color selection, but requires a 16-bit DMX controller. In 16-bit mode, each fixture segment consumes twice as many consecutive DMX channels.

### ► To set a fixture's resolution:

1. Select Configuration > 8 / 16 Bit Control.
2. Select 8 bit or 16 bit.
3. Press Enter to confirm your selection.

## Setting Segment Size and Segment Order

ColorBlaze TRX fixtures have variable segment sizes, ranging from 4 in to the total fixture length (24 in or 72 in). Each segment functions as a separate, individually controllable node or pixel. Increasing the number of segments increases the number of consecutive DMX addresses that a fixture consumes.

### Number of DMX Channels Per Segment

Color Control Mode	8-Bit Resolution		16-Bit Resolution	
	Intensity Channel Off	Intensity Channel On	Intensity Channel Off	Intensity Channel On
RGBAW in / out	5	6	10	12
RGB in / out	3	4	6	8
RGB -> RGBAW	3	4	6	8

Segment order is important for dynamic effects that move, chase, or sweep across the nodes in a fixture or set of fixtures. Normal segment order is from input side to output side (left to right facing the front of the fixture). Reverse segment order is from output side to input side (right to left).

#### ► To set segment size:

1. Select Configuration > Segment Size.
2. Select a segment size of 4 in, 8 in, 12 in, 24 in, 36 in (6 ft fixture only), or 72 in (6 ft fixture only).
3. Press Enter to confirm your selection.

#### ► To set segment order:

1. Select Configuration > Segment Order.
2. Select Normal or Reverse.
3. Press Enter to confirm your selection.

## Setting Fixture Dimming Curve

Dimming curves describe how slowly or quickly a fixture dims at different levels of input. For finer control, ColorBlaze TRX offers three different dimming curves for use in different situations and applications:

**Normal** The non-linear (gamma) dimming curve used in most Philips Color Kinetics LED lighting fixtures. Use this dimming curve to achieve consistent dimming behavior in an installation where ColorBlaze TRX is installed alongside other Philips Color Kinetics lighting fixtures.

**Tungsten** A non-linear dimming curve that emulates the dimming curve of incandescent lamps on a DMX dimmer. This curve offers the most control at low intensities.

**Linear** A dimming curve with a linear relationship between DMX input and LED power.

#### ► To set a fixture's dimming curve:

1. Select Configuration > Dimming Curve.
2. Select Normal, Tungsten, or Linear.
3. Press Enter to confirm your selection.

## Setting LED Transition Speed

Normally, LEDs react to DMX or other control data instantaneously. You may want to slow down the reaction speed for smoother transitions when the intensity of LED channels changes. ColorBlaze TRX offers five levels of decreasing LED transition speed, from Fast (instant snap changes) to Delay 4 (slowest transition speed).

### ► To set a fixture's LED transition speed:

1. Select Configuration > Transition Speed.
2. Select Fast, Delay 1, Delay 2, Delay 3, or Delay 4.
3. Press Enter to confirm your selection.

## Enabling and Disabling the Intensity Channel

Enabling the intensity channel lets you adjust the brightness of all LED channels proportionally using one slider on a DMX console. For example, you can set a color that you want, then adjust the brightness with the assigned slider while maintaining the color value.

You can use the Single-Channel Fixture icon in ColorPlay 3 (version 1.10 and higher) to represent and control the intensity channel in a ColorPlay 3 light show. Refer to the ColorPlay 3 User Guide for more information.

### ► To enable the intensity channel:

1. Select Configuration > Intensity Channel.
2. Select Enabled.
3. Press Enter to confirm your selection.

### ► To disable the intensity channel:

1. Select Configuration > Intensity Channel.
2. Select Disabled.
3. Press Enter to confirm your selection.

## Using Master / Slave Mode

When in master mode, a ColorBlaze TRX fixture acts as a master controller for fixtures that follow it in a run. When connected together properly, downstream slave fixtures can be configured to show the same output as the master fixture.

You can configure the master fixture to send DMX or Ethernet (KiNET) data. For data integrity reasons, do not set the master mode output type to KiNET when connected to ColorPlay 3, or to DMX when the fixture is using the DMX trigger or receiving DMX data from a controller or other data source. Note that you may have trouble communicating with slave fixtures via Ethernet when a master fixture is sending data in KiNET output mode.

### ► To put a fixture in master or slave mode:

1. Select Configuration > Master / Slave Mode > Master / Slave Mode.
2. Select Master or Slave.
3. Press Enter to confirm your selection.

### ► To set master mode output type:

1. On a ColorBlaze TRX fixture in Master mode, select Configuration > Master / Slave Mode > Output.
2. Select KiNET or DMX.
3. Press Enter to confirm your selection.

✳ Make sure that your addressing scheme accounts for the additional DMX addresses that the intensity channel requires. Refer to "Using the Intensity Channel" on page 14 for more information.

✳ For guidelines on the proper configuration of ColorBlaze TRX fixtures in master / slave mode, refer to "Master / Slave Mode" on page 15.

✳ You may need to set the KiNET output mode (1 or 2) to control Ethernet-based devices in Master mode. Refer to "Setting a Fixture's KiNET Output Mode" on page 33 for details.

## Configuring DMX Triggers

You can enable a DMX trigger to implement convenient playback of stored triggers from a lighting console. To enable a DMX trigger on a ColorBlaze TRX fixture, you use the DMX Trigger command on the fixture's Configuration menu to assign an unused DMX address to serve as the trigger channel. Then you assign that same DMX address to a channel on your lighting console. Regions 1 through 10 activate shows 1 through 10 from the ColorBlaze TRX fixture's SD card, while region 0 deactivates the trigger.

### ► To enable the DMX trigger for a ColorBlaze TRX fixture:

1. Select Configuration > DMX Trigger > DMX Trigger.
2. Select Enabled.
3. Press Enter to confirm your selection.

### ► To set the DMX trigger address for the enabled DMX trigger:

1. Select Configuration > DMX Trigger > Address.
2. Select an unused DMX address (1 – 512).
3. Press Enter to confirm your selection.

### ► To disable the DMX trigger for a ColorBlaze TRX fixture:

1. Select Configuration > DMX Trigger > DMX Trigger.
2. Select Disabled.
3. Press Enter to confirm your selection.

\* For guidelines on setting up DMX triggers and a table of values, refer to "Using DMX Triggers" on page 17.

\* For data integrity reasons, do not set a fixture in Master mode to output DMX when using the DMX trigger.

## Regulating Fan Speed

To maintain safe internal operating temperatures, ColorBlaze TRX fixtures are equipped with variable-speed onboard fans (two for each 2 ft fixture, six for each 6 ft fixture). By default, ColorBlaze TRX fans are thermally regulated — that is, the fan speed is automatically adjusted based on internal operating temperatures. You can also set the fans to a constant speed, which can limit the amount of fan noise in hot operating environments where fans need to run continuously.

### ► To regulate a fixture's fan speed:

1. Select Configuration > fan Control.
2. Select Thermally Regulated or Constant Fan Speed.  
If you select Constant Fan Speed, select a fan speed from 1 (1100 RPM) to 10 (2520 RPM). Press Enter to confirm your selection.
3. Press Enter to confirm your selection.

## Setting a Fixture's Ethernet Properties

Each ColorBlaze TRX fixture comes factory-set with a unique IP address. If necessary, you can change a fixture's IP address. To ensure that fixtures function properly, make sure that the IP addresses of all ColorBlaze TRX fixtures within a single installation are unique.

Normally, Ethernet controllers segment data based on fixtures' IP addresses. This means that each fixture effectively functions as its own universe. For Ethernet controllers that broadcast data to all IP addresses, such as ColorDial Pro, you can create sub-groups of ColorBlaze TRX fixtures within an installation by assigning them to different universes. Each ColorBlaze TRX fixture is assigned to universe 0 by default.



► **To change a fixture's IP address:**

1. Select Configuration > Ethernet > IP Address.
2. Select IP Address[0]. Select the desired value for this byte (0 – 255), then press Enter to confirm your selection.
3. Repeat step 2 for the other bytes in the address (IP Address[1], IP Address[2], and IP Address[3]), as needed.

► **To set a fixture's universe:**

1. Select Configuration > Ethernet > Universe.
2. Select a universe (0 – 255).
3. Press Enter to confirm your selection.

## Setting a Fixture's KiNET Output Mode

When a fixture is in Master mode and is configured to output KiNET data, you can set the KiNET output mode (1 or 2) to add other Philips Color Kinetics devices that accept Ethernet input to the end of the run. The master ColorBlaze TRX fixture acts as a controller for these devices, allowing you to mix different fixture types in a run.

KiNET output mode is set to 1 by default. Most Philips Color Kinetics devices, including ColorBlaze TRX fixtures, accept both KiNET mode 1 and KiNET mode 2. Some accept KiNET mode 1 only or KiNET mode 2 only, as shown in the table below.

\* Refer to "Master / Slave Mode" on page 15 for more information.

### KiNET Mode of Ethernet-Enabled Devices

Device	KiNET Mode	
	1	2
ColorBlaze TRX	✓	✓
Data Enabler Pro	✓	✓
eW Accent MX Powercore	✓	✓
iColor Accent MX Powercore	✓	✓
PDS-60 24V DMX / Ethernet	✓	✓
PDS-60ca 7.5V DMX / Ethernet	✓	✓
sPDS-60ca 24V	✓	✓
PDS-60ca 24V Ethernet	✓	
PDS-150e	✓	
sPDS-480ca 7.5V		✓
sPDS-480ca 24V		✓

When you set KiNET output mode to 2, you can also set the number of ports on power / data supplies with multiple ports, such as sPDS-480ca.

► **To change a fixture's KiNET output mode:**

1. Select Configuration > Ethernet > KiNET Output Mode.
2. Select KiNET output mode (1 or 2).
3. Press Enter to confirm your selection.

► **To set the number of output ports on a KiNET 2 device:**

1. Select Configuration > Ethernet > KiNET Num Output Ports.
2. Select the number of ports (1 – 16).
3. Press Enter to confirm your selection.

## Interpreting and Setting the Brightness of the Status LEDs of the Status LEDs

Status LEDs on the right side of the control panel provide feedback about the current functioning of a ColorBlaze TRX fixture

### Status LED Modes

Status LED	Mode	Meaning
Power Status	Blue	Connected to AC power
	Off	Not connected to AC power
Data Status	Blue	In DMX / Ethernet mode and receiving DMX data
	Green	In DMX / Ethernet mode and receiving Ethernet data
	Off	In DMX / Ethernet mode and receiving no data
	Blinking blue and green	In DMX / Ethernet mode and receiving both DMX and Ethernet data
	Yellow	In Standalone mode
	Blinking yellow	In Standalone mode and receiving DMX or Ethernet data
Problem Indicator	Off	No problems
	Red	At least one fan is not operating
	Fast blinking red	Fixture has exceeded thermal protection temperature

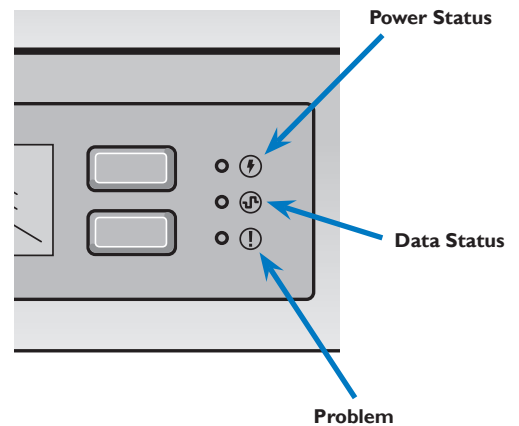

You can set the brightness of the status LEDs, or turn them off.

#### ► To set the brightness of the status LEDs:

1. Select Configuration > User Interface > Status LEDs.
2. Select High, Low, or Off.
3. Press Enter to confirm your selection.

## Flipping the Menu Display

When a fixture is hung upside down or is hard to access, you may find it convenient to flip the orientation of the menu display so that it appears right side up to the operator. When you flip the menu display, the functions of the control buttons are automatically updated to match the display.

#### ► To flip the menu display:

1. Do one of the following:
  - When the menus are locked, press the Flip Display button.
  - When the menus are unlocked, select Configuration > User Interface > Flip Display.
2. Select Yes (menu is upside down) or No (menu is right side up).
3. Press Enter to confirm your selection.

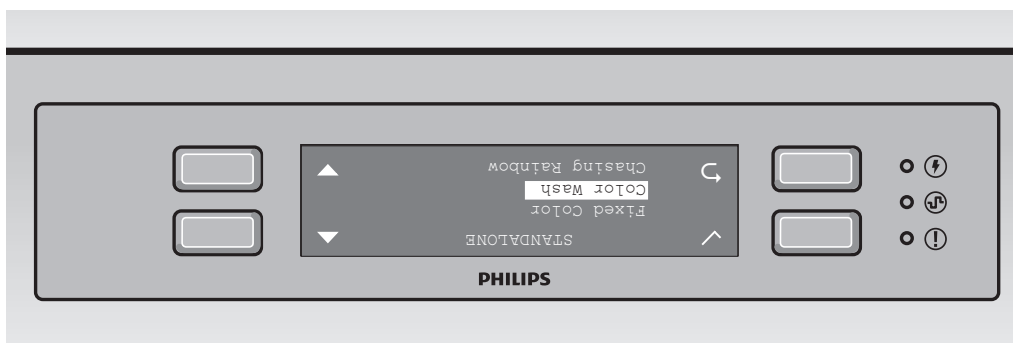

## Setting Display Timeout

The ColorBlaze TRX onboard menus time out and lock after a period of inactivity.

### ► To set menu display timeout:

1. Select Configuration > User Interface > Display Timeout.
2. To set a timeout, select 15 seconds, 30 seconds, 1 minute, or two minutes.
3. Press Enter to confirm your selection.

## Running Fixture Self-Tests

ColorBlaze TRX has a set of built-in self-tests that let you visually check the operation of the menu display, fans, LED channels, and SD card.

### ► To test the proper operation of the menu display:

1. Select Test > User Interface.
2. Press each of the four rubberized selection buttons. (You must press them all within 10 seconds or the test will fail.) If the buttons are operating properly, each button receives a checkmark, and a Button Test Passed message appears. The test then tests the status LEDs, and automatically returns to the Test menu.

### ► To test the proper operation of the fans:

- Select Test > Fans: Auto.  
The test runs, then automatically returns to the Test menu.

### ► To run the automatic LED channel self-test:

- Select Test > LEDs: Auto. In sequence, the test illuminates the red, green, blue, amber, and white LED channels, illuminates all channels dim, illuminates all channels bright, then turns all channels off.

### ► To run a manual LED channel self-test:

1. Select Test > LEDs: Manual.
2. Test the proper operation of the LED channels by using the Move Up and Move Down buttons to select Red, Green, Blue, Amber, White, RGBAW - Dim, RGBAW - Bright, and Off.
3. Press Cancel to end the test.

### ► To test the proper operation of the SD Card:

- Select Test > SD Card. Press Return once the test completes.

### ► To run a complete self-test:

- Select Test > Complete Self Test. The user interface, status LED, fan, LED channel, and SD card tests run in sequence.

## Displaying Fixture Information

You can display current configuration and operational information for a ColorBlaze TRX fixture.

### ► To display the settings overview:

1. Do one of the following:
  - When menus are locked, press the Settings Overview button.
  - When menus are unlocked, select Utilities > Information > Settings Overview.

2. Using the Up and Down buttons, scroll through the list of settings.  
Settings Overview displays information on current starting DMX address, IP address, fixture mode, segment order, dimming curve, transition speed, fixture resolution, color control mode, and MAC address.
3. Press Return to exit Settings Overview.

► **To display firmware versions:**

1. Select Utilities > Information > Firmware Versions.
2. Using the Up and Down buttons, scroll through the list.  
Firmware Versions displays the versions of the firmware currently installed on the main controller board, the LED controller boards (three LED boards for each 2 ft fixture; nine for each 6 ft fixture), and the fan controller boards (one fan board for each 2 ft fixture; 3 fan boards for each 6 ft fixture).
3. Press Return to exit Firmware Versions.

► **To display serial numbers:**

1. Select Utilities > Information > Serial Numbers.
2. Using the Up and Down buttons, scroll through the list.  
Serial Numbers displays the serial numbers assigned to the fixture's main controller board and the LED controller boards (three LED boards for each 2 ft fixture; nine for each 6 ft fixture).
3. Press Return to exit Serial Numbers.

► **To display temperatures:**

1. Select Utilities > Information > Temperature.
2. Using the Up and Down buttons, scroll through the list.  
Temperatures displays, in degrees C, the current ambient temperature, and the internal operating temperatures of the power supply and LED controller boards (three LED boards for each 2 ft fixture; nine for each 6 ft fixture).
3. Press Return to exit Temperature.

► **To display fan speeds:**

1. Select Utilities > Information > Fan Speeds.
2. If necessary, use the Up and Down buttons to scroll through the list.  
Fan Speeds displays, in RPM, the speed of each fan (two fans for each 2 ft fixture; six fans for each 6 ft fixture).
3. Press Return to exit Fan Speeds.

## Resetting System Settings

You can load a fixture's default profile at any time to restore the fixture's initial system settings.

► **To restore a fixture's initial system settings:**

- Select Utilities > Fixture Profiles > Reset System Settings.

# Addressing and Configuring ColorBlaze TRX with QuickPlay Pro

 You can download QuickPlay Pro from [www.philipscolorkinetics.com/support/addressing](http://www.philipscolorkinetics.com/support/addressing).

In Ethernet lighting installations, you can remotely address and configure ColorBlaze TRX fixtures by connecting a computer running QuickPlay Pro addressing and configuration software to the lighting network. You can either connect the computer to an available port on an Ethernet switch, or to the data input on the first ColorBlaze TRX fixture in a series. In Ethernet, QuickPlay Pro will automatically discover all connected fixtures for easy configuration.

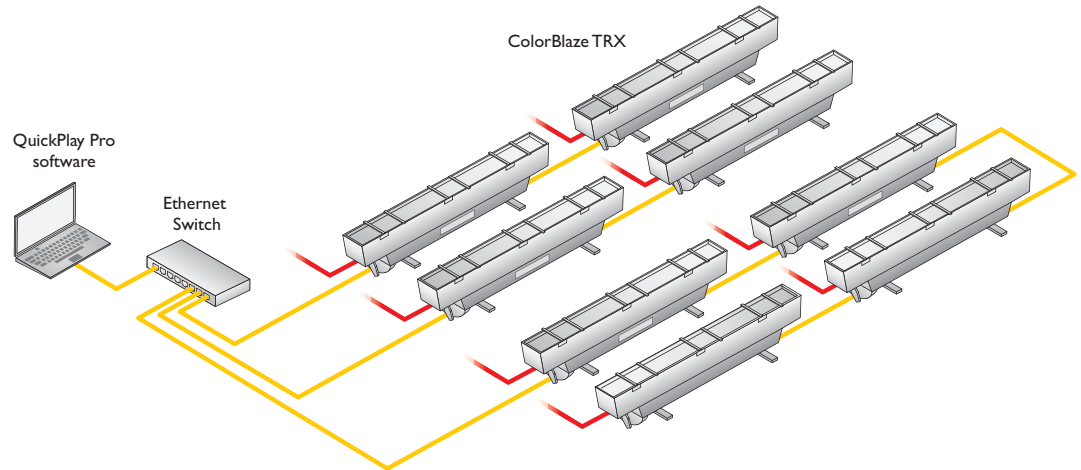

1. Connect a computer running QuickPlay Pro to an available port on an Ethernet switch, or to the data input on the first ColorBlaze TRX fixture in a series, using a standard RJ45 patch cable.
2. Run QuickPlay Pro, and click Fixture Configuration.
3. Click the Refresh button to the right of the Controller list. QuickPlay Pro automatically discovers all connected ColorBlaze TRX fixtures and enters them, by IP address, in the Controller list. Select a fixture to configure from the list.

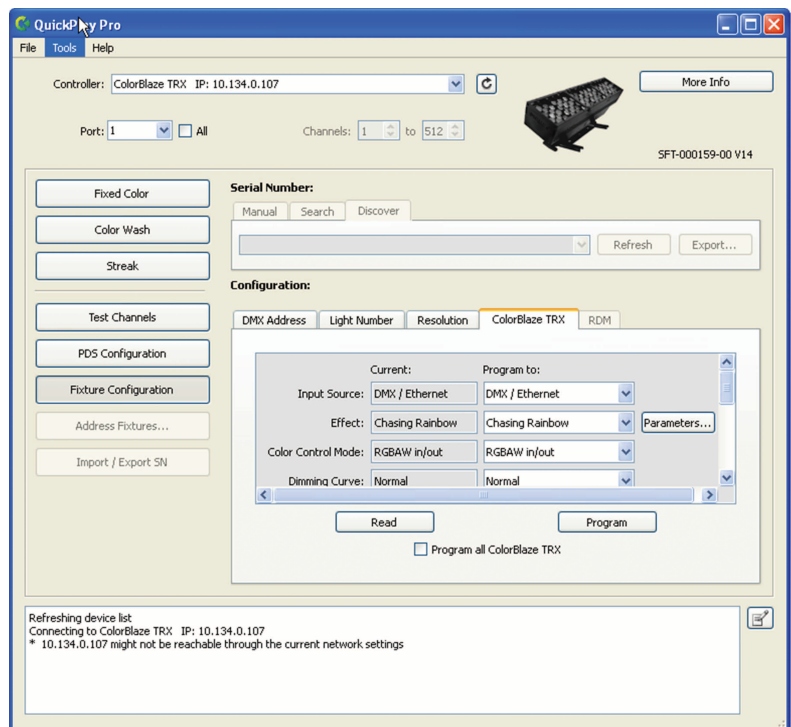

4. Configure the fixture by doing one or more of the following:

- To set the fixture input source, select Standalone or DMX / Ethernet from the Input Source drop-down list.
- To set the pre-set show to display when in Standalone mode, select Fixed Color, Color Wash, or Chasing Rainbow from the Effect drop-down list. To configure pre-set light shows, refer to “Configuring Pre-Set Shows with QuickPlay Pro” on pages 23 – 24.
- To set the fixture’s color control mode, select RGBAW in / out, RGB in / out, or RGB -> RGBAW from the Color Control Mode drop-down list.
- To set the fixture’s dimming curve, select Normal, Linear, or Tungsten from the Dimming Curve drop-down list, then click Program.
- To set the fixture’s LED transition speed, select Fast, Delay 1, Delay 2, Delay 3, or Delay 4 from the Transition Speed drop-down list, then click Program.
- To set the fixture's segment size, select 4 inches, 8 inches, 12 inches, 24 inches, 36 inches (6 ft fixture only), or 72 inches (6 ft fixture only) from the Segment Size drop-down list.
- To set the segment order, select Normal or Reverse from the Segment Order drop-down list.
- To set the orientation of the menu display area, select Yes or No from the Flip Display drop-down list.
- To set the menu display timeout, select 15 sec, 30 sec, 1 min, or 2 min from the Display Timeout drop-down list.
- To set the fan mode, select Thermally Regulated or Constant from the Fan Mode drop-down list.
- When Fan Mode is set to Constant set a fan speed, by selecting a relative speed (1 is slowest, 10 is fastest) from the Constant Fan Speed drop-down list.

5. When you're ready, click Program to apply all changes.

6. Repeat steps 3 – 5 for each fixture you want to address and configure.

\* Refer to “Using the Onboard ColorBlaze TRX Menus” above for descriptions of each of these configuration options.

## Configuring Pre-Set Shows with QuickPlay Pro

When a ColorBlaze TRX show is in Standalone mode, the fixture can display one of a set of pre-set light shows. By default, ColorBlaze TRX displays Fixed Color with all LED channels set to 0 brightness (fixture is black). QuickPlay Pro lets you set parameters for each pre-set show.

\* You can program all discovered ColorBlaze TRX fixtures with the selected settings simultaneously by checking "Program all ColorBlaze TRX" before clicking Program.

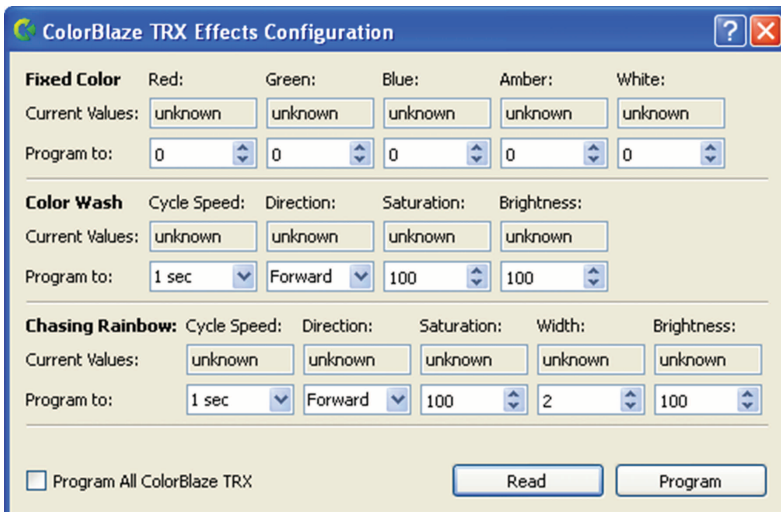

1. Connect QuickPlay Pro to your lighting network, and discover the ColorBlaze TRX fixture you want to configure, as described in the preceding procedure.
2. On the ColorBlaze TRX tab on QuickPlay Pro, click Parameters.
3. Set effect parameters:
  - For Fixed Color, select a brightness for each channel (0 – 255).
  - For Color Wash, set cycle speed (1 second – 1 hour), direction (forward or reverse), saturation (0% – 100%), and brightness (0% – 100%).
  - For Chasing Rainbow, set cycle speed (1 second – 1 hour), direction (forward or reverse), saturation (0% – 100%), width (1 – 170 pixels) and brightness (0% – 100%).
4. To apply the selected settings to all discovered ColorBlaze TRX fixtures, click the Program All ColorBlaze TRX checkbox.
5. When you're ready, click Program to apply all changes.
6. Click the window's close box.

## Updating ColorBlaze TRX Firmware

The ColorBlaze TRX firmware image is periodically updated to improve system performance and functionality. To maximize system performance, make sure your ColorBlaze TRX fixtures are running the most recent version of the firmware.

### Download ColorBlaze TRX Firmware

If a more recent version of the ColorBlaze TRX firmware is available, download the firmware file (.hex extension):

1. Visit the Firmware Updates page at [www.philipscolorkinetics.com/support/downloads/firmware/](http://www.philipscolorkinetics.com/support/downloads/firmware/) to check for the latest firmware version.
2. If a newer firmware image is available, click the link on the Firmware Updates page to download the firmware file to an accessible location on your computer.

### Download CK Firmware Updater

To update the firmware image on a ColorBlaze TRX fixture, you must download and install the CK Firmware Updater application on your computer.

1. Visit the Firmware Updates page at [www.philipscolorkinetics.com/support/downloads/firmware/](http://www.philipscolorkinetics.com/support/downloads/firmware/)
2. Download the Firmware Updater Utility.
3. Decompress the file to an accessible location on your computer and open it.
4. Run the installer, and follow the on-screen instructions.

## Running a ColorBlaze TRX Firmware Update

You can update ColorBlaze TRX firmware using a computer running CK Firmware Updater software.

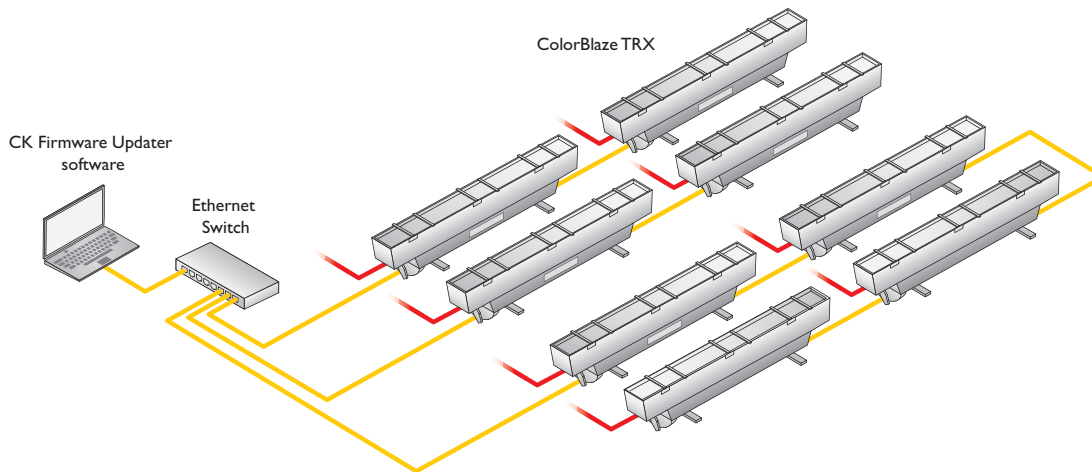

1. Connect a computer to your lighting network using a standard Ethernet cable.
2. Run CK Firmware Updater.
3. From the Interface Select drop-down list, select Ethernet Controllers.
4. From Device Select drop-down list, select ColorBlaze TRX.
5. Click File Select, navigate to the folder to which you downloaded the firmware file (.hex extension), and click Open.
6. Click Discover. CK Firmware Updater discovers the ColorBlaze TRX fixtures installed in the lighting network.
7. Select the ColorBlaze TRX fixture you want to update.
8. Click PROGRAM.
9. Repeat steps 7 and 8 for each ColorBlaze TRX fixture you want to update.

\* Your computer must have a static IP address (of the form 10.x.x.x), and the subnet mask must be set to 255.0.0.0.



Philips Color Kinetics  
3 Burlington Woods Drive  
Burlington, Massachusetts 01803 USA  
Tel 888.385.5742  
Tel 617.423.9999  
Fax 617.423.9998  
www.philipscolorkinetics.com

Copyright © 2011 - 2012 Philips Solid-State Lighting Solutions, Inc. All rights reserved. Chromacore, Chromasic, CK, the CK logo, Color Kinetics, the Color Kinetics logo, ColorBlast, ColorBlaze, ColorBurst, ColorGraze, ColorPlay, ColorReach, iW Reach, eW Reach, eW Fuse, DIMand, EssentialWhite, eV, iColor, iColor Cove, IntelliWhite, iV, iPlayer, Optibin, and Powercore are either registered trademarks or trademarks of Philips Solid-State Lighting Solutions, Inc. in the United States and / or other countries. All other brand or product names are trademarks or registered trademarks of their respective owners. Due to continuous improvements and innovations, specifications may change without notice. DAS-000076-00 R02.05-12