



## INSTALLATION GUIDE & HARDWARE REFERENCE

Supplied by:

**lightmoves**

Melbourne  
03 9701 2500

Sydney  
02 9737 8988

[info@lightmoves.com.au](mailto:info@lightmoves.com.au) [www.lightmoves.com.au](http://www.lightmoves.com.au)



# CONTENTS

<b>Welcome</b> .....	<b>7</b>
Overview .....	7
Software Installation .....	7
<b>LPC Installation &amp; hardware reference</b> .....	<b>8</b>
LPC Installation .....	8
LPC Layout .....	8
LPC Versions .....	8
Power Supply .....	8
Grounding .....	9
Realtime Clock Battery .....	9
Memory Card .....	10
Status LEDs .....	10
Error Codes .....	10
Reset Switch .....	10
Watchdog .....	10
Ports .....	11
<b>TPC Installation &amp; hardware reference</b> .....	<b>14</b>
TPC Installation .....	14
TPC Layout .....	14
Power Supply .....	15
Realtime Clock Battery .....	16
Memory Card .....	16
Status LEDs .....	16
Error Codes .....	17
Reset Switch .....	17
Config Switch .....	17
Watchdog .....	17
Learning IR Receiver .....	17
<b>EXT Installation &amp; hardware reference</b> .....	<b>18</b>
EXT Installation .....	18
EXT Layout .....	18

Power Supply .....	18
Grounding .....	19
Status LEDs .....	19
Error Codes .....	19
Reset Switch .....	20
Ports .....	20
<b>LPC X Installation &amp; hardware reference .....</b>	<b>24</b>
LPC X Installation .....	24
LPC X Layout .....	24
LPC X Versions .....	24
Power Supply .....	24
Grounding .....	25
Realtime Clock Battery .....	25
Memory Storage .....	25
Status LEDs .....	25
Error Codes .....	25
Reset Switch .....	26
Watchdog .....	26
Ports .....	26
<b>VLC Installation &amp; hardware reference .....</b>	<b>28</b>
VLC Installation .....	28
VLC Layout .....	28
VLC Versions .....	28
Power Supply .....	28
Grounding .....	29
Realtime Clock Batteries .....	29
Memory Storage .....	29
Status LEDs .....	29
Error Codes .....	29
Reset Switch .....	30
Watchdog .....	30
Ports .....	30

<b>RIO Installation &amp; hardware reference</b> .....	<b>32</b>
RIO Installation .....	32
RIO Layout .....	32
RIO Versions .....	32
Power Supply .....	33
Grounding .....	33
Status LEDs .....	33
Error Codes .....	33
Address Wheel .....	34
Reset Switch .....	34
Watchdog .....	34
Ports .....	34
<b>BPS Installation &amp; hardware reference</b> .....	<b>38</b>
BPS Installation .....	38
BPS Versions .....	38
BPS Layout .....	39
Power Supply .....	39
Status LEDs .....	39
Error Codes .....	40
Address Wheel .....	40
Reset Switch .....	40
Watchdog .....	40
Learning IR Receiver .....	41
<b>POE Installation &amp; hardware reference</b> .....	<b>44</b>
POE Installation .....	44
POE Layout .....	44
Power Supply .....	44
Power Supply Choice & PoE Loading .....	45
Grounding .....	45
Status LEDs .....	45
<b>RDM Installation &amp; hardware reference</b> .....	<b>46</b>
RDM Installation .....	46

RDM Layout .....	46
Power Supply .....	46
Grounding .....	47
Status LEDs .....	47
DMX Thru Termination .....	47
DMX & RDM Guidelines .....	47
<b>CxD Installation &amp; hardware reference .....</b>	<b>48</b>
CxD Installation .....	48
CxD Layout .....	48
CxD Versions .....	48
Power Supply .....	49
Grounding .....	49
Status LEDs .....	49
DMX Thru Termination .....	49
DMX & RDM Guidelines .....	49
Test & Address Wheel .....	50
LED Fixture Types (Low Voltage Architectural Only) .....	50
Fixture Ganging .....	51
CxD Version & Power Supply Selection .....	51
<b>Warranty &amp; Compliance Information .....</b>	<b>56</b>

## WELCOME

Thank you for purchasing a Pharos Architectural Controls Limited product, we hope that it fulfills your expectations and provides a lifetime of reliable service.

If you have any questions or require technical support please contact:

Email	support@pharoscontrols.com
Telephone	+44-(0)20-7471-9449

Technical specifications of this and other Pharos products can be found on our website at <http://www.pharoscontrols.com>.

## OVERVIEW

The Pharos control solution has two complementary parts: the installed Controllers and Remote Devices, and the Designer software which runs on any personal computer and is only required when creating or modifying the presentation.

This guide is primarily intended as a reference for the Pharos hardware installation. For Designer software help please refer to the on-line documentation (once installed, see below) .

## SOFTWARE INSTALLATION

- Microsoft Windows (see Designer Help for supported OS):

Download the appropriate installer from [pharoscontrols.com](http://pharoscontrols.com) and run the Installer

- Apple Macintosh (see Designer Help for supported OS):

Download the appropriate installer from [pharoscontrols.com](http://pharoscontrols.com) and run the Installer.

## LPC INSTALLATION

The units are 100% solid state and have been qualified to operate in a dry environment within a temperature range of 0°C to 50°C (32°F to 122°F). Sealed IP65 rated consumer units are available for outdoor use, please consult your Pharos distributor or representative.

Since the units require no user intervention once installed they are suitable for remote installation with all configuration and management taking place over an Ethernet network. However it is recommended that access can be gained in the unlikely event of a hardware failure.

## LPC LAYOUT

The following drawing illustrates the layout of the Pharos Lighting Playback Controller, refer to the following sections for details:

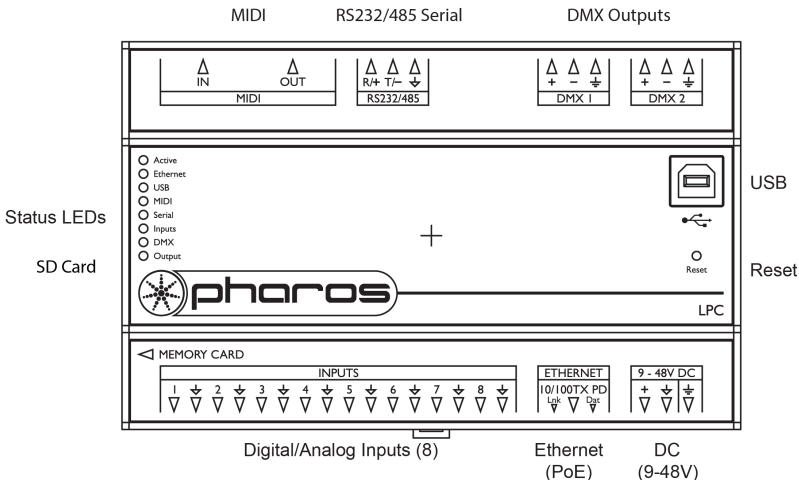

## LPC VERSIONS

There are three versions of the LPC available: LPC 1, LPC 2 and LPC 4. The LPC 1 supports 512 DMX channels, the LPC 2 supports 1024 channels and the LPC 4 supports 2048 channels (of which 1024 channels are eDMX only). All can be used as a stand-alone controller or co-operatively, via an Ethernet network, to form a scalable system.

## POWER SUPPLY

The LPC can be powered in two different ways:

- DC power (9 to 48V)

A limited power source approved to UL60950-1 2nd Edition, CAN/CSA C22.2



No. 60950- 1.07 2nd Edition MUST be used, with an output voltage of 9 to 48V DC.

Such a power supply can be connected directly to the LPC using the DC Input connector. The pins on this connector are marked:

- + Positive input (9 to 48V DC)
- ⚡ Signal ground (0V)
- ⊥ Chassis ground (earth)

The power supply should be connected to the Positive and Signal ground inputs, ensuring the polarity is correct. Where possible, use a 12V (minimum) supply in preference to a 9V supply to ensure some headroom.

The LPC will typically consume 4W.

- Power-over-Ethernet (PoE)

A standard (802.3af) Power-over-Ethernet switch may be used to provide both power and a network connection to the LPC using a single cable.

The LPC operates as a PoE Class 2 device (3.84>6.49W) and will typically consume 4W.

**NOTE:** Power should only be applied using one of the above methods. Redundant operation using both sources is not supported.

**NOTE:** Power must not be disconnected when uploading project data nor during bootloader/firmware updates to the LPC as corruption of the data or software may occur, perhaps even rendering the unit inoperable.

## GROUNDING

The LPC is designed to be mounted on a grounded (earthed) DIN-rail and a dedicated Chassis ground (earth) terminal is also provided which should be connected to a suitable earth.

Additionally, the Signal ground can be tied to Chassis ground to provide a suitable reference but this is not generally recommended.

If in any doubt at all, or if you have unusual power supply or grounding/earthing requirements, then please consult Pharos support.

## REALTIME CLOCK BATTERY

The LPC's internal realtime clock is battery-backed to ensure operation when the unit is not powered. The battery should last for at least 10 years and is easily replaced when necessary, replacement battery: Renata CR2032 Lithium Button Cell.

**CAUTION:** Risk of explosion if battery replaced by incorrect type. Dispose of used batteries according to the manufacturer's instructions.

**ATTENTION:** Il y a un danger d'explosion s'il y a un remplacement incorrect de batterie. Mettre au rebut les batteries usagées conformément aux instructions du fabricant.

## MEMORY CARD

The LPC is shipped with a 2GB SD Memory Card which should be sufficient for most projects since the LPC's data storage is extremely efficient, even with a multitude of imported media files. However, a larger capacity card could of course be fitted if required.

As only the project's programming data resides on the card, the card is also a convenient way to backup data for archiving; the Designer project file for example.

Furthermore, in the event of LPC hardware failure, simply moving the card into a replacement unit with identical or more recent firmware is sufficient to get the project up and running again.

## STATUS LEDS

The Pharos logo will illuminate when power is applied to the LPC. The red LEDs on the front of the LPC indicate the unit's current status.

The Active LED illuminates once the boot up procedure has completed and is indicative of a fully functional unit.

The Ethernet LED indicates Pharos-related network activity (not network link, see Ethernet port later) while the remaining LEDs indicate communication on the various ports of the LPC.

The Output LED indicates that a valid project file has been loaded from the memory card and that playback & data output has started.

The DMX LED indicates that valid DMX512 data is being output from the DMX ports.

## ERROR CODES

Additionally the red status LEDs are used to indicate any boot failures of the LPC that prevent the unit from going active. These codes are outlined below and in all cases the Active LED will be off.

- Ethernet & USB double flashing - failed to boot firmware (follow the LPC recovery procedure detailed in Designer Help)
- Ethernet, MIDI & USB triple flashing - memory card missing (insert or replace card)

## RESET SWITCH

The LPC may be reset by inserting a small blunt object into the reset hole on the front of the LPC to depress the reset switch. The switch should be held for at least one second.

**NOTE:** The reset must not be operated when uploading project data nor during bootloader/firmware updates to the LPC as corruption of the data or software may occur, perhaps even rendering the unit inoperable.

## WATCHDOG

The internal "watchdog" is enabled by default to reset automatically the LPC in case of a software crash as a result of either a coding error ("bug") or a random electromagnetic event

such as a power brown-out or spike, nearby lightning strike or static discharge. Please refer to the Designer Help to learn how to disable this feature (not recommended).

## PORTS

- RS232/RS485 Serial Port

The serial port's protocol (RS232 or RS485), data rate and format settings (baud, parity, stop bits, etc.) are configured using Designer.

In RS232 mode, the port operates in full duplex with the following pinout:

R/+ Receive

T/- Transmit

⊕ Signal ground

In RS485 (and DMX In) mode, the port operates in half duplex with the following pinout:

R/+ Data +

T/- Data -

⊕ Signal Ground

The serial port is not isolated from the LPC's power supply. If isolation is required, it must either be provided by the connected device or a separate isolator should be used.

- MIDI Input and Output

The MIDI input and output connectors are standard 5 pin DIN connections. They may be connected directly to any standard MIDI device.

- DMX Outputs

Two DMX outputs are provided. An LPC 1 will output on both the same DMX universe data, an LPC 2 will output a separate universe on each. The pins on these connectors are marked:

+ Data + ('Hot' or 'True')

- Data - ('Cold' or 'Complement')

⊕ Chassis ground (shield)

To make up a cable to a 5 pin XLR the following connections should be made:

LPC: 5 pin XLR:

Data +	+	3
Data -	-	2
Shield	⏏	1

The DMX ports are by default not isolated from the LPC's ground connection which is the recommended configuration for driving isolated inputs - the majority of DMX receivers.

If required this may be changed by removing the top cover of the LPC and removing the jumper marked 'JPI', located to the right of the DMX ports. The two DMX ports will then be optically isolated from the LPC's internal circuitry although not from each other.

- Digital/Analog Inputs

The LPC features 8 digital/analog inputs on one 16 way connector. To connect an input signal to the LPC one connection should be made to the desired input pin, marked '1' to '8', and the other should be made to the adjacent signal ground pin.

The inputs can be individually configured via Designer to operate in one of three modes:

**Contact closure:** An external volt-free switch may be connected between the input pin and the signal ground pin.

In this mode, the input pin is internally pulled-up to 5V via a 2.2Kohm resistor, so the switch only needs to be rated at 5V, 2.5mA or greater.

**Digital input:** An external voltage source (such as a 12VDC trigger output) may be connected between the input pin and the signal ground pin.

In this mode, the input pin is internally pulled down to 0V via a 2Mohm resistor and the maximum input voltage supported is 24VDC.

The LPC may be configured to specify what the 'high' and 'low' threshold voltages are. This facility can be used to provide 'Schmitt trigger' action.

**Analog input:** An external voltage source (such as a 0-10V analog signal) may be connected between the input pin and the signal ground pin.

In this mode, the input pin is internally pulled down to 0V via a 2Mohm resistor and the maximum input voltage supported is 24VDC.

The LPC may be configured to specify what the input voltage range is. Voltages inside this range are reported as 0% to 100%.

In all modes, the maximum rated input voltage is 24VDC. The inputs should never be driven with a higher voltage nor negative voltage or damage may occur.

In all modes, all signal ground pins are connected together internally. The digital/analog inputs are not isolated from each other nor the LPC's power supply. If isolation is required, it must either be provided by the connected device or a separate isolator should be used.

- Ethernet

A standard 10/100TX Ethernet connection may be made to the LPC. As the LPC supports Power-over-Ethernet (PoE), a PoE switch or midspan injector can be used. The LEDs on the RJ45 jack itself are useful for debugging the Ethernet installation:

The Lnk LED will illuminate when an Ethernet link has been established.

The Dat LED will illuminate to indicate Ethernet traffic (not just Pharos-relevant).

- USB

The USB port may be used to connect the LPC to a PC to upload project data and update the LPC's internal operating software.

**NOTE:** Ports and third party equipment can be damaged when plugging or unplugging an energised system (hot-plugging). It is therefore advisable to remove power before making or breaking port connections.

## TPC INSTALLATION

The Pharos Touch Panel Controller (TPC) is a fully fledged Controller in its own right with an integrated touch screen user interface. It can also share its user interface with other Pharos Controllers when operating as part of a system across an Ethernet network.

The units are designed to be permanently installed into UK double-gang or custom back boxes (supplied separately). The units are 100% solid state and have been qualified to operate in a dry environment within a temperature range of 0°C to 50°C (32°F to 122°F).

The following diagram illustrates a typical installation:

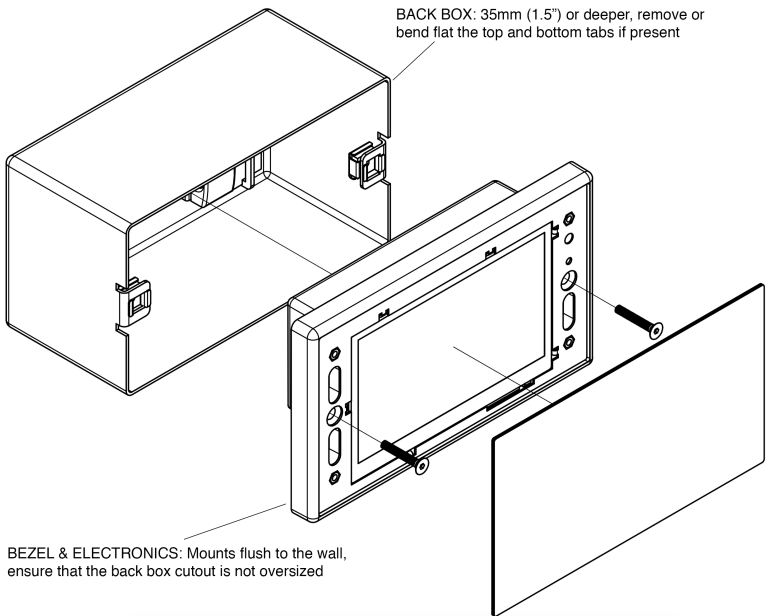

Carefully remove the protective films from the front of the liquid crystal display and the magnetic overlay before final assembly.

## TPC LAYOUT

The following drawing illustrates the layout of a Pharos Touch Panel Controller (shown with overlay removed), refer to the following sections for details:

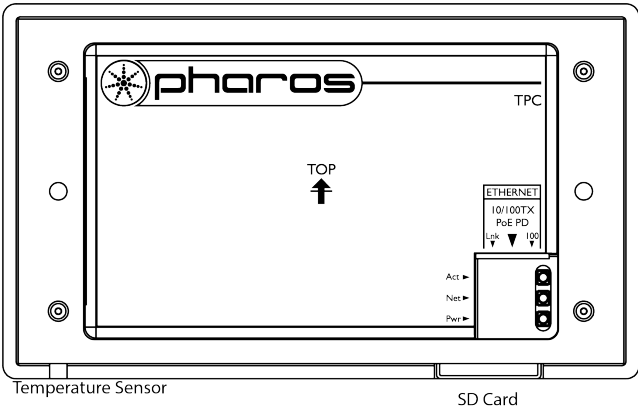

Ethernet  
(PoE)

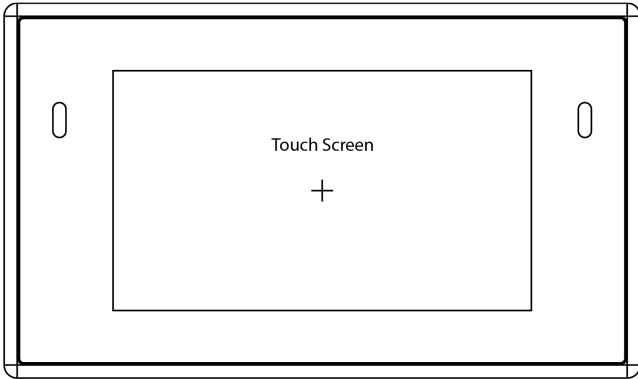

Infra red  
sensor

Proximity  
Sensor  
Ambient  
Light  
Sensor

## POWER SUPPLY

- Power-over-Ethernet (PoE)

A standard (802.3af) Power-over-Ethernet switch should be used to provide both power and a network connection to the TPC using a single cable. Alternatively, if a PoE switch is not available, a PoE midspan injector could be used.

A limited power source approved to UL60950-1 2nd Edition, CAN/CSA C22.2 No. 60950-1.07 2nd Edition MUST be used, with an SELV output voltage.

The TPC operates as a PoE Class 2 device (3.84>6.49W) and will typically consume 4W.

**NOTE:** Power must not be disconnected during firmware updates to the TPC as corruption of the software may occur, perhaps even rendering the unit inoperable.

## **REALTIME CLOCK BATTERY**

The TPC's internal realtime clock is battery-backed to ensure operation when the unit is not powered. The battery should last for at least 10 years and is easily replaced when necessary, replacement battery: Renata CR2032 Lithium Button Cell.

**CAUTION:** Risk of explosion if battery replaced by incorrect type. Dispose of used batteries according to the manufacturer's instructions.

**ATTENTION:** Il y a un danger d'explosion s'il y a un remplacement incorrect de batterie. Mettre au rebut les batteries usagés conformément aux instructions du fabricant.

## **MEMORY CARD**

The TPC is shipped with a 256 MB SD Memory Card which should be sufficient for most projects since the TPC's data storage is extremely efficient, even with a multitude of imported media files. However, a larger capacity card could of course be fitted if required.

As only the project's programming data resides on the card, the card is also a convenient way to backup data for archiving; the Designer project file for example.

Furthermore, in the event of TPC hardware failure, simply moving the card into a replacement unit with identical or more recent firmware is sufficient to get the project up and running again.

## **STATUS LEDS**

The LEDs on the rear of the unit provide the following status information:

**Pwr:** Power - illuminates when the unit is correctly powered.

**Act:** Active - illuminates once the boot up procedure has completed and is indicative of a fully functional unit.

**Net:** Network - illuminates when the unit is sending or receiving Pharos-related data.

**Lnk:** Link - illuminates once the unit has established an Ethernet link.

**100:** 100BASE-TX - illuminates when the Ethernet link is operating at 100Mbit/s.

The LEDs on the front of the unit (under the overlay) provide the following status information:

**Pwr:** Power - illuminates when the unit is correctly powered.

**Act:** Active - illuminates once the boot up procedure has completed and is indicative of a fully functional unit.

Ethernet - illuminates when the unit is sending or receiving Pharos-related data.

**Eth:** Out: Output - indicates that a valid project file has been loaded from the memory card and that playback & data output has started.



## ERROR CODES

Additionally the red status LEDs are used to indicate any boot failures of the TPC that prevent the unit from going active. These codes are outlined below and in all cases the Active LED will be off.

- Ethernet & Output double flashing - failed to boot firmware (follow the TPC recovery procedure detailed in Designer Help)
- Ethernet & Output triple flashing - memory card missing (insert or replace card)

## RESET SWITCH

The TPC may be reset by removing the magnetic overlay and pressing the reset switch. The switch should be held for at least one second.

**NOTE:** The reset must not be operated during firmware updates to the TPC as corruption of the software may occur, perhaps even rendering the unit inoperable.

## CONFIG SWITCH

The TPC may be placed in a configuration mode by removing the magnetic overlay and pressing the config switch, refer to Designer Help for instructions.

## WATCHDOG

An internal "watchdog" will automatically reset the TPC in case of a software crash as a result of either a coding error ("bug") or a random electromagnetic event such as a power brown-out or spike, nearby lightning strike or static discharge.

## LEARNING IR RECEIVER

The TPC may be taught to recognise different IR codes from a standard infra red remote control, refer to Designer Help for instructions.

## EXT INSTALLATION

The Pharos EXT is designed to be permanently installed in a central control room/cupboard or DIN consumer unit for remote deployment. The enclosure and mounting complies with DIN43880 and EN60715 (35/7.5 rail) respectively.

The units are 100% solid state and have been qualified to operate in a dry environment within a temperature range of 0°C to 50°C (32°F to 122°F). Sealed IP65 rated consumer units are available for outdoor use, please consult your Pharos distributor or representative.

Since the units require no user intervention once installed they are suitable for remote installation with all configuration and management taking place over an Ethernet network. However it is recommended that access can be gained in the unlikely event of a hardware failure.

**NOTE:** The EXT should be installed within a fire enclosure. Any SELV parts or wires inside the cabinet should not touch the mains connector of the EXT.

## EXT LAYOUT

The following drawing illustrates the layout of a Pharos EXT, refer to the following sections for details:

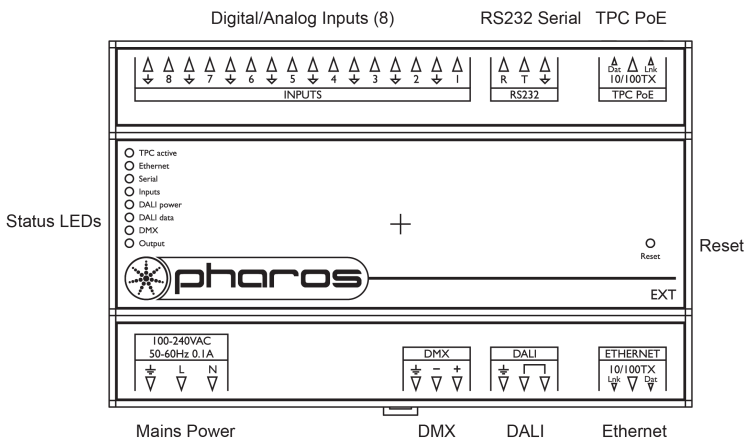

## POWER SUPPLY

The EXT is mains powered via a 100-240V fused switch mode power supply unit compatible with all worldwide mains supply standards; 100-240VAC 50/60Hz.

The EXT will typically consume a maximum of 10W.

**NOTE:** Power must not be disconnected when uploading project data nor during bootloader/firmware updates to the EXT or TPC as corruption of the data or software may occur, perhaps even rendering the unit inoperable.

**CAUTION:** The EXT is a permanently connected device. A readily accessible two-pole disconnect device with at least 3mm contact separation shall be incorporated in the building installation wiring.

**ATTENTION:** L'EXT est un équipement connecté en permanence. Un dispositif de déconnexion à deux pôles facilement accessible avec au moins une séparation de contact de 3mm doit être incorporé au câblage d'installation du bâtiment.

## **GROUNDING**

The EXT must be correctly grounded to electrical safety earth at all times.

## **STATUS LEDS**

The Pharos logo will illuminate when power is applied to the EXT. The red LEDs on the front of the EXT indicate the unit's current status.

The TPC active LED will light continuously once the EXT has connected to a project running on a TPC.

The Ethernet LED indicates Pharos-related network activity (not network link, see Ethernet port later) while the remaining LEDs indicate communication on the various ports of the EXT.

The Output LED indicates that a valid project file has been loaded from the memory card on the connected TPC and that playback & data output has started.

The DMX LED indicates that valid DMX512 data is being output from the DMX port.

## **ERROR CODES**

Additionally the red status LEDs are used to indicate any boot failures to the EXT that prevent the unit from going active. This code is outlined below:

- 1 flash - Invalid firmware version (reload firmware from Designer)
- 2 flashes - Invalid device type or serial number
- 3 flashes - Internal memory test error
- 4 flashes - Unable to perform factory restore due to corrupt factory firmware
- 5 flashes - Current firmware is corrupt, no valid firmware versions available to restore
- 6 flashes - Restored firmware is corrupt

Codes 2 through 6 indicate a hardware error; please consult your distributor, representative or Pharos support for assistance.

## RESET SWITCH

The EXT may be reset by inserting a small blunt object into the reset hole on the front of the EXT to depress the reset switch. The switch should be held for at least one second. This will not reset the connected TPC.

**NOTE:** The reset must not be operated when uploading project data nor during bootloader/firmware updates to the EXT or TPC as corruption of the data or software may occur, perhaps even rendering the unit inoperable.

## PORTS

- RS232 Serial Port

The serial port's data rate and format settings (baud, parity, stop bits, etc.) are configured using Designer.

The port operates in full duplex with the following pinout:

R/+ Receive

T/- Transmit

⊕ Signal ground

The serial port is not isolated from the EXT's power supply. If isolation is required, it must either be provided by the connected device or a separate isolator should be used.

- DMX Output

The pins on this connector are marked:

+ Data + ('Hot' or 'True')

- Data - ('Cold' or 'Complement')

⊕ Chassis ground (shield)

To make up a cable to a 5 pin XLR the following connections should be made:

	EXT:	5 pin XLR:
Data +	+	3
Data -	-	2
Shield	⊕	1

The DMX port is isolated from the EXT's ground connection.

- Digital/Analog Inputs

The EXT features 8 digital/analog inputs on one 16 way connector. To connect

an input signal to the EXT, one connection should be made to the desired input pin, marked '1' to '8', and the other should be made to the adjacent signal ground pin.

The inputs can be individually configured via Designer to operate in one of three modes:

**Contact closure:** An external volt-free switch may be connected between the input pin and the signal ground pin.

In this mode, the input pin is internally pulled-up to 5V via a 2.2Kohm resistor, so the switch only needs to be rated at 5V, 2.5mA or greater.

**Digital input:** An external voltage source (such as a 12VDC trigger output) may be connected between the input pin and the signal ground pin.

In this mode, the input pin is internally pulled down to 0V via a 2Mohm resistor and the maximum input voltage supported is 24VDC.

The EXT may be configured to specify what the 'high' and 'low' threshold voltages are. This facility can be used to provide 'Schmitt trigger' action.

**Analog input:** An external voltage source (such as a 0-10VDC analog signal) may be connected between the input pin and the signal ground pin.

In this mode, the input pin is internally pulled down to 0V via a 2Mohm resistor and the maximum input voltage supported is 24VDC.

The EXT may be configured to specify what the input voltage range is. Voltages inside this range are reported as 0% to 100%.

In all modes, the maximum rated input voltage is 24VDC. The inputs should never be driven with a higher voltage nor negative voltage or damage may occur.

In all modes, all signal ground pins are connected together internally. The digital/analog inputs are not isolated from each other nor the EXT's power supply. If isolation is required, it must either be provided by the connected device or a separate isolator should be used.

- DALI

A DALI bus interface is provided on a 3 way connector:

- ┌ DALI bus (polarity insensitive)
- └ DALI bus (polarity insensitive)
- ⊕ Chassis ground (for optional shield)

The DALI data LED will indicate valid data on the bus.

**NOTE:** The DALI bus requires a dedicated DALI bus power supply to function, the DALI power LED will illuminate solidly to indicate suitable (9-26V) power. The LED will be off for no power or flash to indicate out of range power.

- TPC PoE

Specifically designed to provide power and data to a connected TPC. The LEDs on the RJ45 jack itself are useful for debugging the connection between the EXT and a TPC:

The Lnk LED will illuminate when an Ethernet link has been established.

The Dat LED will illuminate to indicate Ethernet traffic between the EXT and a TPC.

**NOTE:** The TPC PoE port is designed to work with the TPC alone. Connecting any other Pharos or third party devices to this port could damage the device and/or the EXT.

- Ethernet

A standard 10/100TX Ethernet connection may be made to the EXT. The LEDs on the

RJ45 jack itself are useful for debugging the Ethernet installation:

The Lnk LED will illuminate when an Ethernet link has been established.

The Dat LED will illuminate to indicate Ethernet traffic (not just Pharos-relevant).

**NOTE:** Ports and third party equipment can be damaged when plugging or unplugging an energised system (hot-plugging). It is therefore advisable to remove power before making or breaking port connections.



## LPC X INSTALLATION

The Pharos LPC X is designed to be rack mounted in a central control room for fixed installations or flight cased for touring applications. The IU enclosure and 19" rack mounting complies with IEC 60297.

The unit is largely solid state and has been qualified to operate in a dry environment within a temperature range of 0°C to 50°C (32°F to 122°F).

**NOTE:** Particular attention must be paid to cooling; under no circumstances should the airflow to the heat sinks be restricted and a rack fan cooling unit should be considered when multiple units are stacked together to maintain the correct ambient temperature.

Since the unit requires no user intervention once installed it is suitable for remote installation with all configuration and management taking place over an Ethernet network. However it is recommended that access can be gained in the unlikely event of a hardware failure.

## LPC X LAYOUT

The following drawings illustrate the layout of the LPC X, refer to the following sections for details:

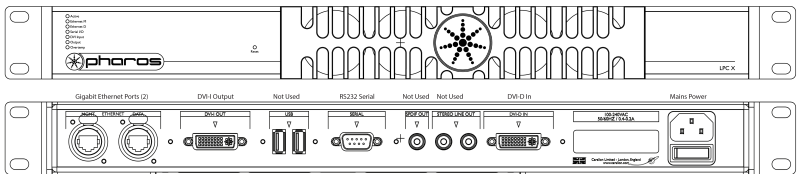

## LPC X VERSIONS

There are multiple versions of the LPC X that differ only in the maximum number of control channels that can be accommodated. For example, the LPC 10 can control 10 DMX universes (5,120 channels) while the LPC 100 can control 100 DMX universes (51,200 channels).

The LPC X can be used as a stand-alone controller or co-operatively with other Pharos Controllers and Remote Devices, via an Ethernet network, to form a scalable system.

## POWER SUPPLY

The LPC X is mains powered via a switched, universal input power supply unit (PSU) compatible with all worldwide mains supply standards; 100-250V 50/60Hz.

The LPC X will typically consume a maximum of 40-75W (LPC 100).

**NOTE:** Power must not be disconnected when uploading project data nor during firmware updates to the LPC X as corruption of the data or software may occur, perhaps even rendering the unit inoperable.

UK, EU and US mains IEC cables are provided.



**CAUTION:** For pluggable equipment, the socket outlet shall be installed near the equipment and shall be easily accessible.

**ATTENTION:** En cas d'équipement enfichable, la prise doit être montée près de l'équipement et doit offrir un accès facile.

## **GROUNDING**

The LPC X must be correctly grounded to electrical safety earth at all times.

## **REALTIME CLOCK BATTERY**

The LPC X's internal realtime clock is battery-backed to ensure operation when the unit is not powered. The battery should last for at least 10 years and are easily replaced when necessary, replacement battery: Renata CR2032 Lithium Button Cell.

**CAUTION:** Risk of explosion if battery replaced by incorrect type. Dispose of used batteries according to the manufacturer's instructions.

**ATTENTION:** Il y a un danger d'explosion s'il y a un remplacement incorrect de batterie. Mettre au rebut les batteries usagées conformément aux instructions du fabricant.

## **MEMORY STORAGE**

The LPC X is shipped with a 16GB SSD which should be sufficient for most projects since the LPC X's data storage is extremely efficient, even with a multitude of imported media files.

## **STATUS LEDS**

The Pharos logo will illuminate when power is applied to the LPC X. The red LEDs above indicate the unit's current status.

The Active LED flashes throughout the boot up procedure and lights solidly once this has been completed and is indicative of a fully functional unit.

The Ethernet LEDs indicates Pharos-related network activity (not network link) while other LEDs indicate communication on the various ports of the LPC X.

The Output LED indicates that a valid project file has been loaded from the memory card and that playback & data output (eDMX & DVI) has started.

The Overtemp LED will illuminate if the processor core(s) reaches 95°C (203°F) indicating a fault in the system's cooling, typically caused by raised ambient temperatures. Consult the web interface's home page to monitor the system temperatures and take remedial action.

## **ERROR CODES**

Additionally the red status LEDs are used to indicate any boot failures of the LPC X that prevent the unit from going active.

Error codes are indicated by double flashing the Ethernet M, Ethernet D and Serial I/O LEDs, followed by a 1 second pause.

The bottom three LEDs indicate the error:

- DVI Input - No SSD detected
- Output - Corrupt SSD - recover from USB
- Overtemp - Invalid hardware type

## RESET SWITCH

The LPC X may be reset by inserting a small blunt object into the reset hole on the front panel to depress the reset switch. The switch should be held for at least one second.

**NOTE:** The reset must not be operated when uploading project data nor during bootloader/firmware updates to the LPC X as corruption of the data or software may occur, perhaps even rendering the unit inoperable.

## WATCHDOG

The internal “watchdog” is enabled by default to reset automatically the LPC X in case of a software crash as a result of either a coding error (“bug”) or a random electromagnetic event such as a power brown-out or spike, nearby lightning strike or static discharge. Please refer to the Designer Help to learn how to disable this feature (not recommended).

## PORTS

- Ethernet 1 - MGMT

A standard 10/100/1000BASE-T Ethernet connection may be made to this port for

management and networking to other Pharos Controllers and Remote Devices.

- Ethernet 2 - DATA

A standard 10/100/1000BASE-T Ethernet connection may be made to this port to output data to lighting fixtures using Ethernet protocols (eDMX) such as ArtNet and KiNet.

- DVI-I OUT

A standard DVI-I connection may be made to this port to route output data to the lighting fixtures using the Digital Video Interface.

- Serial Port

The RS232 serial port may be connected directly to a PC using a null modem cable. Other devices may require different cables depending on their pinout. The serial port is a 9 pin male D connector with the following pinout:

I: DCD

- 2: Receive data (RXD)
- 3: Transmit data (TXD)
- 4: DTR
- 5: Signal ground
- 6: DSR
- 7: RTS
- 8: CTS
- 9: RI

The serial port is not isolated from the LPC X's power supply. If isolation is required, it must either be provided by the connected device or a separate isolator should be used.

- DVI-D Input

This port is not supported at the time of writing (refer to the current Designer Help).

- USB x2

These ports are not supported at the time of writing (refer to the current Designer Help).

- SPDIF OUT

This port is not supported at the time of writing (refer to the current Designer Help).

- Stereo Line Out

This port is not supported at the time of writing (refer to the current Designer Help).

**NOTE:** Ports and third party equipment can be damaged when plugging or unplugging an energised system (hot-plugging). It is therefore advisable to remove power before making or breaking port connections.

## VLC INSTALLATION

The Pharos VLC is designed to be rack mounted in a central control room for fixed installations or flight cased for touring applications. The 1U enclosure and 19" rack mounting complies with IEC 60297.

The unit is largely solid state and has been qualified to operate in a dry environment within a temperature range of 0°C to 50°C (32°F to 122°F).

**NOTE:** Particular attention must be paid to cooling; under no circumstances should the airflow to the heat sinks be restricted and a rack fan cooling unit should be considered when multiple units are stacked together to maintain the correct ambient temperature.

Since the unit requires no user intervention once installed it is suitable for remote installation with all configuration and management taking place over an Ethernet network. However it is recommended that access can be gained in the unlikely event of a hardware failure.

## VLC LAYOUT

The following drawings illustrate the layout of the VLC, refer to the following sections for details:

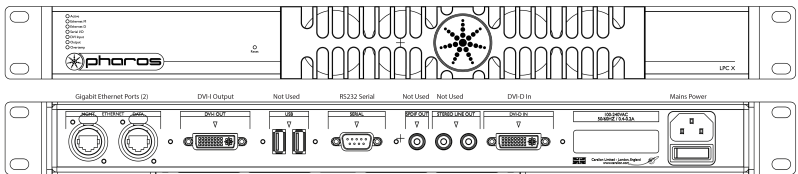

## VLC VERSIONS

There are multiple versions of the VLC that differ only in the maximum number of control channels that can be accommodated. For example, the VLC 50 can control 50 DMX universes (25,600 channels) while the VLC 1500 can control 1500 DMX universes (768,000 channels).

The VLC can be used as a stand-alone controller or co-operatively with other Pharos Controllers and Remote Devices, via an Ethernet network, to form a scalable system.

## POWER SUPPLY

The VLC is mains powered via a fused, universal input power supply unit (PSU) compatible with all worldwide mains supply standards; 100-250V 50/60Hz. The replacement fuse should be a 250V rated IA T (anti-surge) 20mm cartridge type only.

The VLC will typically consume a maximum of 50-75W (VLC 1500 @ 110-240V).

**NOTE:** Power must not be disconnected when uploading project data nor during firmware updates to the VLC as corruption of the data or software may occur, perhaps even rendering the unit inoperable.

UK, EU and US mains IEC cables are provided.

**CAUTION:** For pluggable equipment, the socket outlet shall be installed near the equipment and shall be easily accessible.

**ATTENTION:** En cas d'équipement enfichable, la prise doit être montée près de l'équipement et doit offrir un accès facile.

## **GROUNDING**

The VLC must be correctly grounded to electrical safety earth at all times.

## **REALTIME CLOCK BATTERIES**

The VLC's internal realtime clock is battery-backed to ensure operation when the unit is not powered. The batteries should last for at least 10 years and are easily replaced when necessary, replacement battery: Renata CR2032 Lithium Button Cell.

**CAUTION:** Risk of explosion if battery replaced by incorrect type. Dispose of used batteries according to the manufacturer's instructions.

**ATTENTION:** Il y a un danger d'explosion s'il y a un remplacement incorrect de batterie. Mettre au rebut les batteries usagées conformément aux instructions du fabricant.

## **MEMORY STORAGE**

The VLC is shipped with a 16Gb SSD which should be sufficient for most projects since the VLC's data storage is extremely efficient, even with a multitude of imported media files.

## **STATUS LEDS**

The Pharos logo will illuminate when power is applied to the VLC. The red LEDs above indicate the unit's current status.

The Active LED flashes throughout the boot up procedure and lights solidly once this has been completed and is indicative of a fully functional unit.

The Ethernet LEDs indicates Pharos-related network activity (not network link) while other LEDs indicate communication on the various ports of the VLC.

The Output LED indicates that a valid project file has been loaded from the memory card and that playback & data output (eDMX & DVI) has started.

The Overtemp LED will illuminate if the processor core(s) reaches 95°C (203°F) indicating a fault in the system's cooling, typically caused by raised ambient temperatures. Consult the web interface's home page to monitor the system temperatures and take remedial action.

## **ERROR CODES**

Additionally the red status LEDs are used to indicate any boot failures of the that prevent the unit from going active.

Error codes are indicated by double flashing the Ethernet M, Ethernet D and Serial I/O LEDs, followed by a 1 second pause.

The bottom three LEDs indicate the error:

- DVI Input - No SSD detected
- Output - Corrupt SSD - recover from USB
- Overtemp - Invalid hardware type

## RESET SWITCH

The VLC may be reset by inserting a small blunt object into the reset hole on the front panel to depress the reset switch. The switch should be held for at least one second.

**NOTE:** The reset must not be operated when uploading project data nor during bootloader/firmware updates to the VLC as corruption of the data or software may occur, perhaps even rendering the unit inoperable.

## WATCHDOG

The internal “watchdog” is enabled by default to reset automatically the VLC in case of a software crash as a result of either a coding error (“bug”) or a random electromagnetic event such as a power brown-out or spike, nearby lightning strike or static discharge. Please refer to the Designer Help to learn how to disable this feature (not recommended).

## PORTS

- Ethernet 1 - MGMT

A standard 10/100/1000BASE-T Ethernet connection may be made to this port for

management and networking to other Pharos Controllers and Remote Devices.

- Ethernet 2 - DATA

A standard 10/100/1000BASE-T Ethernet connection may be made to this port to output data to lighting fixtures using Ethernet protocols (eDMX) such as ArtNet and KiNet.

- DVI-I Output

A standard DVI connection may be made to this port to route output data to the lighting fixtures using the Digital Video Interface.

- RS232 Serial Port

The serial ports may be connected directly to a PC using a null modem cable. Other devices may require different cables depending on their pinout. The serial port is a 9 pin male D connector with the following pinout:

I: DCD

- 2: Receive data (RXD)
- 3: Transmit data (TXD)
- 4: DTR
- 5: Signal ground
- 6: DSR
- 7: RTS
- 8: CTS
- 9: RI

The serial port is not isolated from the VLC's power supply. If isolation is required, it must either be provided by the connected device or a separate isolator should be used.

- DVI-D Input

A standard DVI connection may be made to this port to route video data to a Live Video Preset within the project.

- USB

This port is not supported at the time of writing (refer to the current Designer Help).

- SPDIF OUT

This port is not supported at the time of writing (refer to the current Designer Help).

- Stereo Line Out

This port is not supported at the time of writing (refer to the current Designer Help).

**NOTE:** Ports and third party equipment can be damaged when plugging or unplugging an energised system (hot-plugging). It is therefore advisable to remove power before making or breaking port connections.

## RIO INSTALLATION

The Pharos Remote Input/Output Devices (RIO) are ancillary devices that provide additional input and output interfaces to a system. As such, they can not be used on their own but must have at least one Controller present on an Ethernet network to function.

The units are designed to be permanently installed in a control room/cupboard or DIN consumer unit. The enclosure and mounting complies with DIN43880 and EN60715 (35/7.5 rail) respectively.

The units are 100% solid state and have been qualified to operate in a dry environment within a temperature range of 0°C to 50°C (32°F to 122°F). Sealed IP65 rated consumer units are available for outdoor use, please consult your Pharos distributor or representative.

## RIO LAYOUT

The following drawing illustrates the layout of a Pharos Remote Input/Output Device, refer to the following sections for details:

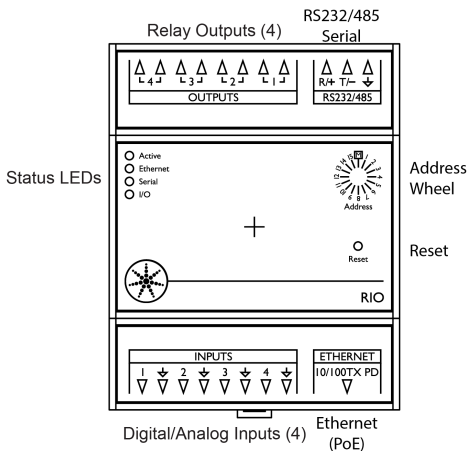

## RIO VERSIONS

There are five versions of the RIO available:

- RIO 80: 8 digital/analog inputs & RS232/485/DMX serial port.
- RIO 44: 4 digital/analog inputs, 4 relay outputs & RS232/485/DMX serial port (shown above).
- RIO 08: 8 relay outputs & RS232/485/DMX serial port.
- RIO A: Balanced stereo audio/timecode input & MIDI input/output ports.
- RIO D: DALI bus interface.



## POWER SUPPLY

- Power-over-Ethernet (PoE)

A standard (802.3af) Power-over-Ethernet switch should be used to provide both power and a network connection to the RIO using a single cable. Alternatively, if a PoE switch is not available, a PoE midspan injector could be used.

The RIO operates as a PoE Class I device (0.44>3.84W) and will typically consume 1.5W.

**NOTE:** Power must not be disconnected during firmware updates to the RIO as corruption of the software may occur, perhaps even rendering the unit inoperable.

## GROUNDING

The RIO is designed to be mounted on a grounded (earthed) DIN-rail, no dedicated Chassis ground (earth) terminal is provided.

The PoE connection (power and data) is completely isolated from all the RIO's ports but the ports are not isolated from each other (except relay outputs, RIO 44 and RIO 08 only).

## STATUS LEDS

The Pharos logo will illuminate when power is applied to the RIO. The red LEDs on the front of the RIO indicate the unit's current status.

The Active LED flashes slowly once the boot up procedure has completed to indicate a fully functional unit. Once the RIO has connected to a project running on a Controller, the Active LED will light continuously.

The Ethernet LED indicates Pharos-related network activity (not network link, see Ethernet port later) while the remaining LEDs indicate communication on the various ports of the RIO.

## ERROR CODES

Additionally the red status LEDs are used to indicate any boot failures of the RIO that prevent the unit from operating. Error codes are displayed by a repeating pattern of flashing all four LEDs a number of times in succession, followed by a 1 second pause:

- 1 flash - Invalid firmware version (reload firmware from Designer)
- 2 flashes - Invalid device type or serial number
- 3 flashes - Internal memory test error
- 4 flashes - Unable to perform factory restore due to corrupt factory firmware
- 5 flashes - Current firmware is corrupt, no valid firmware versions available to restore
- 6 flashes - Restored firmware is corrupt

Codes 2 through 6 indicate a hardware error; please consult your distributor, representative or Pharos support for assistance.

## ADDRESS WHEEL

Multiple RIOs may be used on a single network. Each RIO is uniquely identified by its type (80, 44, 08 or A) and an address setting.

Wheel settings '1' to '15' directly set the RIO's address to the corresponding number. Up to 15 of each type may be addressed in this way. For systems with more than 15 RIOs of a single type, the manual ('M') setting should be used to allow identification using the RIO's serial number rather than the address.

## RESET SWITCH

The RIO may be reset by inserting a small blunt object into the reset hole on the front of the RIO to depress the reset switch. The switch should be held for at least one second.

**NOTE:** The reset must not be operated during firmware updates to the RIO as corruption of the software may occur, perhaps even rendering the unit inoperable.

## WATCHDOG

An internal "watchdog" will automatically reset the RIO in case of a software crash as a result of either a coding error ("bug") or a random electromagnetic event such as a power brown-out or spike, nearby lightning strike or static discharge.

## PORTS

- Digital/Analog Inputs (RIO 80 and RIO 44 only)

The RIO features 8 (RIO 80) or 4 (RIO 44) digital/analog inputs on two (RIO 80) or one (RIO 44) 8 way connectors. To connect an input signal to the RIO, one connection should be made to the desired input pin, marked '1' to '8' (RIO 80) or '1' to '4' (RIO 44), and the other should be made to the adjacent common pin.

The RIO inputs can be individually configured to operate in one of three modes:

**Contact closure:** An external volt-free switch may be connected between the input pin and the signal ground pin.

In this mode, the input pin is internally pulled-up to 5V via a 2.2Kohm resistor, so the switch only needs to be rated at 5V, 2.5mA or greater.

**Digital input:** An external voltage source (such as a 12VDC trigger output) may be connected between the input pin and the signal ground pin.

In this mode, the input pin is internally pulled down to 0V via a 2Mohm resistor and the maximum input voltage supported is 24VDC.

The RIO may be configured using Designer to specify what the 'high' and 'low' threshold voltages are. This facility can be used to provide 'Schmitt trigger' action.

**Analog input:** An external voltage source (such as a 0-10VDC analog signal) may be connected between the input pin and the signal ground pin.

In this mode, the input pin is internally pulled down to 0V via a 2Mohm resistor and the maximum input voltage supported is 24VDC .

The RIO may be configured using Designer to specify what the input voltage range is. Voltages inside this range are reported as 0% to 100%.

In all modes, the maximum rated input voltage is 24VDC . The inputs should never be driven with a higher voltage nor negative voltage or damage may occur.

- Relay Outputs (RIO 08 and RIO 44 only)

The RIO features 8 (RIO 08) or 4 (RIO 44) relay outputs on two (RIO 08) or one (RIO 44) 8 way connectors.

The RIO relays are rated at 48V (AC or DC), 0.25A. This comparatively low rating is due to the use of solid-state relays to ensure silent operation and long-term reliability.

All relay outputs are fully isolated from each other and all other ports.

- RS232/RS485/DMX Serial Port (RIO 80, RIO 44 and RIO 08 only)

The serial port's protocol (RS232 or RS485), data rate and format settings (baud, parity, stop bits, etc.) are configured using Designer. The port can additionally be configured to output 96 channels of DMX512 control data (RDM is not supported).

In RS232 mode, the port operates in full duplex with the following pinout:

R/+ Receive

T/- Transmit

⚡ Signal ground

In RS485 & DMX modes, the port operates in half duplex with the following pinout:

R/+ Data +

T/- Data -

⚡ Signal Ground

- MIDI Input and Output (RIO A only)

The MIDI input and output connectors are standard 5 pin DIN connections. They may be connected directly to any standard MIDI device.

- Analog Audio Input (RIO A only)

Balanced stereo audio input is provided @ 0dBV line level on a 6 way connector:

- + Balanced audio right channel +
- Ⓜ Balanced audio right channel - (tie to ground for unbalanced)
- ⊕ Signal ground
- + Balanced audio left channel +
- Ⓛ Balanced audio left channel - (tie to ground for unbalanced)
- ⊕ Signal ground

The audio input can also accept linear time code (LTC) such as SMPTE/EBU on either channel but not both, configured using Designer. The Audio / LTC LED will indicate peak for audio and valid for time code.

- DALI (RIO D only)

A DALI bus interface is provided on a 3 way connector:

- ┌ DALI bus (polarity insensitive)
- └ DALI bus (polarity insensitive)
- ⊕ Chassis ground (for optional shield)

The DALI data LED will indicate valid data on the bus.

**NOTE:** The DALI bus requires a dedicated DALI bus power supply to function, the DALI power LED will illuminate solidly to indicate suitable (9-26V) power. The LED will be off for no power or flash to indicate out of range power.

- Ethernet

A standard I0/I00TX Ethernet connection must be made to the RIO. A Power-overEthernet (PoE) switch or midspan injector is required to operate the RIO. The LEDs on the RJ45 jack itself are useful for debugging the Ethernet installation:

The Lnk LED will illuminate when an Ethernet link has been established.

The Dat LED will illuminate to indicate Ethernet traffic (not just Pharos-relevant).

**NOTE:** Ports and third party equipment can be damaged when plugging or unplugging an energised system (hot-plugging). It is therefore advisable to remove power before making or breaking port connections.

## BPS INSTALLATION

The Pharos Button Panel Stations (BPS) are ancillary devices that provide user interfaces to a system. As such, they can not be used on their own but must have at least one Controller present on an Ethernet network to function.

The units are designed to be permanently installed into UK or US single-gang back boxes (supplied separately). The units are 100% solid state and have been qualified to operate in a dry environment within a temperature range of 0°C to 50°C (32°F to 122°F).

The following drawing illustrates a typical installation (UK shown):

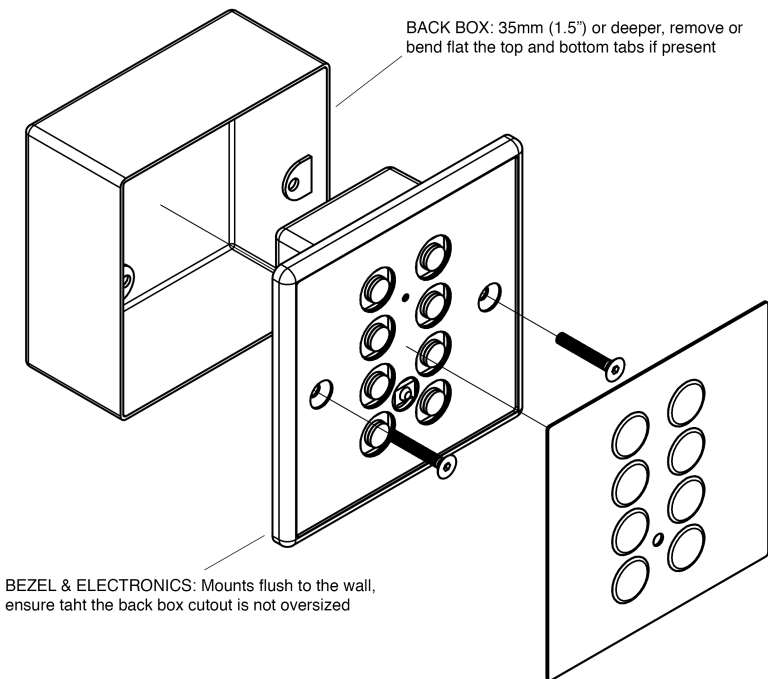

## BPS VERSIONS

There are four versions of the BPS available:

T1 UK: Slimline Aluminium bezel with magnetic overlay, UK single-gang size.

T1 US: Slimline Aluminium bezel with magnetic overlay, US single-gang size.

T2 UK: Customisable acrylic bezel with clear acrylic overlay, UK single-gang size.

T2 US: Customisable acrylic bezel with clear acrylic overlay, US single-gang size.

## BPS LAYOUT

The following drawing illustrates the layout of a Pharos Button Panel Station (UK shown with overlay removed), refer to the following sections for details:

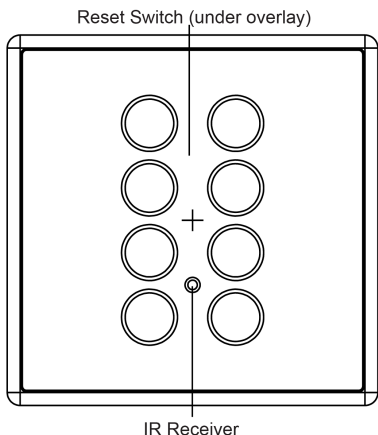

## POWER SUPPLY

- Power-over-Ethernet (PoE)

A standard (802.3af) Power-over-Ethernet switch should be used to provide both power and a network connection to the BPS using a single cable.

Alternatively, if a PoE switch is not available, a PoE midspan injector could be used.

The BPS operates as a PoE Class I device (0.44>3.84W) and will typically consume 1.5W .

**NOTE:** Power must not be disconnected during firmware updates to the BPS as corruption of the software may occur, perhaps even rendering the unit inoperable.

## STATUS LEDS

The LEDs on the rear of the unit provide the following status information:

Pwr: Power - illuminates when the unit is correctly powered.

Act: Active - illuminates once the boot up procedure has completed and is indicative of a fully functional unit.

Net: Network - illuminates when the unit is sending or receiving Pharos-related data.

Lnk: Link - illuminates once the unit has established an Ethernet link.

100: 100BASE-TX - illuminates when the Ethernet link is operating at 100Mbit/s.

## **ERROR CODES**

Additionally the red status LEDs are used to indicate any boot failures of the BPS that prevent the unit from operating. Error codes are displayed by a repeating pattern of flashing both LEDs a number of times in succession, followed by a 1 second pause:

1 flash - Invalid firmware version (reload firmware from Designer)

2 flashes - Invalid device type or serial number

3 flashes - Internal memory test error

4 flashes - Unable to perform factory restore due to corrupt factory firmware

5 flashes - Current firmware is corrupt, no valid firmware versions available to restore

6 flashes - Restored firmware is corrupt

Codes 2 through 6 indicate a hardware error; please consult your distributor, representative or Pharos support for assistance.

## **ADDRESS WHEEL**

Multiple BPSs may be used on a single network. Each BPS is uniquely identified by its address setting.

Wheel settings '1' to '15' directly set the BPS's address to the corresponding number. Up to 15 BPSs may be addressed in this way. For systems with more, the manual ('M') setting should be used to allow identification using the BPS's serial number rather than the address.

## **RESET SWITCH**

The BPS may be reset by removing the magnetic overlay and inserting a small blunt object into the reset hole to depress the reset switch. The switch should be held for at least one second.

**NOTE:** The reset must not be operated during firmware updates to the BPS as corruption of the software may occur, perhaps even rendering the unit inoperable.

## **WATCHDOG**

An internal "watchdog" will automatically reset the BPS in case of a software crash as a result of either a coding error ("bug") or a random electromagnetic event such as a power brown-out or spike, nearby lightning strike or static discharge.



## LEARNING IR RECEIVER

The BPS may be taught to recognise up to 8 different IR codes from a standard infra red remote control. When a key on the remote control is pressed during normal operation, the BPS will react as though one of its 8 buttons has been pressed.

### TO ENTER LEARN MODE:

1. Enter by holding down the bottom two (or only two) buttons while pressing and releasing reset.
  - The buttons will display a clockwise chase sequence.
2. Release the two buttons.
  - Each button will flash quickly (4Hz) if an IR code has been learnt, or slowly (1Hz) if not.
  - No network communication will operate while in Learn Mode.
  - Learn Mode will automatically exit after 60 seconds of inactivity.

### TO LEARN AN IR CODE:

1. Briefly press and release a single button which should learn the IR code
  - The button will start flashing rapidly (8Hz) and the other buttons will extinguish.
2. Within ten seconds, point the IR remote at the BPS and press and hold the desired key.
  - The buttons will display a clockwise chase sequence when the IR code has been learnt.
3. Release the key on the IR remote.
  - The button now will be flashing quickly (4Hz) to indicate that it has an IR code stored.

### TO ERASE AN IR CODE:

1. Press and hold for three seconds the button which should erase its IR code.
  - The buttons will display a clockwise chase sequence when the IR code has been erased.
2. Release the button.
  - The button will now be flashing slowly (1Hz) to indicate that it has no IR code stored.

### TO TEST AN IR CODE:

1. Point the IR remote at the BPS and press and hold the key to test.
  - The button(s) that has learnt this code will illuminate solidly, all others will extinguish.
2. Release the key and test the others.

### TO EXIT LEARN MODE:

1. Press the reset button or wait for 60 seconds.
  - The buttons will now revert to normal operation.
  - Network communication will resume.

Note that the BPS does not have to be part of a networked Pharos system to learn IR codes, all that is required is PoE power and the donor IR remote control.



## POE INSTALLATION

The Pharos 1+4 port Power-over-Ethernet Switch (POE) is designed to be permanently installed in a central control room/cupboard or DIN consumer unit for remote deployment. The enclosure and mounting complies with DIN43880 and EN60715 (35/7.5 rail) respectively.

The unit is 100% solid state and has been qualified to operate in a dry environment within a temperature range of 0°C to 50°C (32°F to 122°F). Sealed IP65 rated consumer units are available for outdoor use, please consult your Pharos distributor or representative.

## POE LAYOUT

The following drawing illustrates the layout of the Pharos POE Switch, refer to the following sections for details:

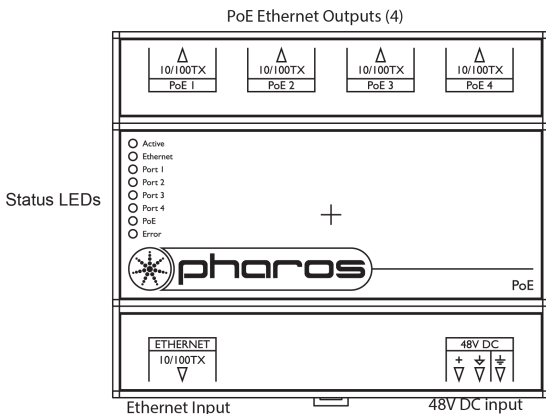

## POWER SUPPLY

- DC power (48V)

A limited power source approved to UL60950-1 2 Edition, CAN/CSA C22.2 No. 60950nd1.07 2 Edition MUST be used, with an output voltage of 48V DC.

Such a power supply can be connected directly to the POE using the DC Input connector. The pins on this connector are marked:

- + Positive input (9 to 48V DC)
- ↓ Signal ground (0V)
- ⊥ Chassis ground (earth)

The power supply should be connected to the Positive and Signal ground inputs, ensuring the polarity is correct.

## **POWER SUPPLY CHOICE & POE LOADING**

The choice of power supply, in terms of its power rating, depends on the intended loading of the four PoE ports.

If the intention is to supply four Class 1 devices (for example RIO or BPS) then a 24W (48V @0.5A) supply will suffice.

If, however, the intention is to supply four Class 2 devices (for example LPC) then a 48W (48V @ 1A) supply will be required.

Multiple POEs may be powered by a single power supply provided its rating is increased accordingly.

## **GROUNDING**

The POE is designed to be mounted on a grounded (earthed) DIN-rail and a dedicated Chassis ground (earth) terminal is also provided which should be connected to a suitable earth.

## **STATUS LEDS**

The Pharos logo will illuminate when power is applied to the POE. The red LEDs on the top of the POE indicate the unit's status:

- Active: Indicates that the unit is functional.
- Ethernet: Illuminates when the link has been established and toggles off to indicate data.
- Port 1-4: Illuminates when the link has been established and toggles off to indicate data.
- PoE: Indicates that one or more of the ports is supplying PoE power.
- Error: Flashes to indicate an error condition.

## RDM INSTALLATION

The Pharos 1+4 port DMX512 Repeater (RDM) is designed to be permanently installed in a central control room/cupboard or DIN consumer unit for remote deployment. The enclosure and mounting complies with DIN43880 and EN60715 (35/7.5 rail) respectively.

The unit is 100% solid state and has been qualified to operate in a dry environment within a temperature range of 0°C to 50°C (32°F to 122°F). Sealed IP65 rated consumer units are available for outdoor use, please consult your Pharos distributor or representative.

## RDM LAYOUT

The following drawing illustrates the layout of the Pharos DMX Repeater, refer to the following sections for details:

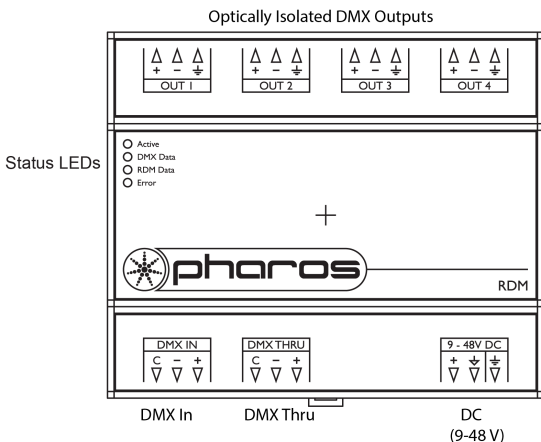

## POWER SUPPLY

- DC power (9 to 48V)

A limited power source approved to UL60950-1 2 Edition, CAN/CSA C22.2 No. 60950nd1.07 2 Edition MUST be used, with an output voltage of 9 to 48V DC.

Such a power supply can be connected directly to the RDM using the DC Input connector. The pins on this connector are marked:

- + Positive input (9 to 48V DC)
- ⚡ Signal ground (0V)
- ⊥ Chassis ground (earth)

The power supply should be connected to the Positive and Signal ground inputs, ensuring the polarity is correct.

The RDM will typically consume 4W with all ports fully loaded.

## **GROUNDING**

The RDM is designed to be mounted on a grounded (earthed) DIN-rail and a dedicated Chassis ground (earth) terminal is also provided which should be connected to a suitable earth.

## **STATUS LEDS**

The Pharos logo will illuminate when power is applied to the RDM. The red LEDs on the top of the RDM indicate the unit's status:

Active: Indicates that the unit is functional.

DMX data: Illuminates when DMX data is being routed (input to all ports).

RDM data: Illuminates when RDM data is being routed (a port to input).

Error: Flashes to indicate an error condition.

## **DMX THRU TERMINATION**

If the DMX Thru connection is not being used to daisy-chain to other DMX devices then the supplied termination resistor **MUST** be fitted to ensure data integrity.

## **DMX & RDM GUIDELINES**

The RDM is compatible with the DMX512, DMX512(1990), DMX512-A and RDM 1.0 standards and care should be taken to ensure that your cabling, wiring topology and termination also complies with these standards.

Such compliance is beyond the scope of this document but a good resource is "Recommended Practice in DMX 512" by Adam Bennette which is available through PLASA and USITT .

## CXD INSTALLATION

The Pharos LED Drivers (CxD) are ancillary devices that provide direct LED control. As such, they can not be used on their own but must have at least one Controller (LPC 1/2/4) or Remote Input/Output Device (RIO 80/44/08) present to provide the DMX control data.

The units are designed to be permanently installed in a central control room/cupboard or DIN consumer unit for remote deployment. The enclosure and mounting complies with DIN43880 and EN60715 (35/7.5 rail) respectively.

The units are 100% solid state and have been qualified to operate in a dry environment within a temperature range of 0°C to 50°C (32°F to 122°F). Sealed IP65 rated consumer units are available for outdoor use, please consult your Pharos distributor or representative.

## CXD LAYOUT

The following drawing illustrates the layout of the Pharos CxD, refer to the following sections for details:

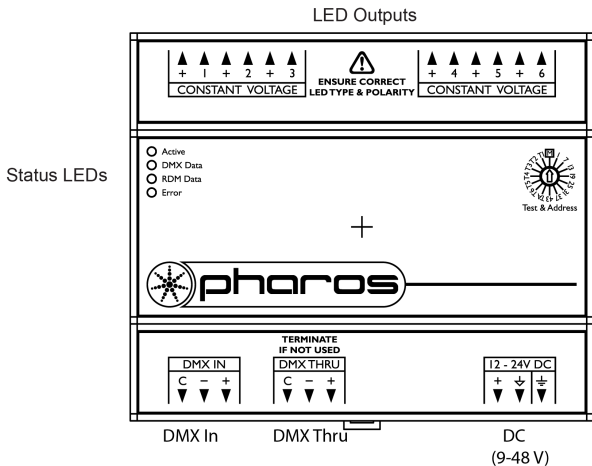

## CXD VERSIONS

There are four versions of the CxD available:

- CVD: 6 channel constant voltage LED driver (shown above), 12-24V DC input.
- CCD 350: 6 channel constant 350mA current LED driver, 15-48V DC input.
- CCD 500: 6 channel constant 500mA current LED driver, 15-36V DC input.
- CCD 700: 6 channel constant 700mA current LED driver, 15-24V DC input.



## POWER SUPPLY

- DC power (12 to 48V dependant on version and LED loading)

A limited power source approved to UL60950-1 2 Edition, CAN/CSA C22.2 No. 60950nd1.07 2 Edition MUST be used, with an output voltage of 12 to 48V DC.

Such a power supply can be connected directly to the CxD using the DC Input connector . The pins on this connector are marked:

- + Positive input (9 to 48V DC)
- ⚡ Signal ground (0V)
- ⊕ Chassis ground (earth)

The power supply should be connected to the Positive and Signal ground inputs, ensuring the polarity is correct.

The CxD will consume 200W maximum with all channels fully loaded at full intensity.

## GROUNDING

The CxD is designed to be mounted on a grounded (earthed) DIN-rail and a dedicated Chassis ground (earth) terminal is also provided which should be connected to a suitable earth.

## STATUS LEDS

The Pharos logo will illuminate when power is applied to the CxD. The red LEDs on the top of the CxD indicate the unit's status:

- Active: Indicates that the unit is functional.
- DMX data: Illuminates when DMX data is being received.
- RDM data: Illuminates when RDM data is being transmitted.
- Error: Flashes to indicate an error condition.

## DMX THRU TERMINATION

If the DMX Thru connection is not being used to daisy-chain to other DMX devices then the supplied termination resistor MUST be fitted to ensure data integrity.

## DMX & RDM GUIDELINES

The CxD is compatible with the DMX512, DMX512(1990), DMX512-A and RDM 1.0 standards and care should be taken to ensure that your cabling, wiring topology and termination also complies with these standards.

Such compliance is beyond the scope of this document but a good resource is "Recommended Practice in DMX 512" by Adam Bennette which is available through PLASA and USITT .

## TEST & ADDRESS WHEEL

Wheel settings '1' to '43' directly set the CxD's DMX start address to the corresponding channel number. Alternatively, use the managed ('M') setting to set the DMX start address via the RDM protocol (see Designer Help for details) in which case the CxD can be addressed to any DMX channel number.

Wheel settings 'T1' to 'T6' and 'TA' provide test facilities for the installer by bringing the corresponding channel or all channels to 25%. The DMX control data is ignored when testing channels in this way. Note that there is a small delay (0.5sec) in the response of the wheel to avoid intermediate settings taking effect.

## LED FIXTURE TYPES (LOW VOLTAGE ARCHITECTURAL ONLY)

LED fixtures are totally unlike conventional lighting fixtures due to the behaviour of the semiconducting Light Emitting Diode (LED) itself:

- Correct polarity must be observed to avoid “breakdown”
- Specified forward voltage ( $V_f$ ) must at least be applied (the LED will “drop”  $V_f$ )
- Specified drive current ( $I_f$ ) must be carefully maintained
- Dimming is achieved by “chopping” the drive current, typically by PWM
- Thermal management is critical for long life and reliability, choose your fixtures well

LED fixtures typically comprise either one or more LEDs in a module (“light engine”) or as an array on a substrate, commonly a flexible “tape” that can be cut to the desired length. This is the first important distinction to make since the former require a constant current driver (the fixture is just LEDs) and the latter a constant voltage driver (the fixture includes current control electronics):

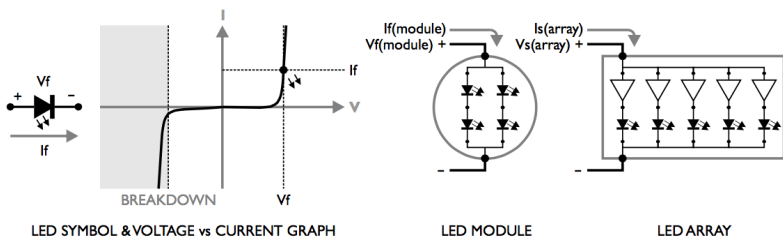

So before you can select the correct LED driver you must determine the fixture type and then gather the drive characteristics from the manufacturer:

### LED MODULE - CONSTANT CURRENT DRIVE

- Module forward current  $I_f(\text{module})$  which is typically 350, 500 or 700mA
- Module forward voltage  $V_f(\text{module})$  which is module power divided by  $I_f(\text{module})$

### LED ARRAY - CONSTANT VOLTAGE DRIVE

- Array supply voltage  $V_s(\text{array})$  which is typically 12 or 24V
- Array power dissipation  $P_s(\text{array})$  which is determined by its size/length (eg. Watt/metre)

Colour changing fixtures just have multiple instances of these LED arrangements, one for each colour, typically three (RGB) so requiring three driver/DMX channels to control. Note that with colour changing LED fixtures the anodes (+) are connected together and the cathodes (-) individually driven since LED current switching occurs on the negative side. Beware colour coded cables as there is no standard coding system.

## **FIXTURE GANGING**

It is often desirable to gang fixtures together onto one driver/DMX channel and here again the fixture type determines how this is done and what needs to be determined:

### **LED MODULE - GANG IN SERIES**

- All modules must have the same forward current  $I_f(\text{module})$  to be ganged
- Determine the total forward voltage drop  $V_f(\text{total})$  by summing the  $V_f(\text{module})$ s
- It is helpful to end up with similar  $V_f(\text{total})$ s for each gang of arrays

### **LED ARRAY - GANG IN PARALLEL**

- All arrays must have the same supply voltage  $V_s(\text{array})$  to be ganged
- Determine the total power load  $P_s(\text{total})$  by summing the  $P_s(\text{array})$ s
- It is helpful to end up with similar  $P_s(\text{total})$ s for each gang of arrays

## **CXD VERSION & POWER SUPPLY SELECTION**

Once you have determined the fixture types, drive characteristics and ganging requirements you can select the appropriate drivers & power supplies:

### **LED MODULE - GANG IN SERIES - CONSTANT CURRENT**

- Use the CCD 350, 500 or 700 for 350, 500 or 700mA  $I_f(\text{module})$  drive respectively
- Choose a power supply such that  $V_{in}$  is slightly greater (2-3V) than the maximum  $V_f(\text{total})$
- The more that  $V_{in}$  exceeds  $V_f(\text{total})$  per channel then the worse the efficiency

### **LED ARRAY - GANG IN PARALLEL - CONSTANT VOLTAGE**

- Use the CVD ensuring that each channel load is 40W maximum or 180W in total
- Choose a power supply such that  $V_{in}$  equals  $V_s(\text{array})$
- Choose a power supply capable of supplying the total load, sum of each  $P_s(\text{total})$
- Long cables decrease efficiency, split up large arrays to avoid visible drooping

That all being said, ganging is an iterative process based on zoning requirements and driver & power supply choices with the highest system efficiency and lowest cost being the overall target. It is often sensible to start with the constant voltage power supply requirement and use that for

the constant current supply as well to standardise on a power supply but this is not a requirement. You should also not balk at selecting the LED fixtures themselves to fit into your overall system.

Further, consider distributing the LED drivers & power supplies to be close to the fixtures themselves to minimise cabling and cable losses (constant voltage) and maximise flexibility, particularly when it comes to refits. Finally it is advisable to use multiple low-power power supplies, perhaps one per 6 channel driver, rather than a centralised high-power approach.







## WARRANTY

This Pharos Architectural Controls Limited (“Pharos”) product is warranted for the period of five (5) years from the original date of purchase against defective materials and workmanship.

In the event that warranty service is required, you should contact your dealer or Pharos technical support at the following email address: support@pharoscontrols.com.

## CONDITIONS

1. The warranty is only valid if the Pharos Designer software registration is fully and properly completed, Pharos is presented with the original invoice or sales confirmation, Pharos has received payment in full and the serial number on the product has not been defaced.
2. Pharos' obligations are limited to the repair or, at its discretion, replacement of the product or the defective part.
3. It is the consumer's obligation to notify Pharos within one week of any suspected defect, and to return the goods prepaid to Pharos' authorized service address. Goods will only be received under warranty when they are returned with a recognised RMA number that has been issued by Pharos.
4. Warranty repairs must be carried out by a nominated Pharos employee or Pharos approved service technician. No reimbursement will be made for repairs carried out by non-Pharos personnel or dealers, and any such repair work or damage to the product caused by such repair work will not be covered by this warranty.
5. This product is not considered to be defective in materials or workmanship by reason that it requires adaptation in order to conform to national or local technical or safety standards in force in any country other than the one for which the product was originally designed or manufactured. This warranty will not cover, and no reimbursement will be made for such adaptation or any damage which may result.
6. This warranty covers none of the following:
  - a. Maintenance and repair or replacement of parts due to normal wear and tear.
  - b. Cost relating to transport, removal or installation of the product.
  - c. Misuse, including the failure to use this product for its normal purposes or incorrect installation.
  - d. Damage caused by lightning, water, fire, acts of God, war, public disturbances, incorrect supply voltage, improper ventilation or any other cause beyond the control of Pharos.
7. This warranty is valid for any person who legally acquired possession of the product during the warranty period.
8. The consumer's statutory rights in any applicable national legislation arising from the purchase are not affected by this warranty. The rights under this warranty are the consumer's sole rights and Pharos, its subsidiaries or distributors shall not be liable for any indirect or consequential loss, damages for any loss of use, time, profits or income, or any damage to related equipment, materials or consumable parts.

## COMPLIANCE

The Pharos Architectural Controls Limited product range is manufactured to the highest quality in compliance with the following international standards:

## ENCLOSURE AND MOUNTING

- EN60715: Top hat section (TH) 35-7.5mm & 35-15mm DIN rail.
- DIN 43 880: Built-in equipment for electrical installations; Frame size I.
- IEC 60297: 2U 19" rack mounting enclosure.
- IP40 rated.

## ELECTROMAGNETIC COMPATIBILITY

- 2014/30/EU (EMC)
- 2006/95/EEC (LVD)

## SAFETY

- UL 60950-1 2nd Edition & CAN/CSA C22.2 No. 60950-1.07 2nd Edition.

## ENVIRONMENTAL

- 2011/65/EEC (RoHS)
- 2012/19/EU (WEEE)

