

## µDim Microwave 1-10V Sensor



The SL-MW-AN miniature microwave presence detector provides automatic control of lighting loads. The unit comes complete with a flush-mount bracket, allowing unobtrusive mounting of the sensor head into ceiling tiles or onto solid surfaces. It has been designed so that it can be used for luminaire mounted or ceiling mounted applications. As microwave radiation penetrates plastic and glass, this unit has been specifically designed to be mounted inside a luminaire.

The product consists of the following :

- Sensor head with integral RJ11 sensor lead
- Power supply unit
- Flush mount bracket

Presence detection: when movement is detected the load will automatically turn on; when the area is no longer occupied the load will automatically switch off after an adjustable time period.

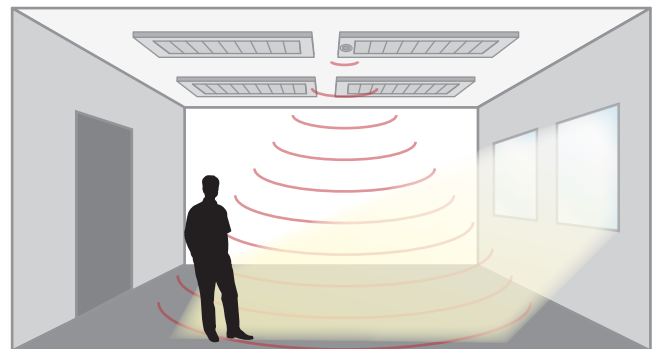

3) Presence detected some daylight.  
Lights on and dimmed to maintain lux level

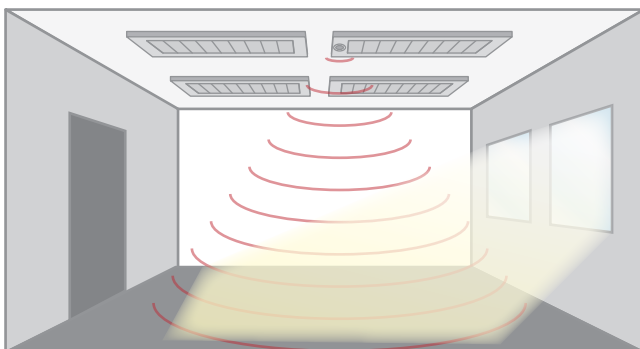

1) No presence detected, daylight, lights OFF

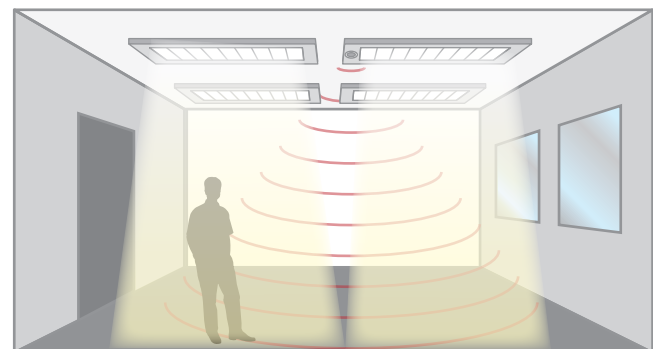

4) Presence detected, insufficient daylight. Detector measures and implements maintained illuminance

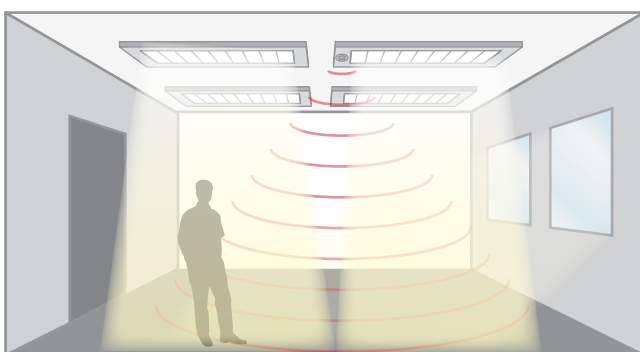

2) Presence detected, sufficient daylight, lights OFF

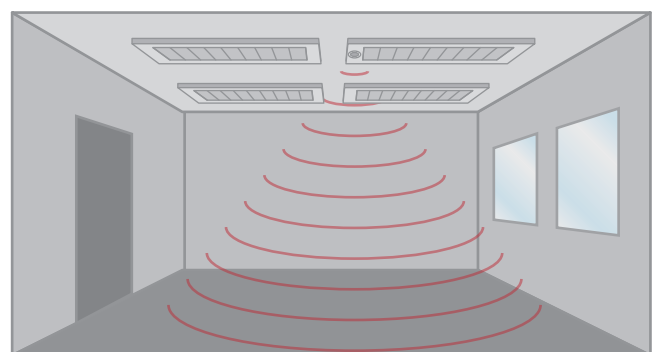

5) No presence detected, night time, lights OFF

## µDim Microwave 1-10V Sensor

### Technical specifications

- Supply voltage 220 - 240 V AC, 50 Hz
- Max load capacity Relay Output - 2 A  
Dimmed Output - 4 x 1-10V ballasts
- Light level Light to dark
- Connections Integral RJ11 cable between supply unit and sensor head
- Terminals (supply unit) 1.5mm<sup>2</sup> (solid core cable only)

### Material

- Sensor head, surface mount baseplate , flush bracket — Flame retardant ABS
- Flange mount bracket & Lens—PMMA (Clear acrylic)
- Power supply unit housing — Flame retardant polycarbonate

- Type Class 2
- Operating Temperature -10°C to 50°C

### SAFETY

The microwave radiation emitted by these units is extremely low power. At a distance of > 50mm the power density is <6% of the ANSI IEEE C95.1 -1991 recommended microwave power density. At a distance of 5mm from the unit it is <84% of recommended power density.

- Conformity** EMC-89/336/EEC  
LVD-73/23/EEC

### Detection area

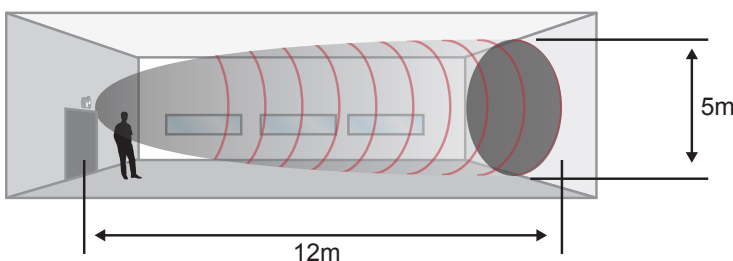
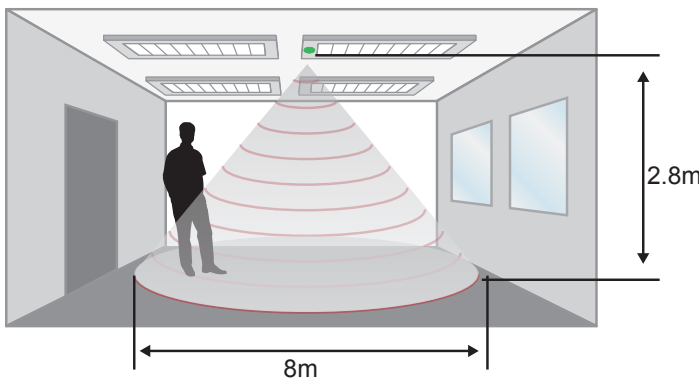

### Sensor head

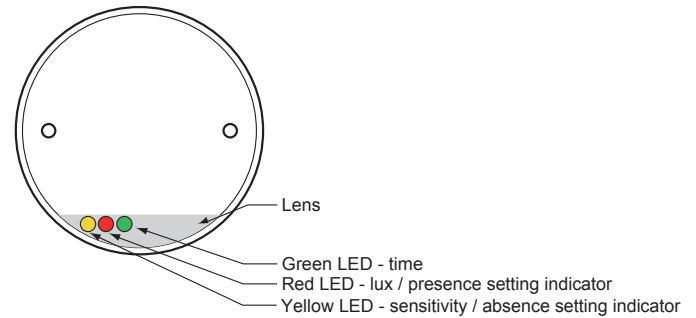

### Recommended mounting location

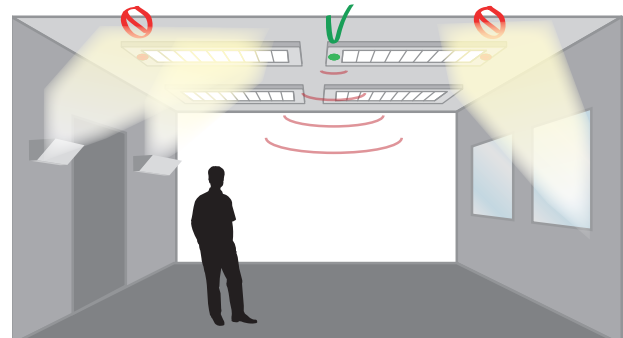

- Avoid direct sunlight entering the sensor
- Do not site within 1m of forced air heating or ventilation.
- Do not fix to a vibrating surface.
- Avoid metallic objects directly in front of the sensor head.
- Do not fit to a suspended luminaire
- When installing the sensor head behind a glass / polycarbonate diffuser will reduce the detection range by approximately 20%.

**Note:** On maximum sensitivity, the detector unit is extremely sensitive to movement and may detect through glass, thin walls or partitions. If this causes a problem, reduce its sensitivity using the SA-IR-PROG Programmer.

Dimensions

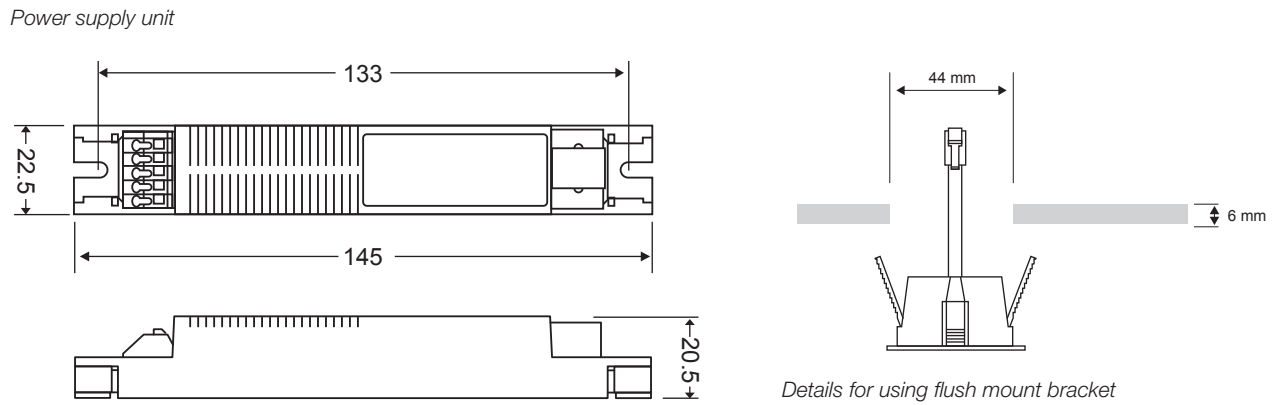
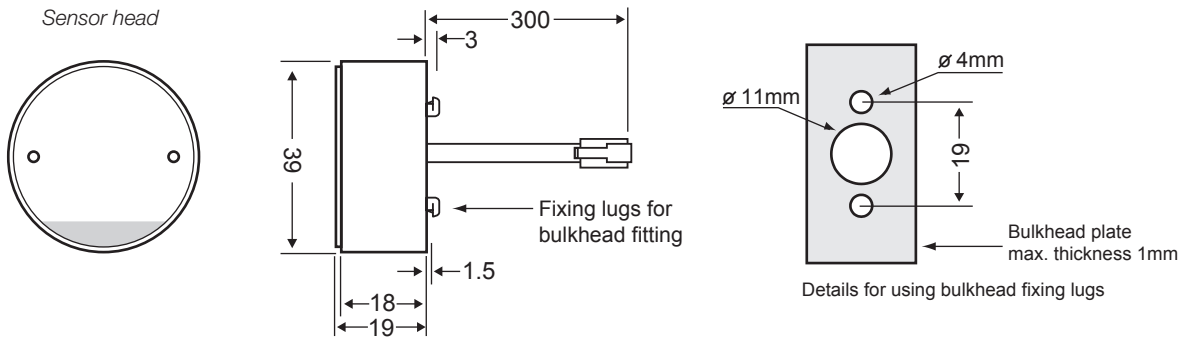

Connections

