

Transistor Dimmer (454)

The DIN-rail mounted 454 is a four-channel transistor dimmer. It can operate in one of two modes: leading edge or trailing edge. All four channels operate in the same selected mode, with each channel capable of controlling 2.2 A.

It supports capacitive and resistive loads, and it can be connected directly to mains-voltage lamps and to low-voltage lamps with electronic transformers. The 454 is not for use with inductive loads.

Each channel of the dimmer has both current and thermal protection.

The dimmer features an LED segment display. There is a push button user interface for monitoring, manual configuration and control purposes.



Key Features

- Trailing-edge or leading-edge dimming
- LED segment and push buttons for manual configuration, including the following output types: linear, square, S-law, DALI logarithmic, LED curve, and DALI linear
- Capable of handling resistive and capacitive loads
- Manual wired override input
- Voltage and frequency compensation
- Overcurrent and temperature protection included
- Power-on to last level or to user-defined level

Additional Features

The following features may be accessed using the Toolbox or Designer software:

- Max./Min. levels, fade times, scenes and groups
- System failure level/ignore

Output	Output Type	Additional Information
⌚ 0	Non-Dim	Switched on and off only
⌚ 1	Linear	Optimised for incandescent
⌚ 2	Square	Optimised for incandescent
⌚ 3	S-law	Optimised for incandescent
⌚ 4	DALI logarithmic	IEC 62386-205
⌚ 5*	LED curve	Optimised for LED
⌚ 6	DALI linear	IEC 62386-205

Note:

* ⌚ 5 is the default output type.

Connections

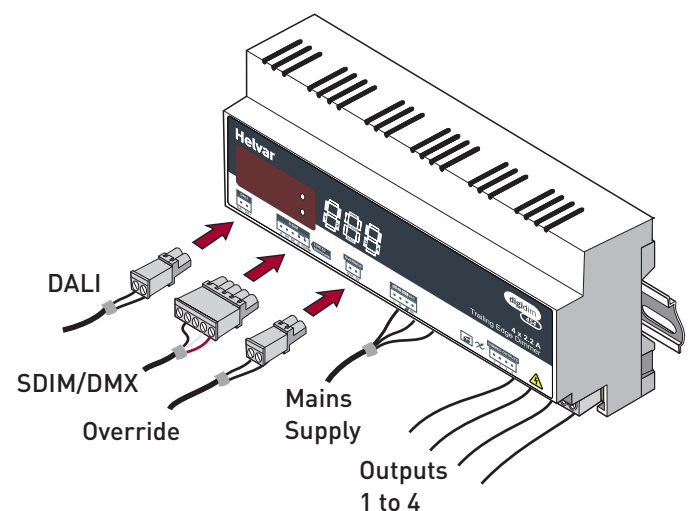

Technical Data

Connections

Mains:	Solid core: up to 4 mm ² Stranded: 2.5 mm ² <i>Note: Functional earth connection used for DALI/SDIM/DMX screens only.</i>
DALI:	0.5 mm ² – 1.5 mm ² , max. 300 m @ 1.5 mm ²
SDIM/DMX:	0.22 mm ² – 1.5 mm ² low-loss RS485 type (multistranded, twisted and shielded)

Power

Mains supply:	100 VAC – 240 VAC (nominal) 85 VAC – 264 VAC (absolute) 45 Hz – 65 Hz
Power consumption:	2.3 W (excluding loads)
Load current:	2.2 A (2.2 A × 230 V = 500 W) 4 outputs (4 × 500 W = 2 kW)
Heat dissipation:	11 W with maximum load (resistive)
DALI consumption:	2 mA
External protection:	10 A Type C MCB maximum. The external supply must be protected.

Inputs

Communication:	DALI, SDIM and DMX
Override:	Switched input
User interface:	2 push buttons for configuration

Mechanical data

Dimensions:	160 mm × 91 mm × 62 mm
Housing:	DIN-rail case; 9 module width
Material:	Polycarbonate/ABS mix, UL94 V-0
Mounting:	DIN rail mounting
Weight:	250 g
IP code:	30 (IP 00 at terminals)

Operating conditions

Ambient temperature:	0 °C to +40 °C
Relative humidity:	Max. 90 %, noncondensing
Storage temperature:	-10 °C to +70 °C

Conformity and standards

DALI:	DALI standard IEC 62386, with Helvar additions
SDIM:	Helvar SDIM protocol
DMX:	DMX512-A protocol (max. refresh rate: 33 Hz)
EMC emission:	EN 55015
EMC immunity:	EN 61547
Safety:	EN 60950
Environment:	Complies with WEEE and RoHS directives.

Dimensions (mm)

