

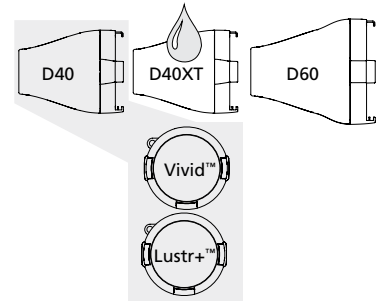

100V 115/120V 230/240V



This datasheet covers D40 fixtures as shown. See other datasheets for other versions.

GENERAL INFORMATION

The ETC Selador® Desire D40 fixture puts the seven-color x7 system into a round theatrical washlight. Highly efficient primary lenses and careful color choices make the D40 fixture ideal for stage, studio and anywhere strong color and high-intensity are requirements. The Selador x7 Color System™ produces the widest range of spectrally-balanced saturated and tinted color choices available. D40's rugged die-cast enclosure, noiseless fan-free operation, multiple lens options and advanced user interface make it ideal for multiple applications.

D40 LED ARRAY OPTIONS

D40 fixtures are based on the x7 Color System which uses seven different LED colors to achieve true, usable broad-spectrum color. The D40 luminaire is available with any one of the following x7 color arrays (not interchangeable) to best suit the intended application:

- D40 Vivid – the x7 Color System array balanced for best all-around use as a high-intensity color-changing wash fixture
- D40 Lustr+ – optimized array with six colors plus high-intensity white LEDs to create an ideal frontlight wash fixture for full-range color, with an emphasis on lighter colors and white. It naturally lights skin tones

ORDERING INFORMATION

Selador D40

MODEL	DESCRIPTION
SELD40VI	D40 Vivid
SELD40LI	D40 Lustr+

Note: D40 luminaires ship with a hanging yoke and an input lead with connector of choice. See page 2 for connector options. C-clamps are not included.

SELD40 V I - 0X

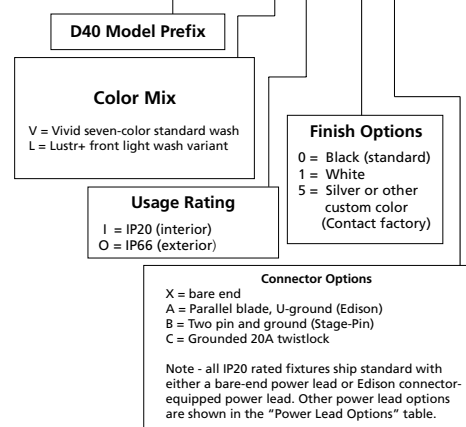

Note - all IP20 rated fixtures ship standard with either a bare-end power lead or Edison connector-equipped power lead. Other power lead options are shown in the "Power Lead Options" table.

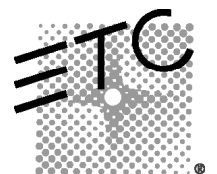

SPECIFICATIONS

**GENERAL**

- 40-LED color-mixing wash fixture
- ETL Listed to UL1573 – the standard for stage and studio lighting units
- IP20-rated for indoor use
- Power and DMX in/thru connections for easy setup
- User-friendly control interface with multiple modes and fixture settings

**PHYSICAL**

- Rugged die-cast all-metal housing
- Easy access slots for secondary lenses and standard 7.5" PAR accessories
- Available in black (standard), white or silver (optional) or custom colors (contact factory)
- Hanging yoke standard. Optional yoke/floor stand available

**ELECTRICAL**

- 100VAC to 240VAC 50/60Hz universal power input
- Neutrik power in and thru connections
- Up to nine fixtures (15A max) may be linked via power thru connector (10 fixtures total per circuit) when used with R20 Relay Module or Unison Echo Relay Panel. Consult breaker trip curves when used with other equipment
- Requires power from a non-dim source
- Inrush
  - 120V / 15A (First half-cycle)
  - 240V / 40A (First half-cycle)

**LED\***

- 50,000-hour LED life (50,000 hours to 70% intensity)
- 40 Luxeon® Rebel LED emitters

\*See additional LED notes on page three

**COLOR**

- Exclusive x7 *Color System*™ seven-color LED array
- Beautifully illuminates skin tones and other objects for natural appearance and high color rendering
- Broad-spectrum color interacts seamlessly with conventional sources
- Exclusive optional red-shift option emulates tungsten dimming performance
- Variable color temperature from 2700K-6500K

**OPTICAL**

- Primary field angle of 22° and beam angle of 10.5°
- Secondary lenses available for multiple beam-spread options
- Additional lenses must be ordered separately
- Refer to accessories charts for lenses available

**CONTROL**

- DMX512 in and thru via five-pin XLR connectors
- Multiple control options including RGB, strobe, and console-free Master/Slave mode
- See DMX control table for additional information
- 15-bit virtual dimming engine provides smooth, high-quality theatrical fades and minimizes color shift during dimming
- RDM functionality for address and setting changes

SPECIFICATIONS

**THERMAL**

- Ambient operating temperature of -4° to 104°F (-20° to 40°C)
- Active electronic thermal management for droop-free operation
- Noiseless, fan-free convection cooling for acoustically sensitive installations
- Fixture is designed for continuous operation up to 104°F (40°C) ambient temperature and requires free flow of air around fixture housing

ADDITIONAL ORDERING INFORMATION

**Power Input Cables**

Use information below to order 5' power input leads with factory-fitted connectors

MODEL	DESCRIPTION
DPA-A	5' PowerCon™ to parallel blade U-ground (Edison) connector
DPA-B	5' PowerCon to 20A two-pin and ground (stage pin) connector
DPA-C	5' PowerCon to grounded 20A twistlock connector
DPA-X	5' PowerCon to bare-end power input lead

**Power Thru Jumpers**

Note: Power thru jumpers connect to fixture's output (thru) connector to provide link to successive fixtures

MODEL	DESCRIPTION
DPJ-5	5' PowerCon to PowerCon™ fixture to fixture jumper
DPJ-10	10' PowerCon to PowerCon fixture to fixture jumper

**Fixtures Accessories**

MODEL	DESCRIPTION
SELD40FSY	Yoke with floor-stand attachment
400BD	Barn door (Use only as a flexible top hat to diminish aperture glare. Not for beam shaping)
407CF	Color Frame (use for round and oblong lenses)
400L	Egg Crate Louver
400PTH3	Top Hat 3" Tube
400PTH6	Top Hat 6" Tube
400PHH	Half Hat 6" Tube
400CC	C-Clamp (does not ship with fixture)
400SC	Safety Cable (32")
DPSJ-25	25' PowerCon to Edison input power cable with inline switch

ADDITIONAL ORDERING INFORMATION

Secondary Lens Options

MODEL	DESCRIPTION: The following lenses are cut for D40 fixtures and create round, linear or oblong field patterns as described below. These lenses are not sized for use in Selador Classic™ fixtures.	
<b>Narrow Linear Field</b>	Note: This is the same material as Selador Classic lenses	
SELLVN-7.5	7.5" Very Narrow lens	Linear lenses may be combined to create desired field size
SELLN-7.5	7.5" Narrow lens	
SELLM-7.5	7.5" Medium lens	
SELLW-7.5	7.5" Wide lens	
SELLEW-7.5	7.5" Extra Wide lens	
<b>Round Field</b>		
SELRVN-7.5	7.5" Very Narrow lens (round field)	
SELRN-7.5	7.5" Narrow lens (round field)	
SELRM-7.5	7.5" Medium lens (round field)	
SELRW-7.5	7.5" Wide lens (round field)	
<b>Oblong Field</b>		
SELON-7.5	7.5" Narrow lens (oblong field)	
SELOM-7.5	7.5" Medium lens (oblong field)	
SELOW-7.5	7.5" Wide lens (oblong field)	

[http://www.etconnect.com/docs/docs\\_downloads/miscdocs/Desire vs PAR EA revB.pdf](http://www.etconnect.com/docs/docs_downloads/miscdocs/Desire_vs_PAR_EA_revB.pdf)

Typical Lens Field Profiles

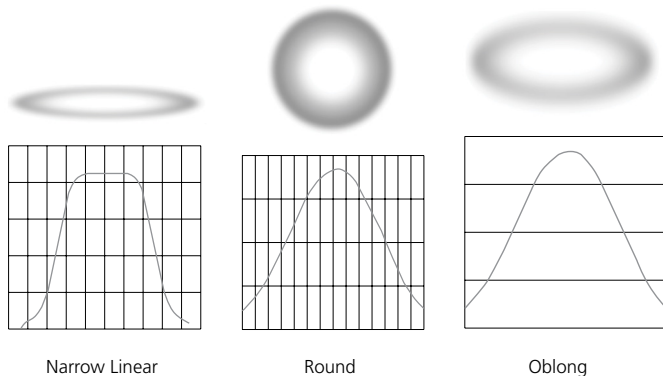

Power Consumption at Full Intensity

MODEL	VOLTAGE (V)	CURRENT (A)	WATTS
D40	120 / 240	1 / 0.5	110

NOTES ABOUT LED LUMINAIRES

All LED sources experience some lessening of light output and some color shift over time. LED output will vary with thermal conditions. Thermal conditions can be affected by ambient temperatures and orientation. See the D40 Ambient Temperature and Power Budgeting Guide for more details. Based on the LED manufacturer's B50 L70 specification, a Selador luminaire will achieve ~70% of its initial output after 50,000 hours of typical usage. In individual situations, LEDs will be used for different durations and at different levels. This can eventually lead to minor alterations in color performance, necessitating slight adjustments to presets, cues or programs.

CRI AND CQS RATINGS

Desire fixtures were evaluated for CRI and CQS performance using measured output spectrum and optimized mix solutions for a best spectral match to black body sources at 3200K and 5600K.

Fixture	CRI	CQS	Color Fidelity	Duv
D40 Vivid at 3200K	87	89	89	0.000
D40 Vivid at 5600K	90	92	92	0.000
D40 Lustr+ at 3200K	86	88	88	0.000
D40 Lustr+ at 5600K	93	92	90	0.000
D40 Studio HD at 3200K	89	90	91	0.000
D40 Studio HD at 5600K	92	94	94	0.000
D40 Studio Daylight at 5600K	71	70	69	0.001
D40 Studio Tungsten at 3000K	86	86	86	0.001

All D40 luminaire versions provide excellent color rendering to the eye, particularly at higher color-temperature settings, such as 5600K. In most cases, the Duv is 0.000. A Duv rating of 0.000 indicates that the color mix used is exactly on the black body line, with no green or magenta tint.

## LENS INFORMATION

## Desire diffusion angle measurements

NOMINAL									
	No Lens	Very Narrow	Narrow	Medium	Wide	Extra Wide	Narrow Oval	Medium Oval	Wide Oval
<b>D40</b>		25°	35°	45°	75°	N/A	20° x 40°	30° x 70°	35° x 80°
<b>LUSTR+</b>	22	26	32	54	77	97	29 x 43	33 x 63	33 x 97
<b>VIVID</b>	22	26	32	54	77	97	29 x 43	33 x 63	33 x 97
<b>STUDIO HD</b>	22	26	32	54	77	97	29 x 43	33 x 63	33 x 97
<b>STUDIO D</b>	31	33	38	60	81	97	36 x 48	41 x 68	35 x 97
<b>STUDIO T</b>	31	33	38	60	81	97	36 x 48	41 x 68	35 x 97

Values in black refer to old lens descriptions.

CONTROL OPTIONS

User settings on D40 fixtures allow multiple operational modes and settings for either console operation via DMX protocol or stand-alone operation. The expanded LCD display provides easy navigation to all possible settings and options. Some of the setting options are:

- Multiple DMX choices ranging from a simple RGB profile – which effectively controls all seven LED colors via three channels – to nine-channel ‘direct’ color and intensity control
- Multiple dimming curve options
- Preset colors and sequences for stand-alone (no console required) operation
- White point selection – white light and color behavior based on a specific color-temperature white light, i.e. 3200K, 5600K, etc.
- Loss of data behavior options – instant off, hold last look for two minutes, etc.
- Output modes – three output options that offer the user a choice between maximum output and maximum consistency

See the user manual for a complete explanation of all of the control settings and options for the D40.

Quick Setups

To assist in managing the numerous control and fixture behavior choices, five combinations of operational settings are available to quickly get started. These settings are specifically created for different applications and are easily accessible at the fixture display. Each setting can then be modified as required to take advantage of all of the possible control features.

Setting Title	Profile	Description	Typical Features*
General	Direct	Factory default: For general-purpose use including interior architectural applications	<ul style="list-style-type: none"> <li>• Standard dimming curve</li> <li>• Regulated output for color consistency</li> </ul>
Stage	HSI Plus 7 Enabled	Theatrical lighting: Duplicates the color and dimming behavior of tungsten stage-lighting fixtures	<ul style="list-style-type: none"> <li>• Incandescent dimming curve</li> <li>• Regulated output for color consistency</li> <li>• 3250K white-point setting</li> </ul>
XT Arch	HSI	Exterior architectural lighting: Provides a high degree of color consistency in high ambient-temperature environments	<ul style="list-style-type: none"> <li>• Standard dimming curve</li> <li>• Protected output</li> <li>• 3200K white-point setting</li> </ul>
High Impact	RGB	Event lighting: Enables quickest response, simple RGB control and strobe channel for maximum effect usage	<ul style="list-style-type: none"> <li>• Quick dimming curve</li> <li>• Boost mode for maximum intensity</li> <li>• 5600K white-point setting</li> </ul>
Studio	Studio	Studio factory default: Enables three parameter control of white light (intensity, white point, and tint) via DMX from a console or console-free from a fixture display.	<ul style="list-style-type: none"> <li>• Linear dimming curve</li> <li>• Regulated output mode for color consistency</li> </ul>

\*See user manual for complete list of features for each Quick Setup

CONTROL OPTIONS

DMX Input Channel Profiles

DMX Profile	DMX Channels	Channel Assignments	Notes
Direct	9	1 – Red 2 – Orange (white if Lustr+) 3 – Amber 4 – Green 5 – Cyan 6 – Blue 7 – Indigo 8 – Intensity 9 – Strobe	Direct control of each individual color with a separate master intensity channel. Color calibration of LEDs is not active in this mode. The nine-channel profile will produce the highest-quality color crossfades
HSI	5	1 – Hue (coarse) 2 – Hue (fine) 3 – Saturation 4 – Intensity 5 – Strobe	High-resolution hue (two channels), saturation, and intensity control. HSI mode will produce color crossfades around the color space
HSIC	6	1 – Hue (coarse) 2 – Hue (fine) 3 – Saturation 4 – Intensity 5 – Strobe 6 – Color Point (CCT)	High-resolution hue, saturation and intensity control as above, with the addition of a color point channel to adjust the color temperature of the fixture in both white light and color. Color crossfade performance is the same as HSI
RGB	5 (Ch. 4 not used)	1 – Red 2 – Green 3 – Blue 4 – n/a 5 – Strobe	Effectively addresses all seven colors via three channels of control. RGB profile will produce medium-quality color cross-fades
Studio	3	1 – Intensity 2 – Color Point (CCT) 3 – Tint	Controls fixture as a white light unit. If no DMX, i.e. console input, is present, fixture can be adjusted for these three parameters on the U/I at the back of the unit.
Additional profile options			
Plus 7		Seven additional color control channels are available in RGB, HSI, HSIC, and Studio profile settings. For example HSI with ‘Plus 7’ enabled becomes a 14-channel profile:	
		1 – Hue (coarse) 2 – Hue (fine) 3 – Saturation 4 – Intensity 5 – Strobe 6 – n/a 7 – Plus 7 Control on/off 8 – Red 9 – Orange (white if Lustr+) 10 – Amber 11 – Green 12 – Cyan 13 – Blue 14 – Indigo	<p>The desired color and intensity is achieved by using the HSI or RGB channels.</p> <p>Placing channel seven at a value over 51% gives the fixture a 14-channel profile.</p> <p>Channels 8-14 represent the native colors of the fixture and allow the operator to adjust individual color channels to fine tune the color output.</p>
Strobe		Variable strobe control: 0% is no strobe. The fixture output will strobe more rapidly as the strobe channel value approaches 100%.	

PHOTOMETRICS

D40 Vivid

Mode	Degree	Candela	Field Lumens	Beam Lumens	Lumens Per Watt
Boost Full	10.5°	57,265	2,252	845	23.6
Regulated Full	10.5°	47,449	1,866	700	22.7
Regulated 3200K	10.5°	32,749	1,288	483	24.1
Regulated 5600K	10.5°	33,876	1,332	500	22.2

Metric conversions: For meters, multiply feet by 0.3048  
For lux, multiply footcandles by 10.76

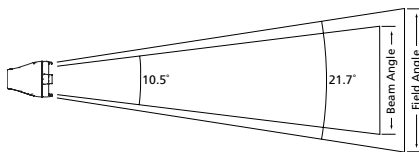

Throw Distance (d)	10ft	15ft	20ft	25ft	217.8ft
	3.0m	4.6m	6.1m	7.6m	66.4m
Field Diameter	3.8ft	5.7ft	7.7ft	11.5ft	-
	1.2m	1.8m	2.3m	3.5m	-
Illuminance (fc)	474	211	119	53	1
Illuminance (lux)	5,107	2,270	1,277	567	10.76

To determine center beam illumination in footcandles at any throw distance, divide candela by the throw distance squared

For field diameter at any distance, multiply distance by 0.383  
For beam diameter at any distance, multiply by 0.184

Cosine Candela Plot

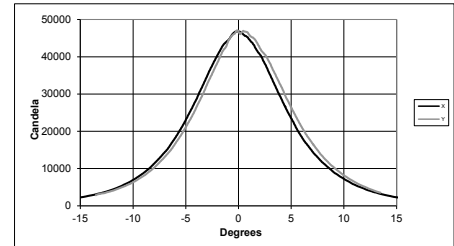

Iso-Illuminance Diagram (Flat Surface Distribution)

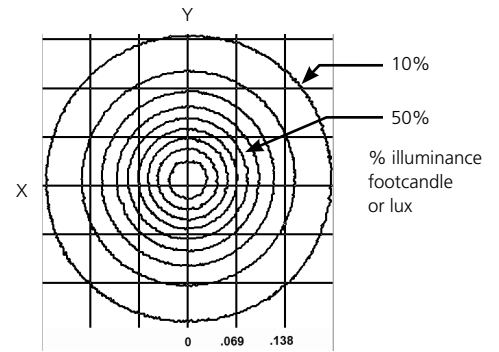

D40 Lustr+

Mode	Degree	Candela	Field Lumens	Beam Lumens	Lumens Per Watt
Boost Full	10.5°	71,324	2,593	1,042	25.2
Regulated Full	10.5°	64,071	2,329	936	25.0
Regulated 3200K	10.5°	46,299	1,683	676	29.4
Regulated 5600K	10.5°	40,173	1,460	587	26.8

Metric conversions: For meters, multiply feet by 0.3048  
For lux, multiply footcandles by 10.76

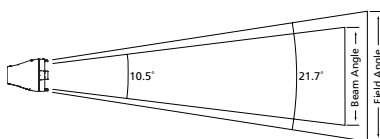

Throw Distance (d)	10ft	15ft	20ft	30ft	253.1ft
	3.0m	4.6m	6.1m	9.1m	77.2m
Field Diameter	3.8ft	5.7ft	7.7ft	11.5ft	-
	1.2m	1.8m	2.3m	3.5m	-
Illuminance (fc)	641	285	160	71	1
Illuminance (lux)	6,897	3,065	1,724	766	10.76

To determine center beam illumination in footcandles at any throw distance, divide candela by the throw distance squared

For field diameter at any distance, multiply distance by 0.383  
For beam diameter at any distance, multiply by 0.184

Cosine Candela Plot

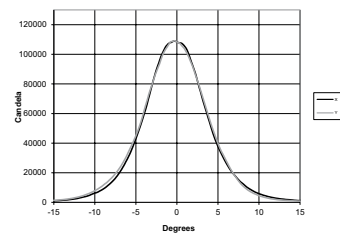

Iso-Illuminance Diagram (Flat Surface Distribution)

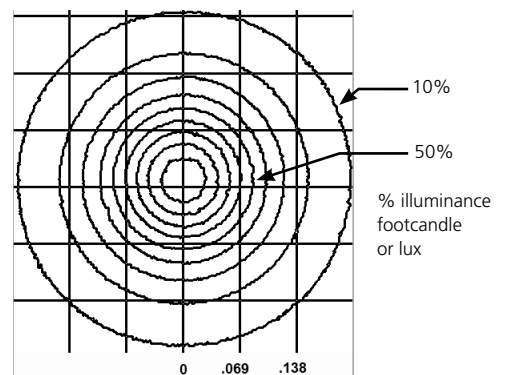

PHYSICAL

Selador D40 Weights and Dimensions

WEIGHT*		SHIPPING WEIGHT	
lbs	kgs	lbs	kgs
14	6.4	17	7.8

\* Does not include mounting hardware

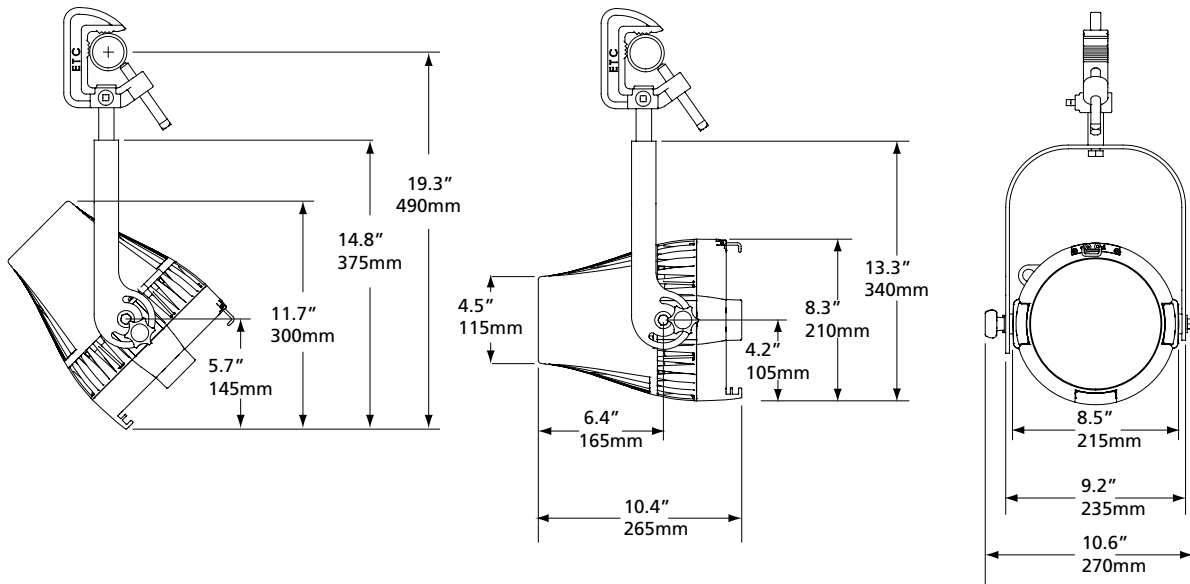

**Corporate Headquarters** • 3031 Pleasant View Rd, PO Box 620979, Middleton WI 53562 0979 USA • Tel +1 608 831 4116 • Fax +1 608 836 1736  
**London, UK** • Unit 26-28, Victoria Industrial Estate, Victoria Road, London W3 6UU, UK • Tel +44 (0)20 8896 1000 • Fax +44 (0)20 8896 2000  
**Rome, IT** • Via Pieve Torina, 48, 00156 Rome, Italy • Tel +39 (06) 32 111 683 • Fax +44 (0)20 8752 8486  
**Holzkirchen, DE** • Ohmstrasse 3, 83607 Holzkirchen, Germany • Tel +49 (80 24) 47 00-0 • Fax +49 (80 24) 47 00-3 00  
**Hong Kong** • Room 1801, 18/F, Tower 1 Phase 1, Enterprise Square, 9 Sheung Yuet Road, Kowloon Bay, Kowloon, Hong Kong • Tel +852 2799 1220 • Fax +852 2799 9325  
**Web** • www.etconnect.com • Copyright©2016 ETC. All Rights Reserved. All product information and specifications subject to change. 7410L1001 Rev. Q USA 03/2016

This product is protected by one or more of the following U.S. Patents: 6,016,038, 6,150,774, 6,788,011, 6,806,659, 6,683,423 and 7,023,543