

PHILIPS

dynalite 

DRC1220GL

12 x 20A Relay Controller
Installation Manual

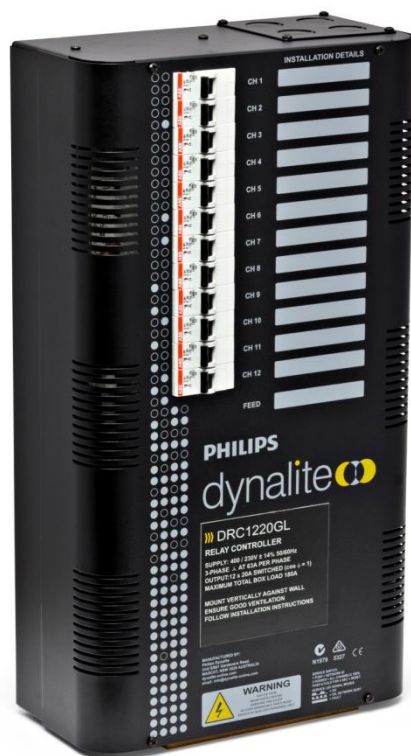

contents

Warning.....	2	Hardware Controls.....	7
Features.....	2	Troubleshooting.....	8
Important Safeguards.....	2	Specification.....	8
Internal View.....	3		
Mounting.....	4		
Supply & Load Cable Connections.....	5		
Connecting Serial Control Cables.....	6		

WMGD Pty Limited trading as Dynalite ABN 33 097 246 92

Unit 6, 691 Gardeners Road Mascot NSW 2020 Australia

t +61 8338 9899

f +61 2 8338 9333

dynalite.info@philips.com

philips.com/dynalite



Warning

- TO REDUCE THE RISK OF FIRE OR ELECTRIC SHOCK, DO NOT EXPOSE THIS DEVICE TO RAIN OR MOISTURE.
- DO NOT ENERGISE UNLESS THE FRONT COVER IS IN PLACE.
- THIS DEVICE MUST BE EARTHED.
- INSTALLATION, PROGRAMMING AND MAINTENANCE MUST BE CARRIED OUT BY QUALIFIED PERSONNEL

features

- **Three Phase Supply**
3 phase star at 63A per phase.
- **12 Switched Outputs**
Each 20A output is switched via a 50A relay.
- **MCB Protection**
Each output is protected by a 20A single pole magnetic circuit breaker.
- **Convection Cooled**
This device is naturally aspirated, requiring no mechanical cooling system, when installed in accordance with these instructions.
- **Many Control Options**
Control of this device can be from a combination of available methods, eg. serial control ports, relay contacts, push button wall stations, infra red receivers and timeclocks. Easy high level interface to other popular AV control systems and Building Management Systems (BMS) is also available. Available options include dual serial control ports, for applications such as network backup and DMX512 compatibility.
- **Simple Installation**
Wall mount enclosure with mounting lugs facilitate installation. Cable knockouts are provided at the top and right hand side of the enclosure for supply and load cables, with low voltage (LV) control at the bottom.

important safeguards

.....
Warning – This is a class A product. In a domestic environment this product may cause radio interference, in which case the user may be required to take adequate measures.

Read Instructions – We recommend that you read this Instruction Manual prior to commencement of installation.

Troubleshooting – If problems are encountered, read the troubleshooting section on page 8.

Special Programming – Once powered and terminated correctly this device will only operate in basic mode. A new Dynalite panel will turn on all lighting channels from button 1 and turn off from button 4 if network terminations are correct. Only once the full network is test correct can commissioning begin. Advanced functions can be commissioned via Envision software. If commissioning is required, contact your local distributor for details.

Check Connections – Treat this device as a switchboard that has been shipped. Tighten all load carrying screw connections, as vibrations from transport can cause MCB and terminal block screws to become loose.

Power Sources – This device should only be operated from the type of supply specified on the front panel. This device *must* be earthed.

Output Circuits – The load on a circuit should not exceed the specified capacity of 20A. Loads should be calculated to ensure that the overall maximum capacity of 189A is not exceeded.

Megger Testing – Do not megger test any circuitry connected to the dimming system, as damage to the electronics may result.

Mounting Location – This device must be mounted right way up, on a vertical surface (refer to page 4 for mounting instructions). The specified minimum clearance of 100mm for all sides should be adhered to. Install in a dry, well-ventilated location. Controllers may emit some mechanical noise. Take this into account when deciding the mounting location.

Data Cable – The recommended cable for connections to the serial port is screened, stranded RS485 data cable with three twisted pairs. Part numbers for various manufacturers are listed on page 6. This cable should be segregated from mains cables by a minimum distance of 300mm. Do not cut or terminate live data cables.

Load Types – This device is a switching controller. For applications that require dimming, and lamp protection features such as soft start, surge limiting and voltage regulation, a controller such as the Dynalite DLE1220GL-S (12 x 20A regulated outputs) should be considered.

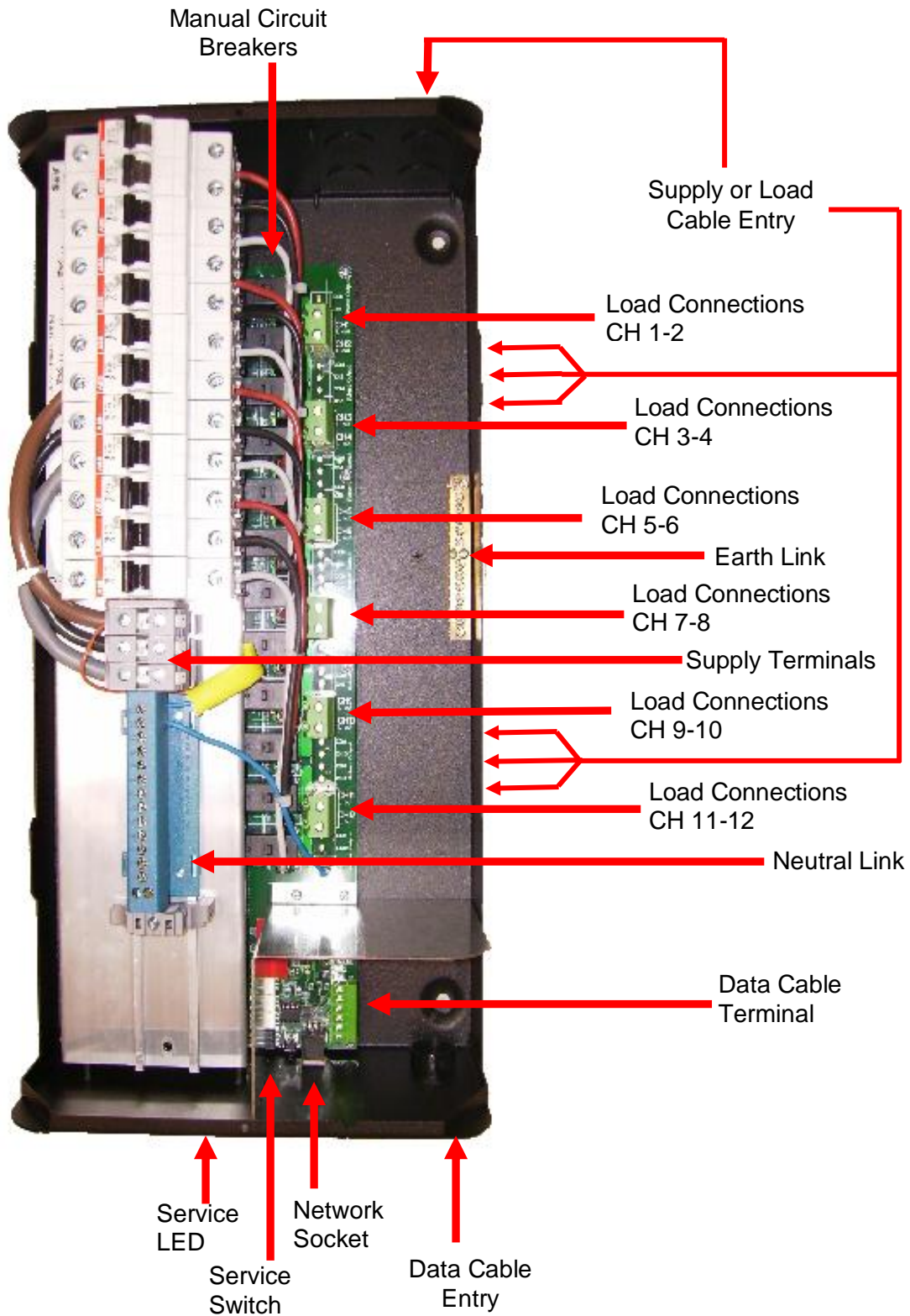

For spare parts, please call your nearest Dynalite Customer Service Centre, and specify **DRC1220GL**

mounting

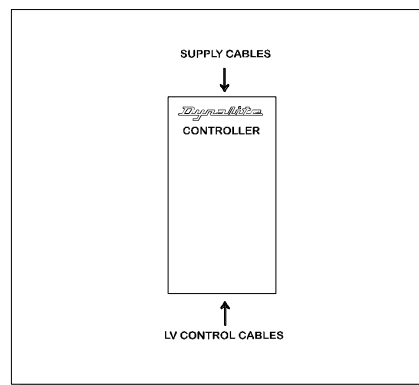
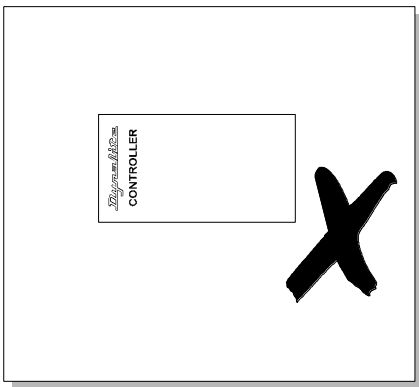
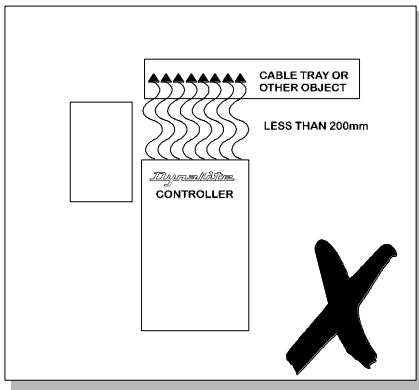
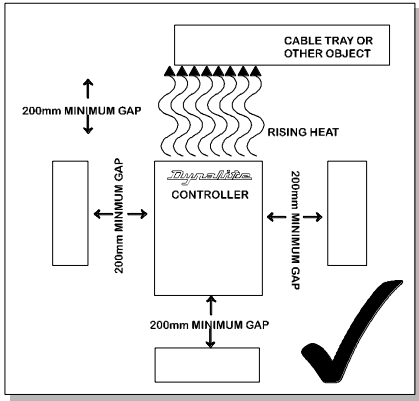

Select a Suitable Location

This device is designed for indoor use only. If installing in an external location, the DRC1220GL must be housed in a suitable well-ventilated enclosure. Choose a dry location, that will be accessible after the installation is complete. An air gap of 100mm on each side and at the top and bottom of the device should be adhered to. This air gap is required to ensure the serviceability of the DRC1220GL without its complete removal from the mounting surface. This device may emit some mechanical noise. Take this into account when deciding the mounting location.

Fixing the Device

The DRC1220GL has integral mounting brackets attached to the inside of the enclosure. The brackets are designed to accommodate 4 fixing screws up to 8mm diameter. The DRC1220GL can be fixed to the wall without opening the cabinet or removing covers. Make sure no dust or other debris enters the device during installation. Do not leave the front cover off for any length of time. Excessive dust and dirt can degrade the cooling of the internal components.

Allow for Cable Entry

Supply and load cables enter the enclosure at the side. If these cables are fed from below the mounting position, they should be routed around the enclosure to enter at the side, or alternative knockouts are provided on the right side of the lid line. An alternative method is to stand the enclosure off from the mounting surface by mounting it on a cable tray or a Unistrut style product. The cables can then be routed between the enclosure and the mounting surface, and enter the enclosure via the cutout provided on the mounting face. The control cables enter at the bottom of the enclosure. Control cables should never be run in the mains voltage sections of the enclosure.

supply & load cable connections

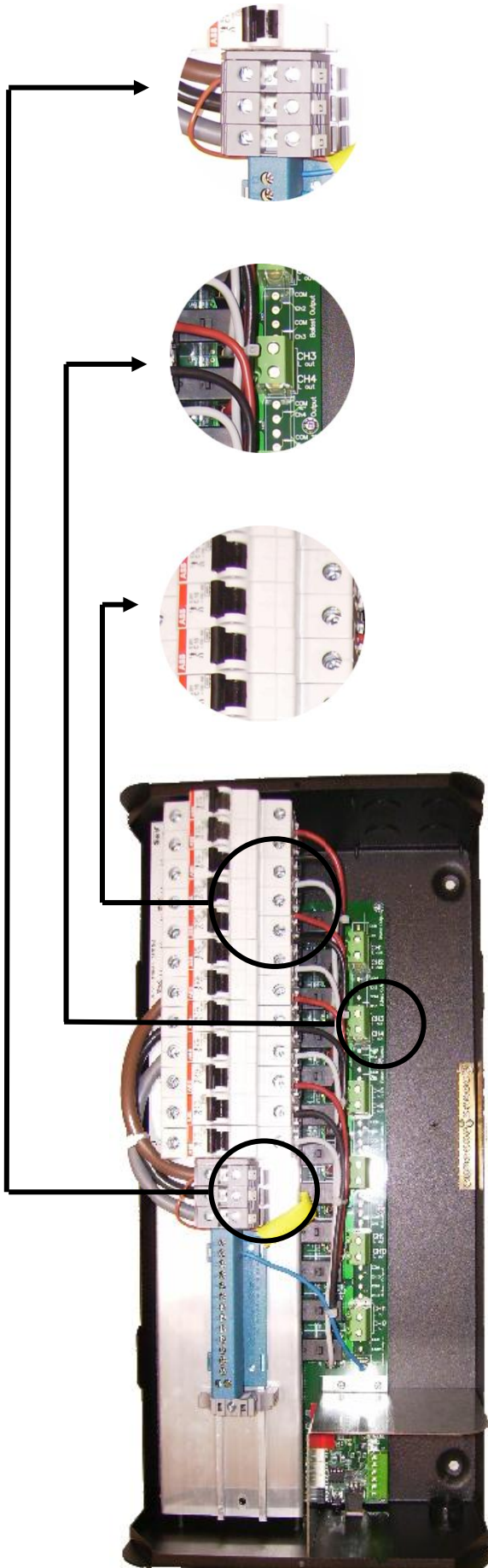

Supply Cables

The supply input terminals are located toward the middle of the enclosure and consists of Earth, Neutral, and 3 Phases, which will accept up to 35mm² cables. The supply cables should have a capacity of 63A per phase, to allow the device to be loaded to its maximum capacity.

Load Cables

Load cables can be terminated on the 2-way Load terminal blocks (two for each channel), a Neutral link and an Earth link located at the centre of the enclosure. These connectors will accept up to 10mm² cables. *It is important that an individual output circuit is not overloaded.* Calculate the intended load, and ensure that it is below the maximum capacity of an individual channel, which is 20A. To ensure compliance with interference standards, the load neutral cables must be individually connected to the neutral link terminals inside the cabinet. *Never use a common neutral at a remote location.*

Emergency Lighting Connections

Connect Emergency Lighting circuit active to the load side on the circuit breaker for the relevant channel, as indicated by the labels next to the circuit breakers. Do not remove any cables that may already be terminated at this location.

Energising the Device

If it is necessary to energise load circuits before any control cables are connected, it is acceptable to replace the cover and energise the device immediately, as the default factory programming is to have all channels set to 100% output. If there is no output on any or all channels, see the troubleshooting section (page 8). This device should be de-energised before terminating the control and data cables.

connecting serial control cables

Connect Data Cable in a 'Daisy Chain'

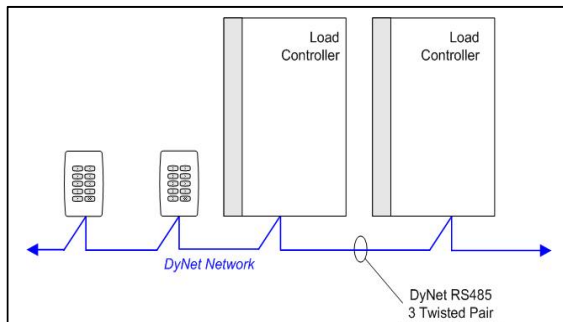

RJ12 Socket Connections

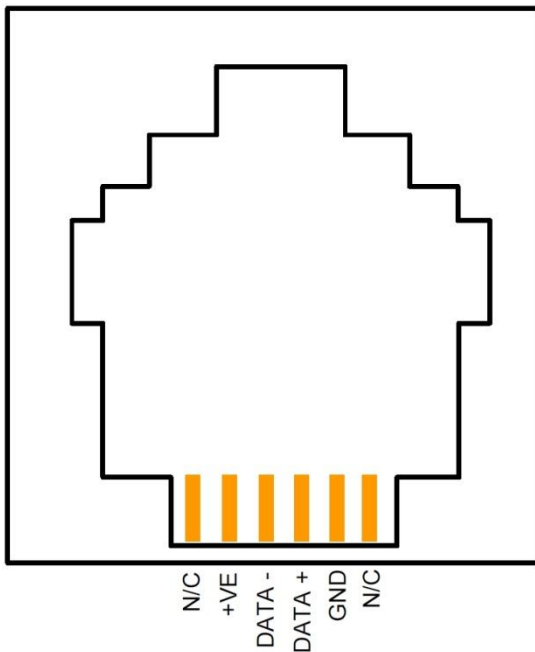

Serial Cable Permanent Connections

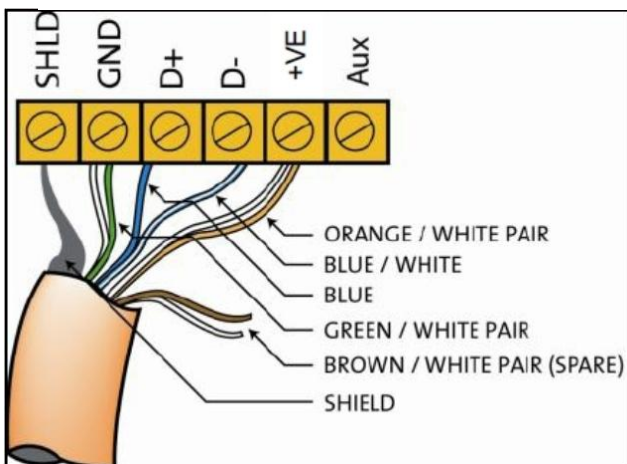

Determine your Requirements

Serial Ports are used to interconnect other dimmers, smart control panels, sensors and AV controllers. Serial port devices can be identified by 4 terminals, labelled: GND, DATA+ DATA-, +VE.

Serial Cable Connections

There is one RS485 port for DyNet signals, in the form of a RJ12 socket, on the front panel, which is used for the temporary connection of a PC or a DPP601 Portable Programmer. There are data terminals on the control card, for permanent connections. The recommended cable for connections to the serial port is screened, stranded RS485 data cable with three twisted pairs. Recommended cable types include:

Belden:	9503
Dynalite:	DYNET-STP-CABLE
Garland:	MCP3S
Hartland:	HCK603
M&M Cable:	B2003CS
M&M Cable:	B9503CS
Multicables:	AWM E120236 2092 20
RS Components:	368-687

One pair is paralleled for GND, one pair paralleled for +VE, and one pair used for DATA+ and DATA-.

Recommended Cable Colour Coding

Green/White pair	Paralleled for GND
Orange/White pair	Paralleled for +VE
Blue/White pair	Blue for DATA + White for DATA -
Brown/White pair	Spare or for Join

The colour-coding scheme used is not critical, as long as the same scheme is used throughout the installation.

Serial Cable Connecting Method

The recommended connecting method is to 'daisy chain' devices (starting at the first device, then looping in then out of devices, with a single cable terminating at the last device. There should not be any spurs or stubs, and only the first and last device should terminate one cable. All other devices should terminate two cables). Devices may be wired in any order. The data cable should be segregated from any mains cables. *A data cable that is connected to an energised dimmer is live. Do not cut or terminate live data cables.* If the data cable has to cross over any mains cables, it should do so at a 90° angle.

hardware controls

.....
AUX Input – This is a dry contact interface that is active low. The dry contact is connected between the AUX and GND terminals on the DyNet connector strip. The function of the AUX input is programmable. Ensure that the cable length between the dry contact and terminal strip is no longer than 2 metres.

Service LED - The Service LED has 3 signalling modes, which are useful for troubleshooting:
Blinking slowly (1Hz) = Normal Operation
Blinking quickly (4Hz) = Network Activity Detected
On = Fault

Service Switch – The Service Switch has three functions:
1 push = Transmit Network ID
3 pushes = All Channels 100%
Push & hold for 4 sec = Reboot

Top Set - This control is not used on relay controllers

Accessory Module Socket – Accepts plug in module for an optional feature such as a DMX512 port. Consult your Dynalite dealer for details on available accessory modules.

troubleshooting

Check the following list. If you are still unable to rectify the situation, contact your nearest Dynalite dealer. A complete list of distributors worldwide can be found on the Internet at: www.philips.com/dynalite
Please ensure that you have completed the following prior to calling our technical support department.

- Check all symptoms in the Troubleshooting list
- Check for any deviations between the installation and the installation instructions
- Make a list of the model numbers of all devices used in the system

SYMPTOM	PROBABLE CAUSE	ACTION
Device does not operate at all. No Service LED activity. Power supply indicator LED on PCB not lit.	Incorrect connection of Mains supply, or no power available.	Check power supply to device. Check Line and Neutral input connections.
Power supply indicator LED lit, but no Service LED activity.	Supply voltage too low, short circuit on network or short circuit on AUX inputs. Control PCB faulty.	Check supply voltage is at least 75% of rated voltage. Check 5V & 12V terminal voltages, 5V supply must be present. Disconnect network bus and restore power. Replace control PCB.
Device appears to be operating but all channels at full output.	Incorrect wiring on serial port. PANIC function activated.	Check serial port wiring, verify control panel operation. Check operation of panic switch if fitted.
Device will not respond to control panel push buttons.	Control panel incorrectly wired or "Buttons". Incorrect configuration.	Check operation of LEDs on control panel. Push button on panel and study response of service LED.
Device operates properly but circuit breakers keep tripping.	Instant tripping: Short circuit on load. Delayed tripping: Device overloaded.	Check load wiring for short circuits. Verify device loading with current tester (don't forget to de-rate for low power-factor loads and transformer losses). Check that breaker terminals are tight.
Fluorescent lights won't dim.	Wrong type of ballast or ballast incorrectly wired	Check ballast type. Check actual wiring against ballast manufacturer's diagram.

specification

Supply:	230V ±14% 50/60Hz 3-Phase Y at 63A per phase
Outputs:	12 x Switched outputs at 20A per channel
Protection:	12 x 20A 6kA single pole thermal magnetic circuit breakers
Switching Device:	Relay – 50A 230V AC inductive (5000W lighting load rated)
Control Inputs:	1 x RS485 DyNet serial port 1 x Programmable dry contact AUX input
User Controls:	Service switch Diagnostic LED
DyNet DC Supply +VE:	200mA (Supply for approx 6 panel)
Preset Scenes:	170
Supply Terminals:	Line1, Line2, Line3 1 x 35mm ² max conductor size
Output Terminals:	Line for each channel 1 x 10mm ² max conductor size Neutral link bar provided Earth link bar provided
Cable Entry:	Mains – 4 x 25mm dia. knockouts mounted on a 85mm x 85mm removable gland plate Loads – 6 x 25mm dia. knockouts located on the right hand side of the unit Data – 1 x 25mm dia. knockout
Diagnostic Functions:	Device online/offline status Circuit breaker trip reporting (optional) Circuit run time tracking (optional)
Compliance:	CE, C-Tick
Operating Environment:	Ambient Temperature 40°C max. RH 90% max non condensing
Construction:	Alloy/Steel wall mount case with epoxy finish
Dimensions:	H 457mm x W 211mm x D 126mm
Dimensions –RCBO Version:	H 585mm x W 211mm x D 126mm
Weight:	10.25 kg

DRC1220GL Installation Manual Rev I.doc Specifications and design subject to change without notice.
Dynalite Manufactured by WMGD Pty Ltd (ABN 33 097 246 921). All rights reserved. Dynalite, Dimtek, DyNet and DLight and associated logos are the registered trademarks of Dynalite Intelligent Light Pty Ltd. Not to be reproduced without permission.
Unit 6, 691 Gardeners Road Mascot NSW 2020 Australia Tel: +61 2 8338 9899 Fax: +61 2 8338 9333
E-mail: dynalite.info@philips.com Web: Philips.com/dynalite