DLE1220GL-S

12 x 20A Leading Edge Dimmer Installation Manual



contents

Features.....	2	Dimmable Lamps Chart.....	7
Important Safeguards.....	2	Troubleshooting.....	8
Internal View.....	3	Specifications.....	8
Mounting.....	4		
Supply & Load Cable Connections.....	5		
Connecting Serial Control Cables.....	6		
Hardware Controls.....	7		



Warning

- TO REDUCE THE RISK OF FIRE OR ELECTRIC SHOCK, DO NOT EXPOSE THIS DEVICE TO RAIN OR MOISTURE.
- DO NOT ENERGISE UNLESS THE FRONT COVER IS IN PLACE.
- THIS DEVICE MUST BE EARTHED.
- INSTALLATION, PROGRAMMING AND MAINTENANCE MUST BE CARRIED OUT BY QUALIFIED PERSONNEL.

important safeguards

.....
Warning – This is a class A product. In a domestic environment this product may cause radio interference, in which case the user may be required to take adequate measures.

Read Instructions – We recommend that you read this Instruction Manual prior to commencement of installation. Retain instructions and give the end user.

Troubleshooting - If problems are encountered, check the troubleshooting section on page 8.

Special Programming – Once powered and terminated correctly this device will only operate in basic mode. A new Dynalite panel will turn on all lighting channels from button 1 and turn off from button 4 if network terminations are correct. Only once the full network is test correct can commissioning begin. Advanced functions can be commissioned via Envision software. If commissioning is required, contact your local distributor for details.

Check Connections – Treat this device as a switchboard that has been shipped. Tighten all load-carrying screw connections, as vibrations from transport can cause MCB and terminal block screws to become loose.

Power Sources – This device should only be operated from the type of supply specified on the front panel. This device *must* be earthed.

Output Circuits – The load on a circuit should not exceed the specified capacity of 20A. Loads should be calculated to ensure that the overall maximum capacity of 189A is not exceeded. Some types of load will need to be de-rated. Check the Dimmable Lamps Chart on page 7 for more information.

Mounting Location – This device must be mounted right way up, on a vertical surface (refer to page 4 for mounting instructions). The specified minimum clearance of 200mm for all sides must be adhered to. Install in a dry, well-ventilated location. Controllers may emit some mechanical noise. Take this into account when deciding the mounting location.

Data Cable – The recommended cable for connections to the serial port is screened, stranded RS485 data cable with three twisted pairs. Part numbers for various manufacturers are listed on page 6. This cable should be segregated from mains cables by a minimum distance of 300mm. If anticipated cable runs are over 600 metres for serial cables or 12 metres for analogue cables, consult your dealer for advice. Do not cut or terminate live data cables.

Load Type – The factory default settings are for all channels to be dimmable. Do not terminate any non-dimmable loads until the relevant channel has been programmed as switching only. See the Dimmable Lamps Chart on page 7. If it is necessary to energise a switched load before programming has occurred, temporarily connect the load to the emergency lighting terminal, instead of the dimmed output terminal, see page 5. Some types of load will need to be de-rated, check for details in the Dimmable Lamps Chart on page 7.

features

-
- **Three Phase Supply**
3 phase star at 63A per phase.
 - **12 Dimmed Outputs**
Each 20A output is independently regulated, protecting loads from voltage surges and spikes.
 - **Circuit Breaker Protection**
Each output is protected by a 20A single pole magnetic circuit breaker.
 - **Convection Cooled**
This device is naturally aspirated, requiring no mechanical cooling system, when installed in accordance with these instructions.
 - **Many Control Options**
Control of this device can be via a combination of methods, eg. serial control port, relay contacts, push button wall stations, infra red receivers and timeclocks. Easy high level interface to other popular AV control systems and Building Management Systems (BMS) is also available. This device is DMX512 compatible, and has dual serial control ports, for applications such as network backup.
 - **Simple Installation**
Wall mount enclosure with mounting lugs facilitates installation. Cable knockouts are provided, at the top of the enclosure for supply and load cables, with low voltage (LV) control at the bottom.

internal view

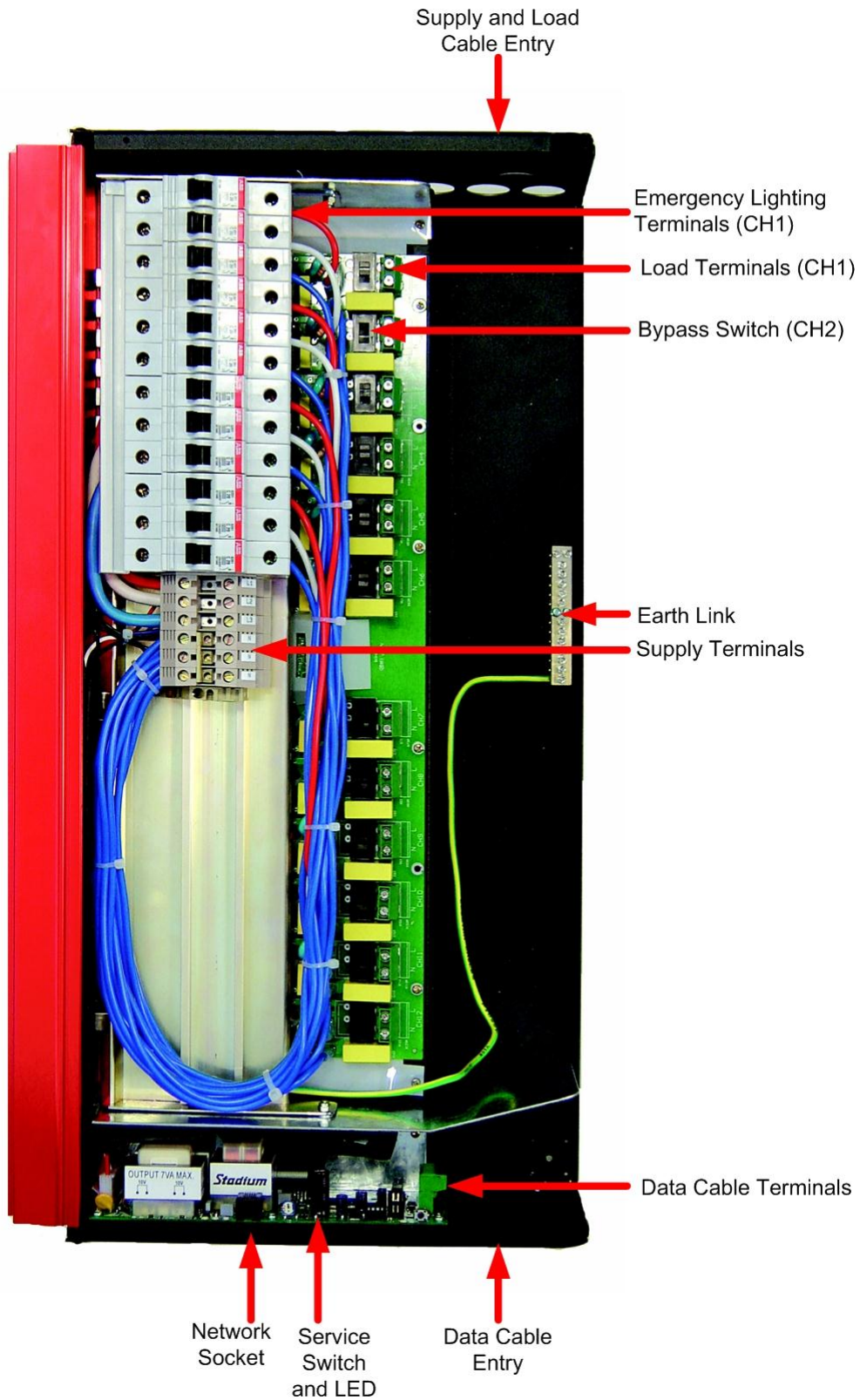

For spare parts, please call your nearest Dynalite Customer Service Centre and specify:

DLE1220GL-S

mounting

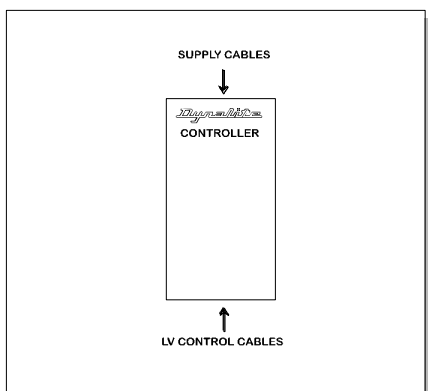
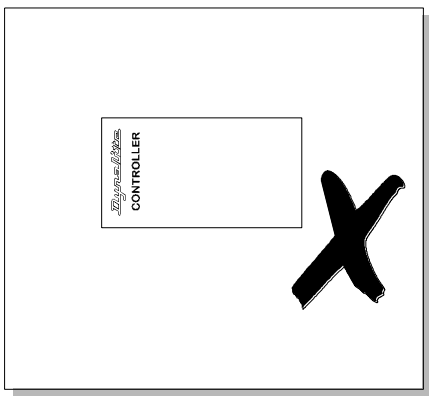
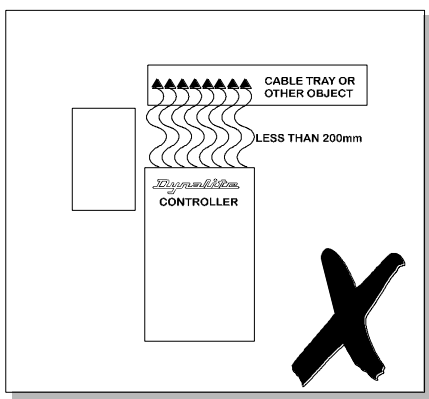
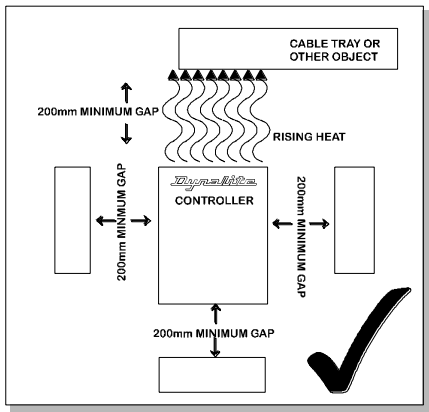

Select a Suitable Location

This device is designed for indoor use only. If installing in an external location, the DLE1220GL-S must be housed in a suitable well-ventilated enclosure. Choose a dry location, that will be accessible after the installation is complete. To ensure the cooling system functions correctly, the DLE1220GL-S should only be mounted *vertically, the right way up*. The DLE1220GL-S will generate heat when operating, approximately 2 Watts per Amp of load, and requires an air gap of 200mm on each side and at the top and bottom of the device. This air gap is also required to ensure serviceability of the DLE1220GL-S without complete removal from the mounting surface. This device may emit some mechanical noise. Take this into account when deciding the mounting location.

Fixing the Device

The DLE1220GL-S has integral mounting brackets attached to the enclosure. The brackets are designed to accommodate 4 fixing screws up to 8mm diameter. The DLE1220GL-S can be fixed to the wall without opening the cabinet or removing covers. Make sure no dust or other debris enters the device during installation. Do not leave the front cover off for any length of time. Excessive dust and dirt can degrade the cooling of internal components.

Allow For Cable Entry

Supply and load cables enter the enclosure at the top. If these cables are fed from below the mounting position, they should be routed around the enclosure to enter at the top. An alternative method is to stand the enclosure off from the mounting surface by mounting it on a cable tray or a Unistrut style product. The cables can then be routed between the enclosure and the mounting surface, and enter the enclosure via the cutout provided on the mounting face. The control cables enter at the bottom of the enclosure. Control cables should never be run in the mains voltage sections of the enclosure.

supply & load cable connections

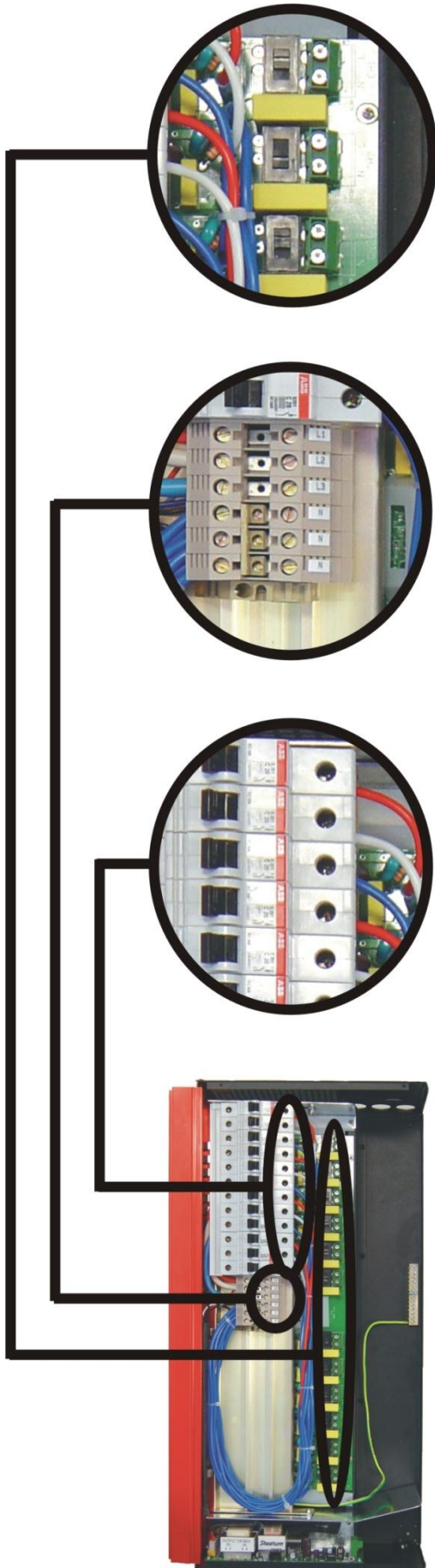

Supply Cables

The supply terminals are located toward the top of the enclosure and consist of Earth, Neutral, and Phase, all of which will accept up to 25mm² cables. The supply cables should have a capacity of 63A per phase, to allow the device to be loaded to its maximum capacity.

Load Cables

Load cables can be terminated on a Load & Neutral terminal strip, one pair for each channel, and an Earth link located at the centre of the enclosure. These connectors will accept up to 6mm² cables. Calculate the intended load, and ensure that it is below the maximum capacity of an individual channel, which is 20A. Do not use a common neutral at a remote location.

Emergency Lighting Connections

Emergency lighting of the non-maintained type may be fed from the load side on the circuit breaker for the relevant channel, as indicated by the labels next to the circuit breakers. Do not remove any cables that may already be terminated at this location.

Energising the Device

If it is necessary to energise load circuits before any control cables are connected, it is acceptable to replace the cover and energise the device immediately, as the default factory programming is to have all channels set to 100% output. If there is no output on any or all channels, see the troubleshooting section (page 8).

This device should be de-energised before terminating the control and data cables.

connecting serial control cables

Connecting Data Cable

Connect Data Cable in a 'Daisy Chain'

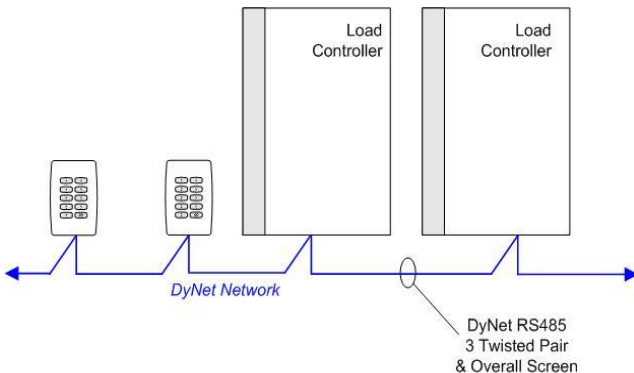

RJ12 Socket Connections

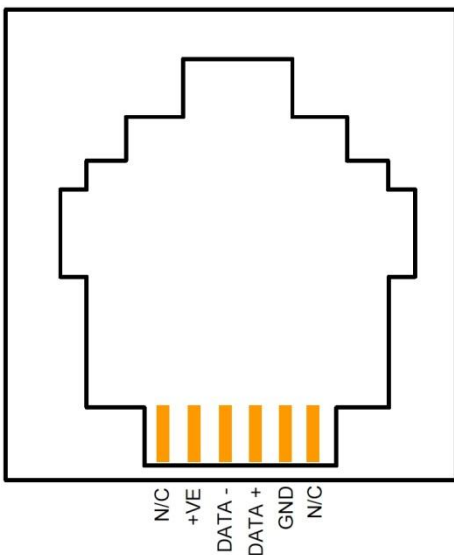

Serial Cable Permanent Connections

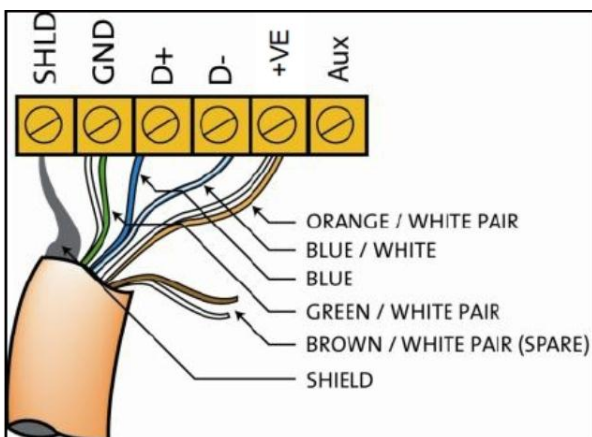

Determine Your Requirements

Serial ports are used to interconnect other dimmers, smart control panels, sensors and AV controllers. Serial port devices can be identified by 4 terminals, labelled: GND, DATA+, DATA-, +VE.

Serial Cable Connections

There is one RS485 port for DyNet[®] signals, in the form of a RJ12 socket, on the front panel, which is used for the temporary connection of a PC or a Portable Programmer (DPP601). There are data terminals on the control card, for permanent connections. The recommended cable for connections to the serial port is screened, stranded RS485 data cable with three twisted pairs. Recommended cable types include:

- Belden: 9503
 - Garland: MCP3S
 - Hartland: HCK603
 - M&M Cable: B2003CS
 - M&M Cable: B9503CS
 - Multicables: AWM E120236 2092 20
 - RS Components: 368-687
 - Dynalite: DYNET-STP-CABLE
- One pair is paralleled for GND, one pair paralleled for +VE, and one pair used for DATA+ and DATA -.

Recommended Cable Colour-Coding

- Green/White pair Paralleled for GND
- Orange/White pair Paralleled for +VE
- Blue/White pair Blue for DATA+
- White for DATA-
- Brown/White pair Spare or Shield

If using unshielded cable terminate the brown pair to the Shield terminal. The colour-coding scheme used is not critical, as long as the same scheme is used throughout the installation.

Serial Cable Connecting Method

The recommended connecting method is to 'daisy chain' devices (ie. starting at the first device, then looping in then out of devices, with a single cable terminating at the last device. There should not be any spurs or stubs, and only the first and last device should terminate 1 cable, all other devices should terminate 2 cables). Devices may be wired in any order. The Data Cable should be segregated from any Mains Cables by 30mm. *A data cable that is connected to an energised dimmer is live. Do not cut or terminate live data cables.* If the Data Cable has to cross over any Mains Cables, it should do so at a 90° angle.

Hold Down Programming Of Presets

AUX Input - This is a dry contact interface that is active low. The dry contact is connected between the AUX and GND terminals on the DyNet connector strip. The function of the AUX input is programmable. Ensure that the cable length between the dry contact and terminal strip is no longer than 2 meters.

Service LED - The Service LED has 3 signaling modes, which are useful for troubleshooting:
 Blinking slowly (1Hz) = Normal Operation
 Blinking fast (4Hz) = Network Activity Detected
 On = Fault

Service Switch - The Service Switch has three functions:
 1 push = Transmit Network ID
 3 pushes = All Channels 100%
 Push & hold for 4 sec = Reboot

Top Set - This adjusts the maximum output that all other control sources can select, ie: if the Top Set is fully clockwise, 100% selected by a control source will give 100% output. If it is fully anti-clockwise, 100% selected by a control source will give 50% output. This control is useful for extending lamp life and can be operated without any form of network control, effectively turning the device into a standalone power conditioner and lamp protector.

Accessory Module Socket - Accepts plug in modules for optional features such as DMX512 ports. Consult your distributor for details on the available accessory modules.

dimnable lamps chart

INCANDESCENT LAMPS	Incandescent lamps are easily dimmed using all Dyalite controllers. The soft start and voltage limit features will extend lamp life. Lamp life can be further extended using the voltage limit adjustment.
TUNGSTEN HALOGEN LAMPS	Tungsten halogen and other transformer loads are easily dimmed using all Dyalite controllers. The soft start, cleanup and surge limiting features will protect lamps against premature failure. Lamp life can be extended using the voltage limit adjustment.
FLUORESCENT LAMPS (38mm)	38mm Rapid start lamps can be successfully dimmed to 40% using an inexpensive filament driver transformer. For better performance, an electronic HF dimming transformer is recommended. The power factor capacitors need to be wired to the supply side of the dimmer. Some Dyalite controllers include a supplementary relay contact for control of power factor capacitor. If electronic ballasts are not used, cabling and controllers should be de-rated by approx. 60% to allow for reactive current. Contact your Dyalite dealer for more information.
FLUORESCENT LAMPS (26mm)	26mm Slimline tubes can be dimmed to as low as 5% using a dimmable full electronic ballast or electronic dimming transformer. No de-rating is necessary with electronic ballasts. Contact your Dyalite dealer for more information.
COMPACT FLUORESCENTS	Only some types of 4 pin PL lamps can be successfully dimmed using dimmable electronic ballasts. Best results are achieved with 4 wire HF ballasts.
NEON	Only argon filled neon lamps can be reliably dimmed. The power factor capacitors need to be wired to the supply side of the dimmer. Cabling and controllers should be de-rated by approximately 60% to allow for reactive current. Any open circuit monitoring on the neon transformer must be suitable for dimming.
HID SOURCES	Mercury vapour and sodium lamps can be dimmed to approximately 40%. For successful dimming to low levels, the fade time should be set to very slow speeds (> 30sec) to avoid "cut out" problems. The power factor capacitors need to be wired to the supply side of the dimmer. Some Dyalite controllers include a supplementary relay contact for control of power factor capacitors. Cabling and controllers should be de-rated by approximately 60% to allow for reactive current. Contact your Dyalite dealer for more information.
METAL HALIDE	Metal halide lamps give similar dimming performance to other HID sources, however, the colour of the light tends to change in an unpredictable way in most lamps when dimmed (often permanently). Most lamp manufacturers do not recommend dimming of metal halide lamps. Contact your Dyalite dealer for more information.

troubleshooting

Check the following list. If you are still unable to rectify the situation, contact your nearest Dynalite office. A complete list of distributors worldwide can be found on the Internet at: <http://dynamite-online.com/html/contacts.htm>. Please ensure that you have completed the following prior to calling our technical support department.

- Check all symptoms in the Troubleshooting list
- Check for any deviations between the installation and the installation instructions
- Make a list of the model numbers of all devices used in the system

SYMPTOM	PROBABLE CAUSE	ACTION
Dimmer does not operate at all. No Service LED activity. Power supply indicator LED on PCB not lit.	Incorrect connection of Mains supply, or no power available.	Check power supply to dimmer. Check Line and Neutral input connections.
Power supply indicator LED lit, but no Service LED activity.	Supply voltage too low, short circuit on network or short circuit on analogue inputs. Control PCB faulty.	Check supply voltage is at least 75% of rated voltage. Check 5V & 12V terminal voltages, 5V supply must be present. Disconnect network bus and restore power. Replace control PCB.
Dimmer appears to be operating but some or all channels at full output.	Bypass switches turned on. PANIC function activated.	Check bypass switches. Deactivate panic function.
Dimmer will not respond to control panel push buttons.	Control panel incorrectly wired or incorrect configuration.	Check operation of LEDs on control panel. Push button on panel and study response of service LED.
Dimmer operates properly but circuit breakers keep tripping.	Instant tripping: - short circuit on load. Delayed tripping: - Dimmer overloaded.	Check load wiring for short circuits. Verify dimmer loading with current tester (don't forget to de-rate for low power-factor loads and transformer losses). Check that the breaker terminals are tight.
Fluorescent lights won't dim.	Wrong type of ballast or ballast incorrectly wired	Check ballast type. Check actual wiring against ballast manufacturer's diagram.

specification

Supply:	230V ±14% 50/60Hz 3-Phase Y at 63A per phase
Outputs:	12 x leading edge dimmed outputs at 20A per channel
Maximum Device Load:	189A
Regulating Device:	Dual SCRs – 800V, 55A nom., 550A surge
Overload Protection:	20A 6KA thermal magnetic breaker on each channel
Interference Suppression:	Iron powder toroidal chokes Rise time: 400µS at 110V supply, 200µS at 230V supply
Minimum Load:	20W per channel
Control IO:	1 x RS485 DyNet / DMX512 serial port 1 x programmable dry contact AUX input
User Controls:	Service Switch Diagnostic LED 3 x Phase LED's Bypass switch for each channel
Presets:	170
DyNet DC Supply:	200mA (supply for approx. 15 Smart Panels)
Cable Entries:	Mains - 5 x 25mm ² knockouts on a 105mm x 145mm removable gland plate Data - 1 x 25mm ² dia. knockout
Compliance:	CE, C-Tick
Operating Environment:	0°C to 40°C ambient temperature 0% to 95% RH non condensing
Construction:	Alloy/Steel wall mount case with epoxy finish
Dimensions:	Height 600mm x Width 335mm x Depth 187mm (excluding wall brackets)
Weight:	35 Kilograms

DLE1220GL-S Installation Manual Rev H.doc Specifications and design subject to change without notice.
 Dynalite Manufactured by WMGD Pty Ltd (ABN 33 097 246 921). All rights reserved. Dynalite, Dimtek, DyNet and DLight and associated logos are the registered trademarks of Dynalite Intelligent Light Pty Ltd. Not to be reproduced without permission.
 Unit 6, 691 Gardeners Road Mascot NSW 2020 Australia Tel: +61 2 8338 9899 Fax: +61 2 8338 9333
 E-mail: dynamite.info@philips.com Web: Philips.com/dynamite