

The Dyalite DDNG100BT provides cost effective integration between Philips Dyalite control systems and Ethernet networks. It is designed to provide remote control of sites and link multiple sites together, using the Internet or a corporate LAN as a backbone. The device supports the TCP/IP protocol, with static or DHCP assigned IP addressing. Routing Mode links multiple DDNG100BT's together in point to point or broadcast modes. An integral webserver allows Browser based control scenarios. The interface incorporates a Programmable Logic Controller that can process comprehensive conditional and sequential logic and arithmetic functions. The DDNG100BT is capable of routing DyNet to third-party systems, such as audio-visual and building automation systems, providing an integrated approach to total building control and energy management.

technical data 



**Supply**

230V  $\pm 14\%$  50/60Hz Single Phase at < 0.1A

**Serial Ports**

1 x RS485 DyNet serial port  
1 x 10/100BaseT Ethernet port

**Supported Ethernet Protocols**

TCP/IP (TCP & UDP)  
HTTP  
FTP  
Telnet  
Encryption: AES - 256 bit

**DyNet DC Supply**

12V @ 90mA

**Supply Terminals**

Phase, Neutral  
1 x 4mm<sup>2</sup> max conductor size  
DNG100BT - Earth link bar provided

**Serial Port Terminals**

DyNet RS485:  
Shield, GND, D-, D+, +12V  
All available on screw terminals  
1 x 2.5mm<sup>2</sup> max conductor size  
Also available on RJ12 socket

Ethernet:

Female RJ45 socket

**Diagnostic Functions**

Device Online/Offline status

**Compliance**

CE, C-Tick

**Operating Environment**

0° to 50°C ambient temperature  
0% to 95% RH non condensing

**Construction**

Polycarbonate DIN Rail enclosure  
(12 unit)

**Dimensions**

H 93mm x W 211mm x D 75mm

**Weight**

Packed weight 0.86kg

electrical diagram >>>

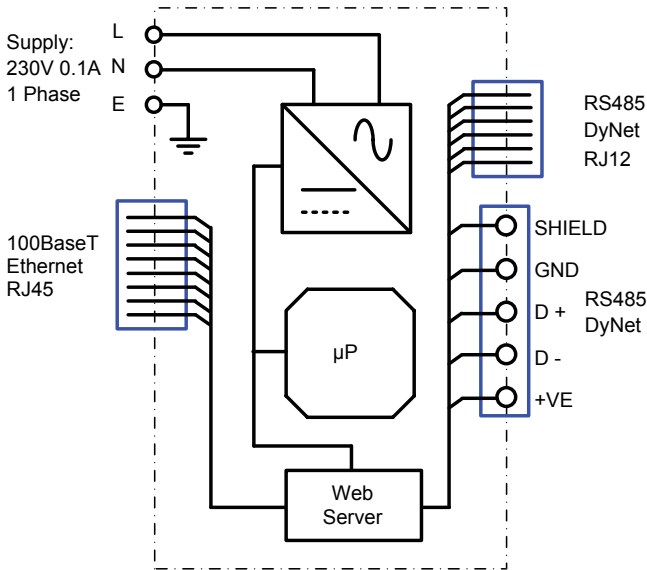

mounting dimensions >>>

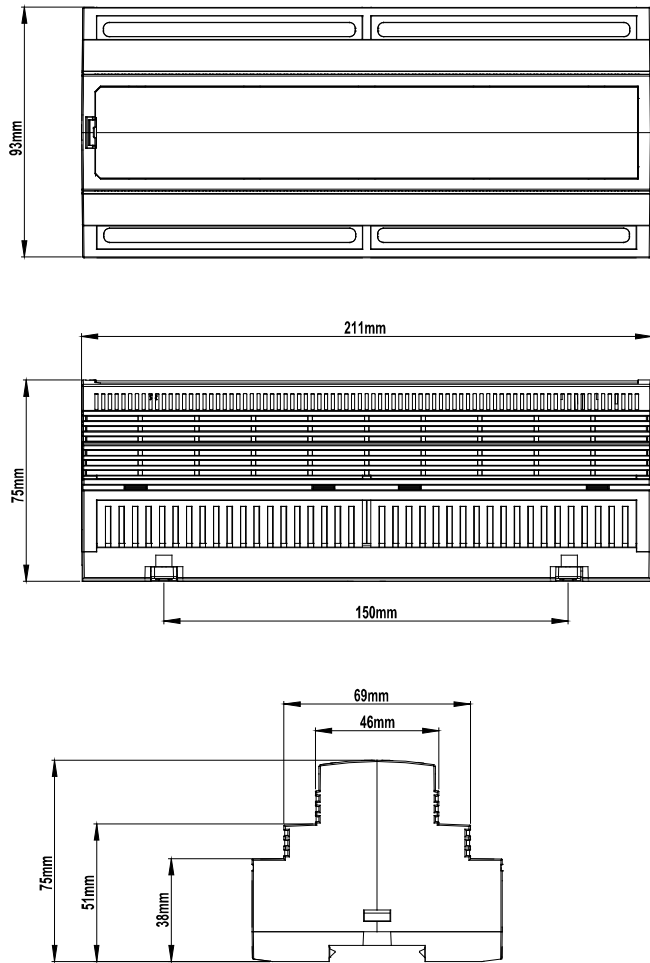

Supplied by:

**lightmoves**

**Melbourne**  
03 9701 2500

**Sydney**  
02 9737 8988

info@lightmoves.com.au www.lightmoves.com.au