

DLLEDC60035

6 x 350mA LED Controller

Installation manual



features

- **External DC Supply** - 18-32VDC, can be sized to suit the LED fixture load
- **6 x Current Mode Common Anode LED Outputs** - Rated 4 Watts per individual channel, 6 Watts combined total for consecutive pairs of channels (Ch 1&2, Ch 3&4, Ch 5&6), 18 Watts Box Total
- **RS485 Serial Port Supports DyNet and DMX512 protocols**
- **Many Control Options** - Control of this device can be via a combination of methods, eg. serial control port, relay contacts, push button wall stations, infrared receivers and time clocks
- **Simple Installation** - DIN Rail mount facilitates installation. All connection terminals are accessible without disassembly

WARNING
 ISOLATE FROM MAINS SUPPLY BEFORE REMOVING THIS COVER
 NO USER SERVICEABLE PARTS INSIDE
 SERVICE BY QUALIFIED PERSONNEL ONLY

To reduce the risk of fire or electric shock, do not expose this device to rain or moisture. Do not energise unless the front cover is in place. This device must be earthed. Installation, programming and maintenance must be carried out by qualified personnel.

Read Instructions – We recommend that you read this Instruction Manual prior to commencement of installation.

Special Programming – Once powered and terminated correctly this device will only operate in basic mode. A new Dynalite panel will turn on all lighting channels from button 1 and turn off from button 4 if network terminations are correct. Only once the full network is test correct can commissioning begin. Advanced functions can be commissioned via Envision software. If commissioning is required, contact your local distributor for details.

Check Connections – Tighten all load-carrying screw connections, as vibrations from transport can cause terminal block screws to become loose.

Power Sources – This device requires an appropriately sized external DC supply to operate, this DC supply should have better than 5% regulation, and <1V PP ripple at full load. This device *must* be earthed.

Output Circuits – This device is designed to control 350mA Current Mode Common Anode LED loads. Connecting this device to other load types may damage this controller and / or your loads.

Mounting Location – Install in a dry, well-ventilated location. Controllers may emit some mechanical noise. Take this into account when deciding the mounting location.

Data Cable – Use screened, stranded RS485 data cable with three twisted pairs. Segregate from mains cables by 300mm minimum. Connect devices in a 'daisy chain'. A data cable that is connected to an energised device is live. Do

electrical diagram

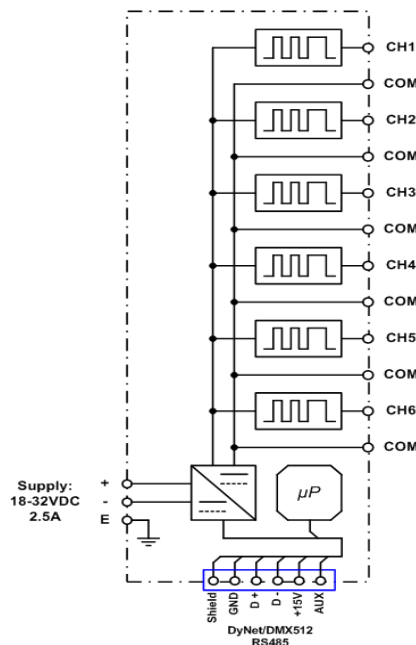

installation steps

1. Mount the device on a DIN rail inside an approved enclosure.
2. Calculate loads to ensure any channels will not be overloaded. The maximum loading of this device is whichever is the lesser for the following values:
 - 4 Watts per individual channel
 - 6 Watts combined total for consecutive pairs of channels (Ch 1&2, Ch 3&4, Ch 5&6)
 - 18 Watts Box Total
3. Check the type of drive your LED array requires against the output mode of this controller, which is:
 - 350mA Current Mode, Common Anode. Connect the LED arrays to the output terminals.
4. Determine the type of external DC supply required for your load:
 - Maximum Supply Voltage: $V_s \text{ max} = 8.5 + (n \times V_{\text{led}})$ or 32VDC, whichever is the lesser.
 - Minimum Supply Voltage: $V_s \text{ min} = 4 + (n \times V_{\text{led}})$ or 18VDC, whichever is the greater.

$V_s \text{ max}$ = Maximum supply voltage, $V_s \text{ min}$ = Minimum supply voltage, n = Number of diodes in series per channel, V_{led} = LED forward voltage. DC supply should be rated at 2.5A if the device is to be fully loaded, have better than 5% regulation, and < 1V PP ripple at full load. Contact your Dynalite distributor for advice in selecting a suitable DC supply.
5. Connect the DC supply to the Supply terminals. Be careful of the polarity when connecting the supply, + to+ and - to -. Use 2.5mm² cable size as a minimum, and keep the cable length between the DC supply and the DDLED60035 under 10 metres. This device must be earthed.
6. Connect data cables to the device as per diagrams below.

connecting data cable

Connect Data Cable in a 'Daisy Chain'

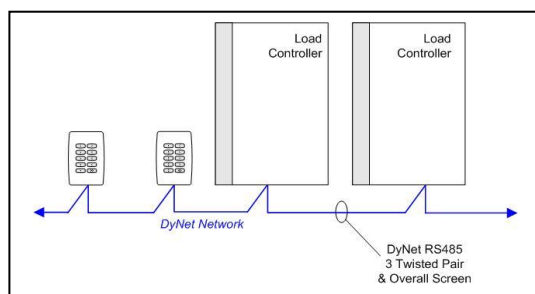

RJ12 Socket Connections

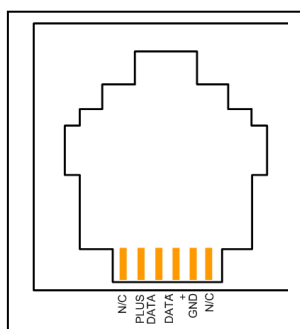

Serial Cable Permanent Connections

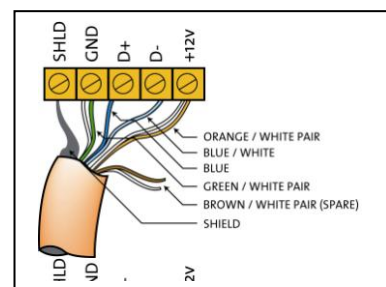

recommended cable colour coding

Green/White Pair	paralleled for GND
Orange/White Pair	paralleled for +12V
Blue/White Pair	Blue for DATA+
	White for DATA-

recommended cable types

Belden:	9503	M&M Cable:	B2003CS
Dynalite:	DYNET-STP-CABLE	M&M cable:	B9503CS
Garland:	MCP3S	Multicables:	AWME120236209220
Hartland:	HCK603	RS Components:	368-687

product specifications

Supply:	18 - 32VDC at 2.5 Amps
Load Outputs:	6 x 350mA Current Mode Common Anode LED Outputs
Output Capacity:	18 Watts Box Total, 6 Watts combined total for consecutive pairs of channels (Ch 1&2, Ch 3&4, Ch 5&6) 4 Watts per individual channel
Output Protection:	Electronic overload / short circuit protection
Supply Terminals:	1 x Plus, 1 x Minus 1 x Earth, up to 1 x 4mm ² cable per terminal
Load Terminals:	+VE, CHx for each channel, up to 1 x 4mm ² cable per terminal
IO:	1 x RS485 DyNet / DMX512 serial port
DyNet DC Supply:	100mA (capacity for approx 5 Panels)
Presets:	170
Compliance:	CE, C-Tick
Ambient Temperature:	0°C - 40°C ambient temperature 0% to 95% RH non condensing
Construction:	ABS plastic DIN rail mount
Dimensions:	Height 86mm x Width 209mm x Depth 66mm
Weight:	1Kg