

# DDBC320-DALI

## DALI HF Ballast/Switching Controller Installation Manual



### features

- **Supply** – 100-240V 50/60Hz Single Phase at 0.5A.
- **3 x DALI Outputs** – suitable for DALI HF Ballasts, electronic low-voltage transformers and LED fixtures
- **3 x Feed Thru Switched Circuits** – each rated at 20A
- **Built In DALI Bus Power Supply** – No external supply required
- **Override and Status Indicator for Each Switched Channel**
- **Dry Contact Interface** - Can be programmed to perform many different functions. The factory settings will cause this input to transmit network identification information
- **Many Control Options** - Control of this device can be via a combination of methods, eg. serial control port, relay contacts, push button wall stations, infrared receivers and time clocks
- **Simple Installation** - DIN Rail mount facilitates installation. All connection terminals are accessible without disassembly



To reduce the risk of fire or electric shock, do not expose this device to rain or moisture. Do not energise unless the front cover is in place. The device must be earthed. Installation, programming and maintenance must be carried out by qualified personnel.

**Warning** – this is a class A product. In a domestic environment this product may cause radio interference in which case the user may be required to take adequate measures.

**Special Programming** – This device is designed for professional installation only, and will only operate in basic modes unless programmed via a computer. If programming is required, contact your local agent for details. Once the data cable is connected to the devices, the factory default settings will allow any control panel to control all channels in all dimmers.

**Check Connections** – Tighten all load-carrying screw connections, as vibrations from transport can cause terminal block screws to become loose.

**Power Sources** – This device should only be operated from the type of supply specified on the front cover. This device *must* be earthed.

**Output Circuit** – The load on the switched circuits should not exceed the specified capacity of 20A, these circuits should be fed via a 20A circuit breaker.

**Load Control Circuit** – A 2-core DALI bus cable is required to be run to the loads. This cable is in addition to the mains feed.

**Load Type** - This product is intended to control DALI and Switched devices.

**Mounting Location** – Install in a dry, well-ventilated location. Controllers may emit some mechanical noise. Take this into account when deciding the mounting location.

**Data Cable** – Use screened, stranded RS485 data cable with three twisted pairs. Segregate from mains cables by 300mm minimum. Connect devices in a 'daisy chain'. A data cable that is connected to an energised device is live. Do not cut or terminate live data cables.

### electrical diagram

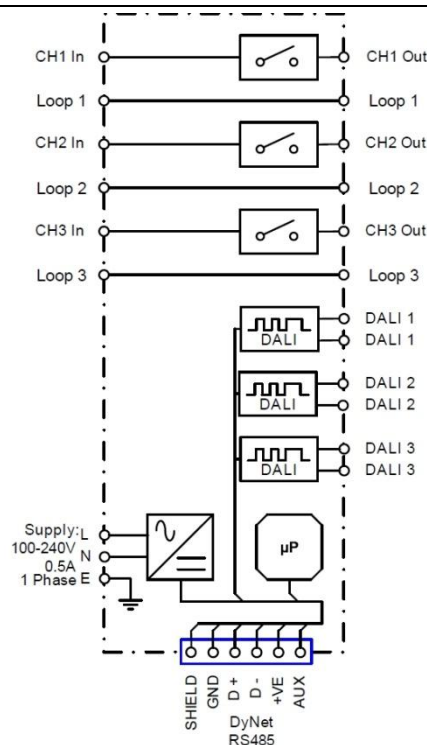

# installation steps

1. Mount the device on a DIN rail inside an approved enclosure.
2. Connect mains cables: Calculate loads to ensure the switched output is not overloaded, then connect load cables to the switched outputs. The maximum loading of this device is as follows: **Each Channel: 20A. Total Box Load: 60A.**  
Connect feeds to the feed thru Load Supply terminals, each feed can be up to 20A, and should be protected by a circuit breaker with a maximum size of 20A.  
Connect a 0.5A single phase supply to the Supply terminals, this will operate the product's electronics. This device must be earthed.
3. Connect the DALI bus cables: Use a mains rated 2 core cable to connect the DALI bus to the DALI ports on all DALI devices. The DALI bus cable should not be longer than 300 Metres, and should have a minimum cross section area based on cable length as follows:
  - Up to 100 Metres: 0.5mm<sup>2</sup>
  - 100 to 150 Metres: 0.75mm<sup>2</sup>
  - 150 to 300 Metres: 1.5mm<sup>2</sup>
 The DALI bus is not SELV and must be treated as a mains cable. It is not polarity conscious. A maximum of 64 DALI devices can be wired to each DALI port. A single DDBC320-DALI can control up to 192 DALI devices.
4. Control of the ballasts can be verified by pushing the service switch 4 times. This will invoke a chase, where all ballasts will be at 100% for 3 seconds, 40% for 3 seconds and 0% for 3 seconds off. This chase will repeat for 5 minutes after which all ballasts will return to their original state.
5. Connect data cables to the device as per diagrams below. Segregate data cables from mains cables.
6. If the Auxiliary input is to be used, connect a dry contact device in between the AUX and GND terminals. Keep cable runs between the AUX terminals and the dry contacts under two metres. The function of the Auxiliary input will need to be programmed at the time of commissioning.

## Connecting Data Cable connecting data cable

Connect Data Cable in a 'Daisy Chain'

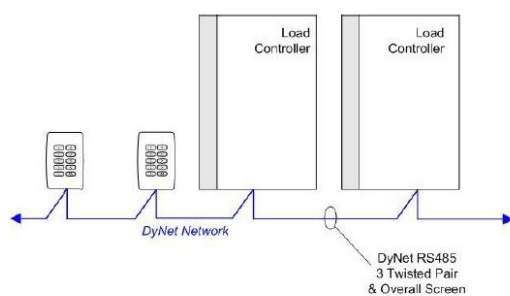

RJ12 Socket Connections

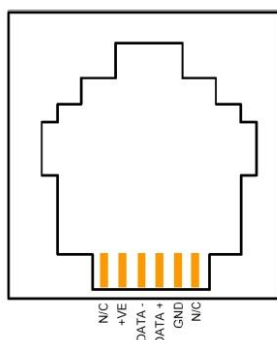

Serial Cable Permanent Connections

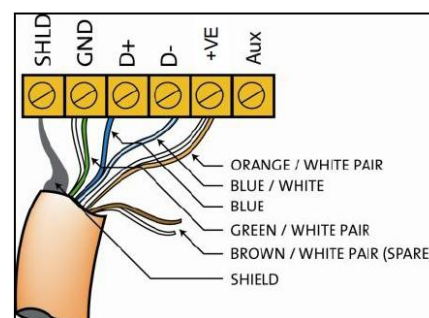

## Recommended Cable Colour Coding

<b>Green/White Pair</b>	paralleled for GND
<b>Orange/White Pair</b>	paralleled for +12V
<b>Blue/White Pair</b>	Blue for DATA+
	White for DATA-
<b>Brown/White Pair</b>	Spare, use for Shield on unshielded cable

## Recommended Cable Types

Belden:	9503	M&M cable:	B9503CS
Garland:	MCP3S	Multicables:	AWME120236209220
Hartland:	HCK603	RS Components:	368-687
M&M Cable:	B2003CS	Dynalite:	DYNET-STP-CABLE

## product specifications

<b>Supply:</b>	100-240V 50/60Hz Single Phase at 0.5A
<b>Control Outputs</b>	3 x DALI Control Outputs, each supporting a full DALI universe of 64 channels (192 total), including backward channel
<b>Mains Outputs</b>	3 x 20 Amp feed thru switched circuits for DALI ballast mains supply
<b>Supply Terminals:</b>	1 x Phase, 1 x Neutral, 1 x Earth - 1 x 4mm <sup>2</sup> max conductor size
<b>Output Terminals:</b>	3 x Ballast power circuit – Line in, Line out, Loop, Loop - 1 x 4mm <sup>2</sup> max conductor size 3 x DALI Ballast circuits - DA-, DA+ - 1 x 4mm <sup>2</sup> max conductor size
<b>Control Inputs:</b>	1 x RS485 DyNet serial port consisting of 1 x RJ12 socket & 1 x 5 way terminal strip 1 x AUX programmable dry contact input
<b>DALI BUS DC Supply:</b>	Integral 15VDC max 250mA
<b>DyNet DC Supply +VE:</b>	200mA (Supply for approx 10 panels)
<b>Preset Scenes:</b>	170
<b>Compliance:</b>	CE, C-Tick
<b>Operating Environment:</b>	0° to 40°C ambient temperature 0% to 90% RH non-condensing
<b>Construction:</b>	Polycarbonate DIN rail mount
<b>Dimensions:</b>	Height 93mm x Width 211mm x Depth 75mm
<b>Weight:</b>	0.8kg