



## sPDS-60ca

Compact power / data supply for low-voltage linear fixtures

# sPDS-60ca

## Compact power / data supply for low-voltage linear fixtures

sPDS-60ca 24 V is a compact power / data supply designed for up to 30 low-voltage linear fixtures from Philips Color Kinetics.

sPDS-60ca 24 V is compatible with both Ethernet and DMX controllers and accommodates input voltages ranging from 100 VAC to 240 VAC. All power and data connections are made via an external panel for reduced installation time. Short-circuit protection prevents failure due to incorrectly wired fixtures.

Onboard push-button controls offer the ability to address all connected fixtures, eliminating the need for additional addressing tools or software.

The sPDS-60ca 24 V enclosure is designed for use in dry locations.

### Compatible Fixtures

Fixture	Max. Quantity Per sPDS-60ca 24 V
eW Flex SLX	60 nodes
iColor Flex LMX	60 nodes
iColor Cove EC 7 in	30 fixtures
iColor Cove EC 12 in	30 fixtures
iColor Cove QLX 6 in	30 fixtures
iColor Cove QLX 12 in	20 fixtures



### Compact Power and Data for Low-Voltage Linear Installations

Provides on-board addressing capabilities and external fixture ports for easy installation, and provides power, data, and short circuit protection for up to 30 low-voltage fixtures.

## Specifications

Due to continuous improvements and innovations, specifications may change without notice.

Item	Specification	Details	
Electrical	Input Voltage	100 – 240 VAC, auto-switching, 50 / 60 Hz	
	Maximum Input Current	1.7 A at 100 VAC, 1.5 A at 120 VAC, .75 A at 240 VAC	
	Power Output	24 VDC, 62 W maximum	
Physical	Dimensions (Height x Width x Depth)	2.0 x 4.0 x 8.8 in (51 x 102 x 224 mm)	
	Weight	2.0 lb (.91 kg)	
	Construction	Aluminum case with impact-resistant, injection-molded plastic end caps, surface mount design	
	Finish	Gray and black matte	
	Connectors	Data	RJ45 input and output connectors
		Power Output	(2) 4-pin output ports
		Power Input	IEC 320 receptacle type C13, locking clamp
	Temperature Ranges	14° – 104° F (-10° – 40° C) Operating 14° – 122° F (-10° – 50° C) Startup -40° – 176° F (-40° – 80° C) Storage	
	Humidity	0 – 95%, non-condensing	
	Cooling	Thermostatically controlled fan	
	Airflow	Top cover input, back panel output	
	Heat Dissipation	25% of total power input at maximum load	
Data Input	Philips full range of controllers, third-party DMX controllers, or KiNET-compatible* third-party Ethernet controllers		
Certification and Safety	Certifications	UL / cUL, PSE	
	Classification	UL Class 2 power supply	
	Environment	Dry Location, IP20	

\* KiNET is the Ethernet lighting protocol from Philips Color Kinetics.

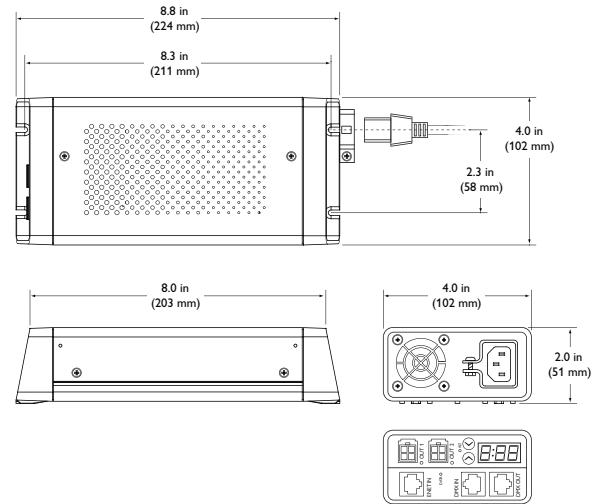

## Included in the box

- sPDS-60ca 24 V power / data supply
- (2) White clamp-on EMI suppression cores
- Black clamp-on EMI suppression cores
- DMX data terminator
- IEC power cable
- RJ45 terminator
- Installation Instructions

## Ordering Information

Item	Item Number	Philips 12NC
sPDS-60ca 24 V	109-000021-02	910503700106

Use Item Number when ordering in North America.



# Installation

sPDS-60ca is a power / data supply designed for low-voltage linear DMX and Ethernet lighting installations. sPDS-60ca uses up to 30 low-voltage fixtures from Philips Color Kinetics and delivers 62 watts of low-voltage output via two ports. It automatically accommodates input voltages ranging from 100 VAC to 240 VAC. On-board controls allow you to set fixture addresses.

## Owner / User Responsibilities

It is the responsibility of the contractor, installer, purchaser, owner, and user to install, maintain, and operate sPDS-60ca in such a manner as to comply with all applicable codes, state and local laws, ordinances, and regulations. Consult with the appropriate electrical inspector to ensure compliance.

## Plan the Installation

To streamline installation and ensure accurate configuration, start with a layout or a lighting design plan that shows the physical layout of the installation and identifies the locations of all lighting fixtures, power / data supplies, controllers, switches, and cables.

## DMX and Ethernet Configurations

sPDS-60ca can be used in either DMX or Ethernet networks. DMX is appropriate for relatively simple installations, or for installations in which groups of lights operate in unison (for example, for accent lighting, perimeter lighting, or cove lighting applications).

Typical DMX installations with fixtures from Philips Color Kinetics use a controller such as iPlayer 3, a Controller Keypad for turning lights on and off and triggering light shows, and one or more sPDS-60ca devices. sPDS-60ca devices can be connected in series to deliver DMX data from a single controller to all connected lights. Note that the maximum for DMX data run lengths is 1000 ft (305 m).

☼ Refer to the sPDS-60ca Installation Instructions for specific warning and caution statements.

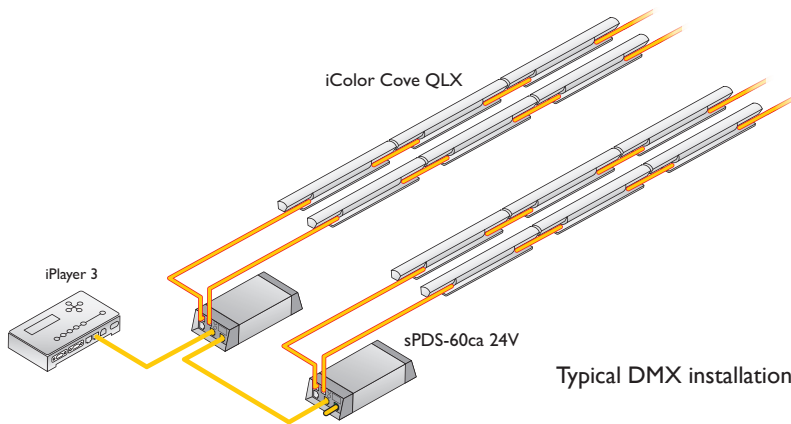
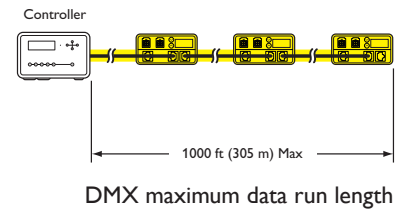



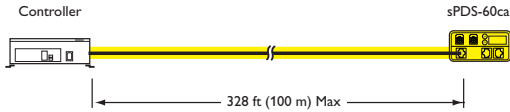

Ethernet maximum data cable length

Because it is not subject to the DMX addressing limitations, Ethernet is the preferred environment for large-scale, color-changing light shows and video displays, both of which require large numbers of unique addresses.

Typical Ethernet installations with LED lighting fixtures from Philips Color Kinetics use an Ethernet switch, an Ethernet controller (such as Light System Manager or Video System Manager Pro), one or more Ethernet Controller Keypads (for light show triggering), and one or more sPDS-60ca devices. For additional devices in a network, use additional Ethernet switch ports. Note that in Ethernet networks, the maximum data cable lengths are 328 ft (100 m) between Ethernet devices without a repeater (for example, the cable between a controller and switch, or switch and sPDS-60ca).

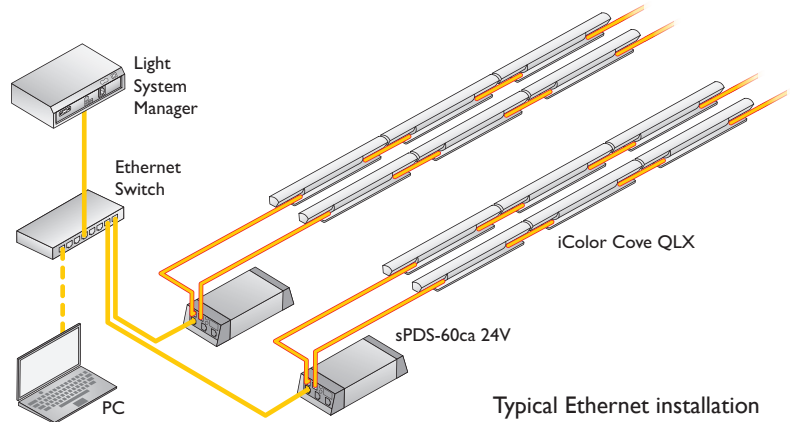

Typical Ethernet installation

## Compatible fixtures

Fixture	Max. Quantity Per sPDS-60ca 24V
eW Flex SLX	60 nodes
iColor Flex LMX	60 nodes
iColor Cove EC 7 in	30 fixtures
iColor Cove EC 12 in	30 fixtures
iColor Cove QLX 6 in	30 fixtures
iColor Cove QLX 12 in	20 fixtures

## Included in the box

sPDS-60ca 24V power / data supply
(2) White clamp-on EMI suppression cores
Black clamp-on EMI suppression core
DMX data Terminator
IEC power cable
RJ45 terminator
Installation Instructions



## Electrical Configuration Guidelines

Refer to the table at left for the quantities of each fixture that you can connect per sPDS-60ca device.

Refer to the fixture product guides for information on electrical configuration for fixtures. Each sPDS-60ca uses standard line power via an IEC inlet and power cable. You can secure the device's power cable using a locking clamp attached to the housing.

sPDS-60ca should be installed in a dry location.

## Inspect sPDS-60ca and Accessories

Carefully inspect the box containing the sPDS-60ca and the contents for any damage that may have occurred in transit.

## Assemble Additional Items

The following items are required to mount and connect the sPDS-60ca:

- The included RJ45 terminator (required in DMX lighting networks)
- The included IEC power cable
- CAT 5e or better data cable, as required
- The included black magnetic EMI suppression core (for the IEC power cable)
- The included two white magnetic EMI suppression cores (for Flex strands or fixture leader cables)
- Power screwdriver (for mounting)
- Four screws suitable for the mounting surface
- Philips screwdriver

## Mount the sPDS-60ca

Make sure the sPDS-60ca device is powered OFF before mounting and connecting. A power screwdriver is recommended.

1. Position the sPDS-60ca device in its designated mounting location. Make sure the mounting location is flat, suitable for the mounting hardware, and clear of debris and other obstructions.
2. Using four M3.5 or #6 screws suitable for the mounting surface, secure the sPDS-60ca device to the surface using the two mounting slots located at both ends of the device.

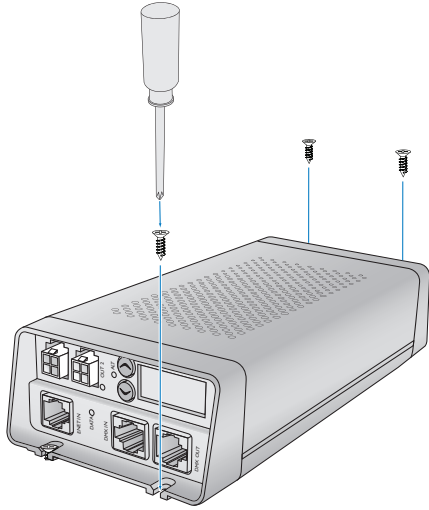

✿ Make sure that there is adequate space to make all connections to the front and rear of the device. Also, the vents at the top and rear of the device should not be obstructed.

✿ Make sure that the device is securely attached to the mounting surface and free of excessive vibration.

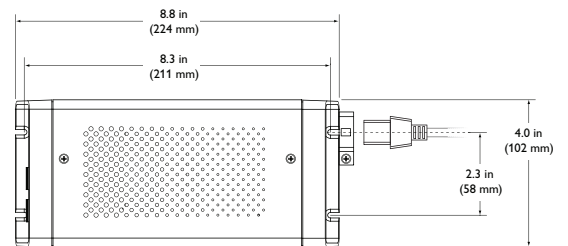

## Install EMI Suppression Cores

The sPDS-60ca ships with three EMI suppression cores. These suppression cores reduce electromagnetic noise that can interfere with other electrical equipment. The white suppression cores are for Flex strands or fixture leader cables. The black suppression core is for the IEC power cable.

Before attaching the cores, make sure that each set of ferrite metal halves are secure in their plastic housing.

1. Attach the black suppression core to the power cable:
  - Near the end of the cable that connects to the power / data supply, coil the IEC power cable into a small loop.
  - Place the section of the loop where the cord is doubled into the suppression core. Be sure the cord is securely in the core's middle.
  - Snap the core shut around the doubled cord.
2. Attach a white suppression core to the fixture strand or leader cable attached to port 1:
  - Near the connection to the power / data supply, coil the strand or cable into a small loop.
  - Place the section of the loop where the cord is doubled into the suppression core. Be sure the cord is securely in the core's middle.
  - Snap the core shut.
3. Repeat step 2 for the second white suppression core, if necessary.

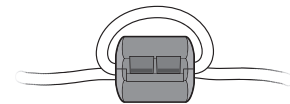
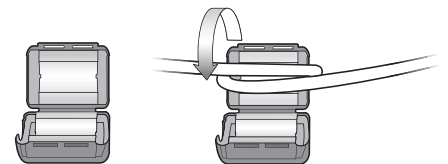
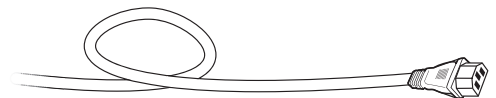

\* In DMX networks, use DMX repeaters for run lengths of over 1000 ft (325 m). Also use a DMX repeater for runs of more than 32 sPDS-60ca devices connected in series.

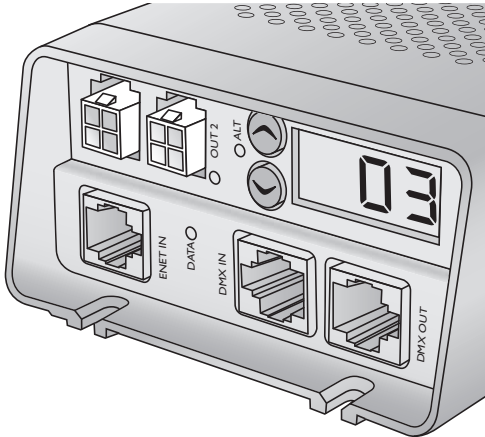

## Make Data Input Connections

sPDS-60ca has different connectors for DMX and Ethernet data inputs. The sPDS-60ca operates in either DMX or Ethernet mode, based on what data connections it detects.

### DMX

1. Using an RJ45 connector cable, connect your controller's DMX output port to the DMX IN port on the sPDS-60ca.
2. To add a second power / data supply to your DMX network, connect an RJ45 cable from the sPDS-60ca device's DMX OUT port to the DMX IN port on the second sPDS-60ca device.
3. If necessary, continue connecting sPDS-60ca devices (up to 32 without a repeater).
4. Plug the included DMX terminator into the DMX OUT port on the last sPDS-60ca in the series.

### Ethernet

- Using a CAT 5 cable, connect the ETHERNET IN port on the sPDS-60ca to an available port on an Ethernet switch connected to your lighting network.

## Connect Fixtures to the sPDS-60ca

Make sure the power is OFF before connecting fixtures to the sPDS-60ca.

- Connect a Flex strand or fixture leader cable to one of the two available ports on the front of the sPDS-60ca.

## Connect the sPDS-60ca to Line Power

1. Connect the IEC power cable to the inlet on the back of the sPDS-60ca. Make sure that you push the connector firmly past the locking clamp so that it meets the bottom of the power inlet.
2. To secure the cord, tighten the locking clamp around the inlet with a Phillips screwdriver.

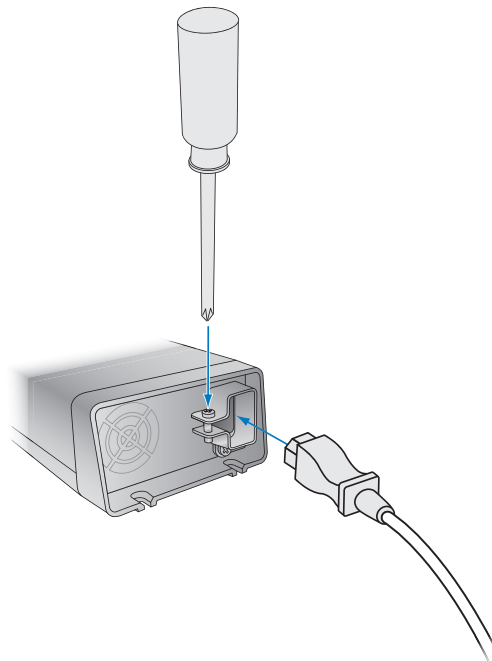

# Addressing and Controlling Fixtures

Make sure the power is ON before addressing fixtures.

Addressing methods differ depending on your environment (DMX or Ethernet). In DMX networks, sPDS-60ca devices use DMX addresses to communicate with connected fixture nodes. For color-changing fixtures, each node receives three sequential DMX addresses, one for the red channel, one for the green channel, and one for the blue channel. (eW Flex SLX nodes also receive three sequential DMX addresses, although only the red and green channels are used.) When using a sPDS-60ca device in a DMX network, fixtures are not directly programmed with DMX addresses. Instead, you use the device's on-board menu to discover connected nodes and program a base *light number*. Discovered nodes are automatically addressed in reference to the base light number.

A light number corresponds to three sequential DMX addresses. Since a DMX universe consists of 512 DMX addresses, there are 170 light numbers per universe ( $170 \times 3 = 510$ , with two DMX addresses left over). Light number 1 corresponds to DMX addresses 1, 2, and 3; light number 2 corresponds to DMX addresses 4, 5, and 6; light number 3 corresponds to DMX addresses 7, 8, and 9; and so on.

Ethernet is the preferred environment for installations requiring large numbers of individually controllable nodes, such as video displays and dynamic light shows with intricate effects. In Ethernet networks, each sPDS-60ca device comes pre-programmed with a unique IP address, so it effectively functions as its own universe. You can discover all sPDS-60ca devices in an installation using QuickPlay Pro, which automatically determines how many fixtures are connected to each output port and addresses them. Light System Manager and Video System Manager Pro, Ethernet lighting controllers from Philips Color Kinetics, also automatically discover and address all connected fixtures.

For complete details on addressing, and on using QuickPlay Pro, refer to the *Addressing and Configuration Guide*, available at [www.colorkinetics.com/support/addressing/](http://www.colorkinetics.com/support/addressing/)

✳ A node is an individual controllable fixture, or segment of a fixture. Fixtures have one or more nodes, depending on the fixture type.

✳ You can also program base light numbers using QuickPlay Pro addressing and configuration software. You can download QuickPlay Pro from [www.colorkinetics.com/support/addressing/](http://www.colorkinetics.com/support/addressing/)

## Light numbers and corresponding start DMX addresses

Light Number	1	2	3	4	5	6	7	8	9	10	...
Start DMX Address	1	4	7	10	13	16	19	22	25	28	...

## Using the On-Board Menu

The sPDS-60ca has two buttons and a three-digit display that allow you to discover and address connected nodes in a DMX network. (When connected to an Ethernet network, the on-board menu is disabled.)

### Discovering Nodes

When you connect fixtures or Flex strands to an sPDS-60ca, you must discover all connected nodes. Discovery makes the sPDS-60ca aware of its nodes so that it can assign addresses and send control data correctly.

#### ► To discover all connected nodes:

1. Press the menu's Up and Down buttons simultaneously. The connected nodes flash.
  - The display shows the number of connected nodes in two consecutive 3-digit messages, flashing once for each port. The first digit of each message shows the port number, and the next two digits show the number of nodes connected to the port. For example, if seven nodes are connected to port 1 and 13 nodes are connected to port 2, the display flashes 107, then 213.
  - If no fixtures are connected, the display flashes 100, then 200.

Once the node counts have been displayed, the display shows CFG (for configuration mode).

2. Press the Up and Down buttons simultaneously to leave configuration mode.

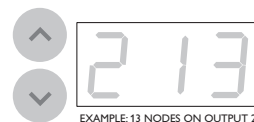
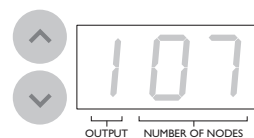





✳ *Make sure that the base light number allows enough DMX addresses for all connected nodes, or the installation will not function properly. For example, 50 connected RGB nodes require 50 light numbers when each node is controlled individually. Therefore, the base light number should be 121 or lower.*

## Setting a Base Light Number

Setting the base light number assigns a reference light number to the sPDS-60ca device. Connected nodes are automatically assigned light numbers consecutively, beginning with the base light number. Nodes connected to port 1 are addressed first. sPDS-60ca devices are factory-addressed with base light number 1.

In DMX networks with multiple sPDS-60ca devices, some care must be taken when you want each node in your network to receive a unique light number. For instance, your lighting network may have three sPDS-60ca devices, each with 25 connected iColor Cove EC fixtures. To ensure that each node receives a unique light address, assign base light number 1 to the first sPDS-60ca, base light number 26 to the next device, and base light number 51 to the third.

### ► To set the base light number:

- Press the menu's Up or Down button until you arrive at the desired base light number. (Press and hold either button to scroll rapidly through the numbers.)

## Grouping Nodes

You can group consecutive nodes together so that they operate in unison. All nodes in a group receive the same light number, and therefore the same set of DMX addresses. Grouping multiple nodes together decreases the total number of unique addresses that your installation requires, and can allow you to achieve desired effects.

### Understanding Group Settings

By default, sPDS-60ca has a group setting of +01, which means that each group contains one node. With a group setting of +01, each node receives a unique light number and is controlled individually. A group setting of +02 means that each group contains two nodes. With a group setting of +02, each pair of consecutive nodes receives the same light number. A group setting of +03 means that each group contains three consecutive nodes, and so on. The maximum group size is 20 nodes, but you can set a group setting of ALL to assign the same light number to all connected nodes (all nodes work in unison).

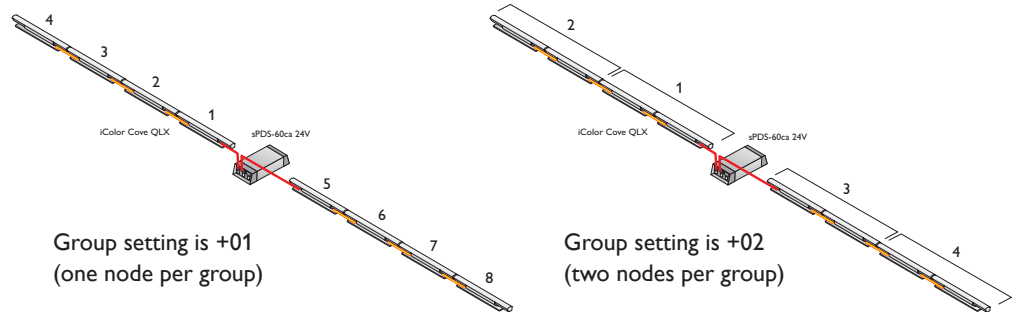

✳ *Group numbers that divide evenly into the total number of nodes in a run ensure consistency of presentation. A consistent group size can be important for the proper display of video and other dynamic light show content. Group sizes that do not divide evenly into the total number of nodes leave an inconsistently sized group at the end of a run. For example, assigning a group number of 7 to a run of 17 nodes creates two groups of seven nodes each and one smaller group of three nodes (7 + 7 + 3 = 17).*

For Ethernet-based video displays in which each fixture node functions as a pixel, you can increase the group size to increase the apparent size of each node. For example, a rectilinear video display with 10 nodes on a side contains 100 total nodes. By default, each node is assigned a unique light number can be controlled individually. If you change the group number setting to +04, each set of four consecutive nodes is assigned the same light number, proportionally increasing the size of each pixel in the video display.

### Assigning Negative Group Settings

Group settings can be positive or negative. When positive (the default), the sequence of assigned light numbers begins at port 1, continues to the end of the series of nodes connected to port 1, picks up at port 2, and continues to the end of the series of nodes on port 2.

Assigning a negative group setting changes the direction in which consecutive nodes are addressed. This can be useful if you want dynamic effects to progress in one apparent direction, or to simplify control layouts by having node addresses increment in a way that follows their physical layout.

When you assign a negative group setting, the sequence of assigned light numbers begins at the end of the series of nodes connected to port 1, continues to the node nearest to port 1, picks up at port 2, and continues to the end of the series of nodes connected to port 2.

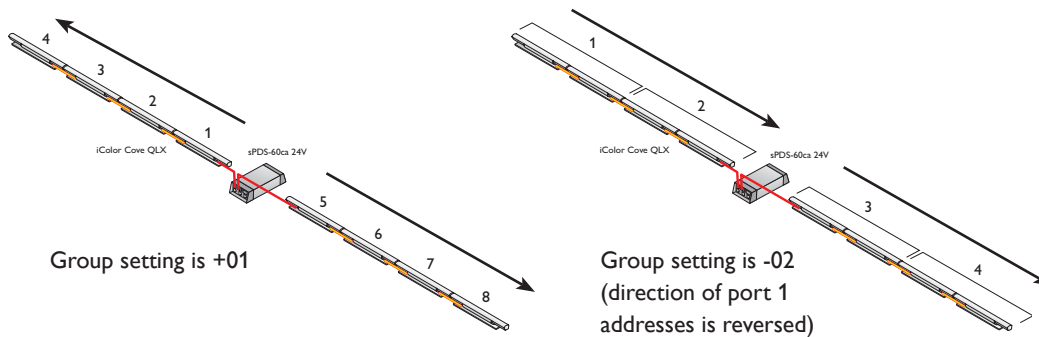

#### ► To change the group setting:

1. Press the menu's Up and Down buttons simultaneously. The display shows the number of lights on each port (as described in "Discovering Nodes" above), then reads CFG (for configuration mode).
2. Press the Up or Down arrow until you reach the desired group setting. (ALL assigns the same light number to all connected nodes.)
3. Press the Up and Down buttons simultaneously to save the new group setting and leave configuration mode.

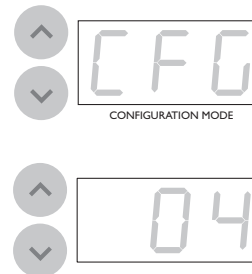





Philips Color Kinetics  
3 Burlington Woods Drive  
Burlington, Massachusetts 01803 USA  
Tel 888.385.5742  
Tel 617.423.9999  
Fax 617.423.9998  
[www.philipscolorkinetics.com](http://www.philipscolorkinetics.com)

Copyright © 2011 – 2012 Philips Solid-State Lighting Solutions, Inc. All rights reserved.  
Chromacore, Chromasic, CK, the CK logo, Color Kinetics, the Color Kinetics logo, ColorBlast, ColorBlaze, ColorBurst, eW Fuse, ColorGraze, ColorPlay, ColorReach, iW Reach, eW Reach, DIMand, EssentialWhite, eW, iColor, iColor Cove, IntelliWhite, iW, iPlayer, Optibin, and Powercore are either registered trademarks or trademarks of Philips Solid-State Lighting Solutions, Inc. in the United States and / or other countries. All other brand or product names are trademarks or registered trademarks of their respective owners. Due to continuous improvements and innovations, specifications may change without notice.  
Cover Photo: Peeps & Company, by Mark

DAS-000065-00 R01 05-12