



sPDS-480ca

Power / data supply for large-scale Ethernet installations

sPDS-480ca

Power / data supply for large-scale Ethernet installations

sPDS-480ca is a power / data supply designed for large-scale Ethernet LED lighting installations using low-voltage fixtures from Philips Color Kinetics. sPDS-480ca includes 7.5 V and 24 V versions to meet the power requirements of different fixtures.

sPDS-480ca 24 V delivers 480 watts of output via eight 60-watt ports. The 7.5 V version delivers 480 watts of output via 16 30-watt ports. Both automatically accommodate input voltages ranging from 100 VAC to 240 VAC. Short-circuit protection prevents device failure due to incorrectly wired fixtures. The standard IEC power inlet accepts both North American and international power cables.

With onboard controls, sPDS-480ca incorporates automatic fixture discovery and testing, eliminating the need for additional addressing tools or software. sPDS-480ca features a backlit LCD for easy menu viewing.

Housed in a 2U rack-mountable enclosure, sPDS-480ca includes rack handles and surface-mount brackets, for versatile mounting options.

Over-temperature detection and selectable shutdown options protect sPDS-480ca against operation beyond its rated temperature specification. Variable-speed fans keep noise levels low and include user serviceable air filters.

Compatible Fixtures

Device	Fixture	Max. Quantity Per sPDS-480ca	Max. Quantity Per Output Port
sPDS-480ca 7.5 V	iColor Flex MX	960 nodes	60 nodes
	iColor Tile MX	8 tiles	1/2 tile
sPDS-480ca 24 V	eW Flex SLX	480 nodes	60 nodes
	iColor Flex LMX	480 nodes	60 nodes
	iColor Cove EC 7 in	240 fixtures	30 fixtures
	iColor Cove EC 12 in	240 fixtures	30 fixtures
	iColor Cove QLX 6 in	240 fixtures	30 fixtures
	iColor Cove QLX 12 in	160 fixtures	20 fixtures



Versatile Power and Data for Large-Scale Ethernet Installations

Provides power to up to 240 low-voltage fixtures. Features include short-circuit protection, on-board controls, and diagnostic functions to assist with the proper operation of Philips Color Kinetics lighting systems.

Specifications

Due to continuous improvements and innovations, specifications may change without notice.

Item	Specification	sPDS-480ca 7.5 V	sPDS-480ca 24 V
Electrical	Input Voltage	100 – 240 VAC, auto-switching, 50 / 60 Hz	
	Maximum Input Current	8 A at 100 VAC, 7 A at 120 VAC, 3.5 A at 240 VAC	6 A at 100 VAC, 5 A at 120 VAC, 2.5 A at 240 VAC
	Power Output	7.5 VDC, 480 W (30 W per power port)	24 VDC, 480 W (60 W per power port)
	Fuse Rating	(16) 5 A, 125 V, 5 x 20 fast blow fuses	(8) 4 A, 125 V, 5 x 20 fast blow fuses
Physical	Dimensions (Height x Width x Depth)	3.5 x 19 x 18 in (89 x 483 x 457 mm)	
	Weight	28.7 lb (13 kg)	
	Construction	2U rack and surface-mountable aluminum chassis	
	Finish	Black matte	
	Data Connectors	RJ-45 input connector	
	Power Output Connectors	(16) 4-pin output receptacles	(8) 4-pin output receptacles
	Power Input Connectors	IEC 320 receptacle type C13, locking clamp	
	Temperature Ranges	14° – 122° F (-10° – 50° C) Operating 14° – 122° F (-10° – 50° C) Startup -40° – 176° F (-40° – 80° C) Storage	
	Humidity	0 – 95%, non-condensing	
	Airflow	Front panel input, back panel output	
	Cooling	(2) speed-configurable fans, with serviceable air filters	
	Heat Dissipation	25% of total power input	
	Data Input Source	Philips full range of Ethernet controllers, or KiNET-compatible* third-party Ethernet controller	
	Certification and Safety	Certification	UL / cUL, FCC Class A, CE, PSE
Classification		UL Class 2 power supply	
Environment		Dry Location, IP20	

* KiNET is the Ethernet lighting protocol from Philips Color Kinetics.

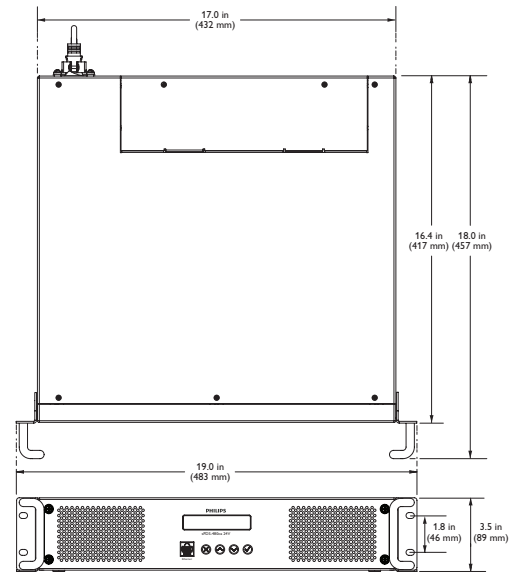

Dimensions: Rack Mount Configuration

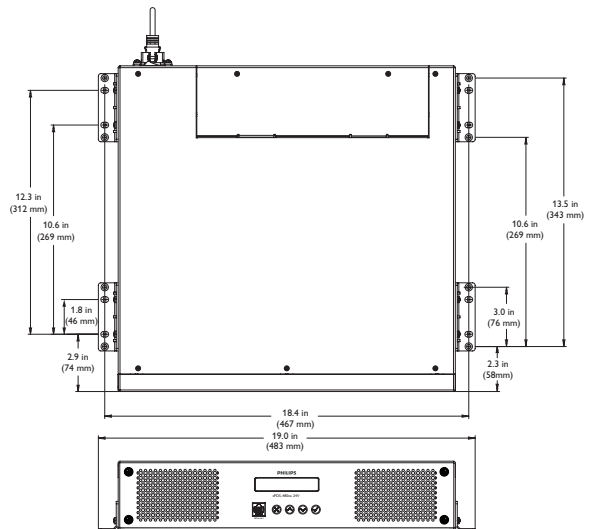

Dimensions: Surface Mount Configuration

Ordering Information

Item	Item Number	Philips 12NC
sPDS-480ca 7.5 V	109-000022-00	910503700107
sPDS-480ca 24 V	109-000026-00	910503700110

Use Item Number when ordering in North America.

sPDS-480ca 24 V

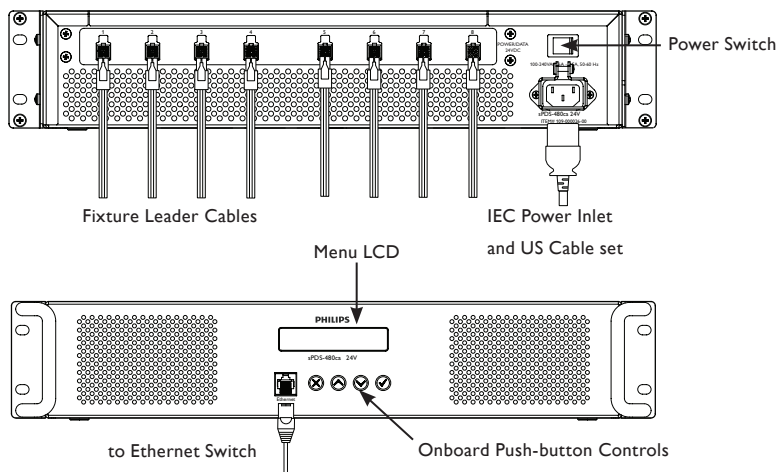

sPDS-480ca 7.5 V

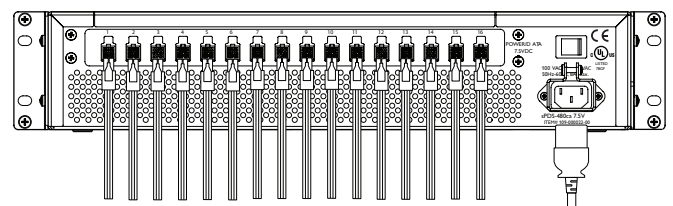

Included in the box

- sPDS-480ca power / data supply
- (2) Rack mount bracket and handles
- (2) Surface mount brackets
- (8) Screws, 0.7 X 10 mm
- (8) Lock washers

Installation

sPDS-480ca is a power / data supply designed for large-scale Ethernet LED lighting installations using low-voltage fixtures from Philips Color Kinetics. sPDS-480ca delivers 480 watts of output and automatically accommodates input voltages ranging from 100 VAC to 240 VAC. Onboard controls incorporate automatic fixture discovery, addressing, and testing. sPDS-480ca is available in 7.5 V and 24 V versions to meet the power requirements of different fixtures.

Owner / User Responsibilities

It is the responsibility of the contractor, installer, purchaser, owner, and user to install, maintain, and operate sPDS-480ca in such a manner as to comply with all applicable codes, state and local laws, ordinances, and regulations. Consult with the appropriate electrical inspector to ensure compliance.

☛ Refer to the sPDS-480ca Installation Instructions for specific warning and caution statements.

Plan the Installation

To streamline installation and ensure accurate configuration, start with a layout or a lighting design plan that shows the physical layout of the installation and identifies the locations of all lighting fixtures, power / data supplies, controllers, switches, and cables.

Ethernet Configuration

sPDS-480ca is designed for use in Ethernet networks. Typical Ethernet installations with Philips Color Kinetics LED fixtures include an Ethernet switch, an Ethernet controller such as Light System Manager or Video System Manager Pro, Ethernet Controller Keypads for light show triggering, and one or more sPDS-480ca devices.

In an Ethernet environment, each Philips Color Kinetics power / data supply has a unique IP address. Each fixture connected to the device is automatically assigned unique identifiers that controllers use to identify and manage the fixture.

☛ To connect sPDS-480ca to a DMX Controller such as iPlayer 3 or a third-party controller, use the Multi-Protocol Converter with a Power-over-Ethernet (PoE) injector or PoE switch.

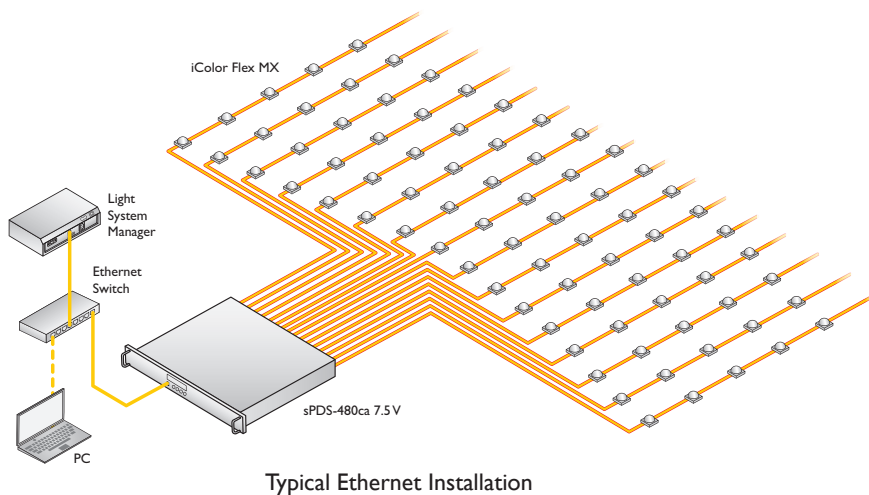

Typical Ethernet Installation

Maximum data cable lengths are 328 ft (100 m) between Ethernet devices without a repeater. The number of fixtures that each sPDS-480ca unit can support depends on the power requirements of the specific fixtures that you are using. See the table on the following page for the maximum quantities of each fixture that you can connect per device.

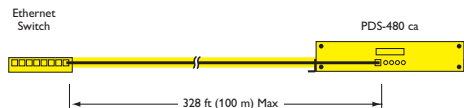

Compatible Fixtures

Device	Fixture	Max. Quantity Per sPDS-480ca	Max. Quantity Per Output Port
sPDS-480ca 7.5 V	iColor Flex MX	960 nodes	60 nodes
	iColor Tile MX	8 tiles	1/2 tile
sPDS-480ca 24 V	eW Flex SLX	480 nodes	60 nodes
	iColor Flex LMX	480 nodes	60 nodes
	iColor Cove EC 7 in	240 fixtures	30 fixtures
	iColor Cove EC 12 in	240 fixtures	30 fixtures
	iColor Cove QLX 6 in	240 fixtures	30 fixtures
	iColor Cove QLX 12 in	160 fixtures	20 fixtures

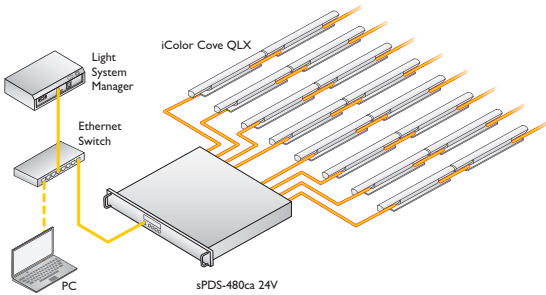

Typical iColor Cove QLX Installation

 **KiNET Ethernet** is the high performance network protocol engineered by Philips Color Kinetics for LED lighting control.

Included in the box

sPDS-480ca power / data supply

IEC power cable

(8) Lock washers

(2) Rack mount brackets with handles

(8) Screws, 0.7 X 10 mm

(2) Surface mount brackets

Electrical Configuration Guidelines

Linear fixtures such as iColor Cove EC and iColor Cove QLX can be installed in series using the fixtures' end-to-end connectors. You can install one string of Flex fixtures per port. iColor Tile MX requires two ports per fixture for a total of eight tiles on a 7.5 V sPDS-480ca.

Each sPDS-480ca connects to line power with a standard IEC inlet and power cable, which can be secured using a locking clamp located on the back of the device's housing.

The sPDS-480ca should be installed in a dry location.

Assemble Additional Items

The following items are required to mount and connect the sPDS-480ca:

- The 2 included rack mount brackets with handles (if rack mounting)
- 4 screws (typically 10-32) and lock washers suitable for mounting the device to a rack (if rack mounting)
- The 4 included surface mount brackets (if surface mounting)
- 16 screws suitable for the surface (if surface mounting)
- A power screwdriver (if surface mounting)
- A Phillips screwdriver (if surface mounting)
- The 8 included screws, 0.7 x 10 mm
- The 8 included lock washers
- The included IEC power cable
- CAT 5e or better data cable, as required

You must also have access to a dedicated Ethernet network, an Ethernet switch, and a controller that is compatible with a KiNET-based lighting system, such as Philips Color Kinetics Light System Manager, Video System Manager Pro, or ColorDial Pro.

Inspect sPDS-480ca and Accessories

Carefully inspect the box containing the sPDS-480ca and the contents for any damage that may have occurred in transit.

Mount the sPDS-480ca

Make sure the device is powered OFF before mounting and connecting.

You can rack mount the PDS-480ca or mount it to a vertical or horizontal surface. In either case, sPDS-480 must be installed in a location that allows air to move freely around the front and rear of the housing.

Rack Mount

You can mount the sPDS-480ca on a standard EIA-310-compliant rack.

1. Using the included mounting screws, attach one stainless steel handle to each pair of threaded holes located on either side of the device, just behind the faceplate. (Use two screws for each bracket.)
2. Each handle has two holes for rack mounting. Mount the device to a rack using four #10 or #12 machine screws and lock washers.

Surface Mount

A power screwdriver is recommended for surface mounting.

1. Remove the included rack mount handles from their two attached brackets using a Philips screwdriver. Together with the other two included brackets, you will now have four brackets for surface mounting.
2. Using two included screws and lock washers for each bracket, attach two mounting brackets to each side of the device. The portion of each bracket with four holes should be flush with the bottom of the device.
2. Each of the included mounting brackets mount to the surface using 4 screws each. Mount the device to the surface using 16 screws that are suitable for the mounting surface.

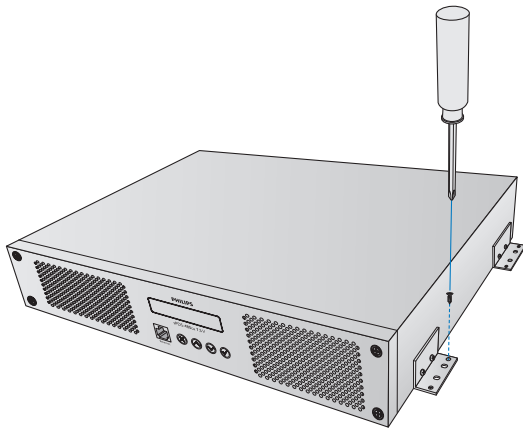

✳ Make sure that there is adequate space to make all connections to the front and rear of the device. No vents should be facing down.

✳ Make sure that the device is securely attached and free of excessive vibration.

✳ If multiple devices are mounted on a single rack, leave at least 1 RU, or 1.75 in (44 mm), between each sPDS-480ca. Also, the rack should be located in an environment with a controlled climate.

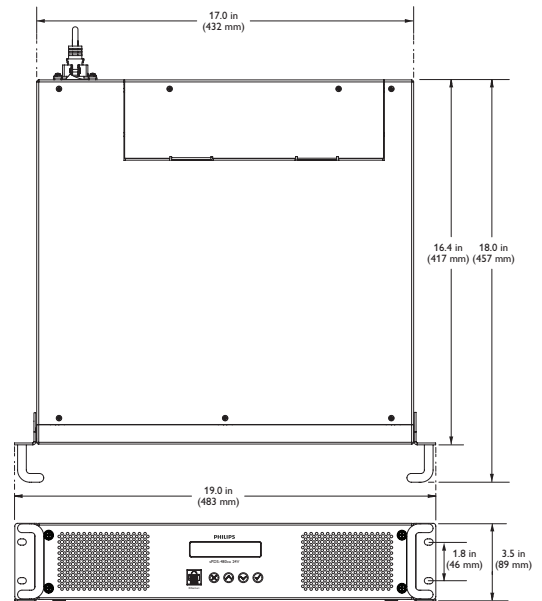

Dimensions: Rack Mount Configuration

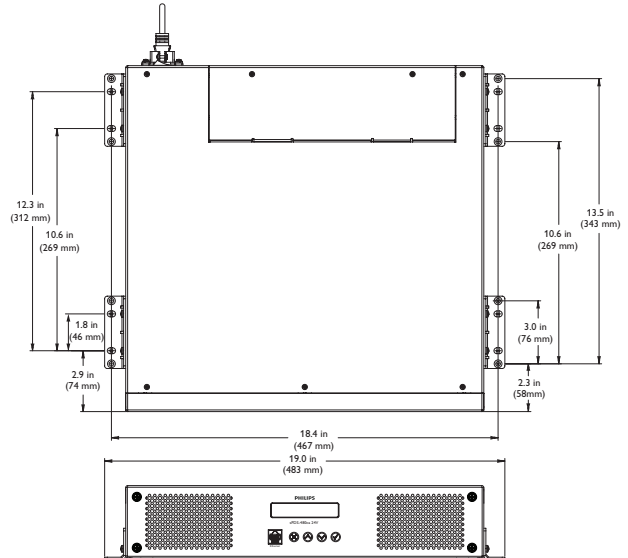

Dimensions: Surface Mount Configuration

Connect the sPDS-480ca to Line Power

1. Connect the IEC power cable to the inlet in the back of the sPDS-480ca.

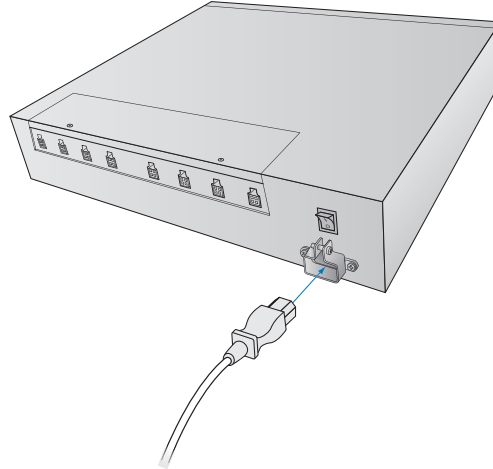

2. To secure the cord, tighten the locking clamp around the inlet with a Phillips screwdriver.
3. Connect the power cable to line power.

Connect the sPDS-480ca to Fixtures

Make sure the device is powered OFF before connecting to fixtures.

1. Connect the leader cables or Flex strands to an available port on the back of the device. Ports are labeled 1 through 8.

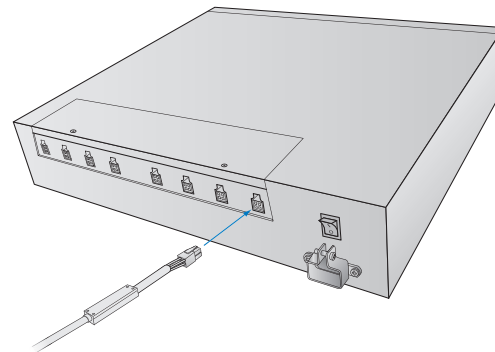

2. Power the device ON.

 You can download QuickPlay Pro from www.colorkinetics.com/support/addressing/

Note that before you can control the connected fixtures, you must discover fixtures using either the sPDS-480ca device's on-board menu (described in the next section), QuickPlay Pro software, or the discover functionality in the software for Light System Manager or Video System Manager.

Discovering fixtures finds the quantity of connected fixtures and registers them on your power / data supply.

Using the sPDS-480ca On-Board Menu

sPDS-480ca has a navigable LCD screen with three menu levels.

Menu Level			Description
1	2	3	
View Status	Network	NET: IP Address ...	Displays device's current IP address
		MAC Address	Displays device's MAC address
		Data Rate	Displays an estimate of network bandwidth currently used by the device
		Serial Number	Displays the device's serial number
	Lights	Lights Per Port	Displays the nodes scanned for each port
	Temperature	Internal Temp	Displays an estimate of the device's internal temperature
		Min / Max Temp	Displays minimum and maximum temperature since device was last turned on
Fan Status		Displays whether fan is on or off, and speed of fan as percentage of maximum	

Configure	Set IP Address	10.X.X.X	Modifies the device's IP address
	Scan Lights	<i>Press Select</i>	Discovers and counts the nodes connected to each port
	Fan Settings	Low	Sets fans to run continuously at the selected speed. If temperature rise is detected, fan speed automatically switches to High until the temperature reaches a safe level.
		Medium	
		High	
		Auto*	
	Thermal Settings	Turn Lights Off*	If device overheats, lights turn off
		Ramp Down Lights	If device overheats, lights smoothly fade out
		Stay On	If device overheats, lights remain on
	LCD Backlight	Bright	Sets the brightness of the device's LCD backlight
Medium*			
Dim			
Auto-Dim		Dims the LCD backlight when no buttons have been pressed for 15 seconds	
Restore Defaults	<i>Press Select</i>	Restores factory default settings for LCD Backlight, Fan Settings, and Thermal Settings. Network configuration is unaffected.	

Test	Test Lights	All Off	Turns off all nodes
		All Red	Turns on all channels of a particular color
		All Green	
		All Blue	
		All White	
	Rainbow	Cycles through red, green, and blue, showing waves of different colors across all nodes	
	Single Port	Turns on nodes connected to one port. Press Select to begin test. Press the Down button to begin automatically cycling through the device's ports. Press the Down button again to manually cycle through the device's ports.	
	Single Light	Turns on a single node. Press Select to begin test. Press the Down button to begin automatically cycling through the connected nodes. Press the Down button again to manually cycle through the connected nodes.	

Reset System	<i>Press Select</i>	Resets the device. This has the same effect as powering it down and turning it back on. Your configured settings are unaffected.
About	<i>Press Select</i>	Displays system information, including unit model, serial number, and firmware revision number

* Default settings.

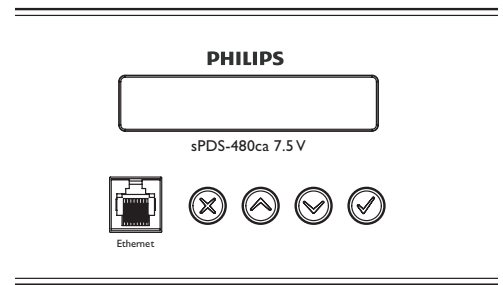

To navigate the on-board menu:

- Press the Up and Down buttons (▲ ▼) to move up and down in the current menu's set of options.
- Press the Select button (✓) to select a menu item or display its submenu.
- Press the Cancel button (X) to return to the previous menu level.

✳️ A node is an individually controllable fixture, or fixture segment, on your lighting network. Fixtures have one or more controllable nodes, depending on the fixture type.

✳️ For more on fixture discovery and addressing, refer to the Addressing and Configuration Guide available online at www.colorkinetics.com/support/addressing/

✳️ The IP addresses 10.1.3.100 and 10.1.3.101 are reserved and are not available as addresses.

✳️ Make sure you confirm the address changes. If you leave the menu option without confirming your change, it does not go into effect.

Scanning Lights

You can scan the nodes attached to the device's ports to discover fixtures and confirm that they are connected and receiving data. The discovery determines the quantity of connected nodes and registers them on your power / data supply. The power / data supply then assigns DMX addresses to uniquely identify each node, which controllers can use to perform video and light shows.

► To scan lights:

1. Press Select to activate the sPDS-480ca menu.
2. Select Configure.
3. Select Scan Lights. The LCD menu displays "scanning..."
4. When scanning finishes, you can confirm that your light fixtures are successfully connected by using the Up and Down buttons to scroll through the number of nodes for each port.

Changing an IP Address

Each sPDS-480ca comes factory-set with a unique IP address. If necessary, you can change a fixture's IP address. To ensure that fixtures function properly, make sure that the IP addresses of all sPDS-480ca devices within a single installation are unique.

► To change an IP address on an sPDS-480ca:

1. Press Select to activate the sPDS-480ca menu.
2. Select Configure.
3. Select Set IP Address.
4. Use the Up and Down buttons to change the second IP byte field. (The first IP byte field is not editable.)
5. Press Select. The cursor moves to the next byte field.
6. Repeat steps 4 and 5 for each of the next two fields, as necessary.
7. Press Select. Press Select again to confirm changes.

Testing

The test commands verify that the device, its connected fixtures, and cooling fans are operating properly.

► To test lights and fans:

1. Press Select to activate the sPDS-480ca menu.
2. Select Test. The first test command turns all lights off.
3. Press the Down button. If you have RGB fixtures, the All Red test command turns on the red LED channel of all connected fixtures.
4. Continue to cycle through the Green, Blue, White, and Rainbow test commands.
5. At the Single Port option, press the Down button once to begin automatically cycling through the device's ports and nodes. Press the Down button a second time to cycle through the ports and nodes manually.
6. At the Single Light option, press the Down button to begin automatically cycling through the device's nodes. Press the Down button a second time to cycle through the nodes manually.
7. The Fans on Full option tests both fans at full speed.

Adjusting Thermal Settings

Thermal settings determine how the device behaves if overheating occurs. The device's LCD screen flashes in case of overheating. Turn Lights Off sets lights to black when overheating occurs. Ramp Down Lights smoothly reduces brightness in case of overheating. With either of these settings, lights return to normal operation when the device's temperature returns to safe levels. Stay On continues running lights even if overheating occurs.

► To adjust thermal settings:

1. Press Select to activate the sPDS-480ca menu.
2. Select Configure.
3. Select Thermal Settings.
4. Use the Up and Down buttons to find the desired thermal setting, then press Select.

Cleaning the sPDS-480ca Air Intake Filter

To prevent overheating, inspect the air intake filter regularly and clean as needed. The air intake filters are located behind the device's front faceplate.

1. Disconnect line power from the device.
2. Using a Phillips screwdriver, loosen the four captive screws on the front of the device. Pull the faceplate out from the front of the device.

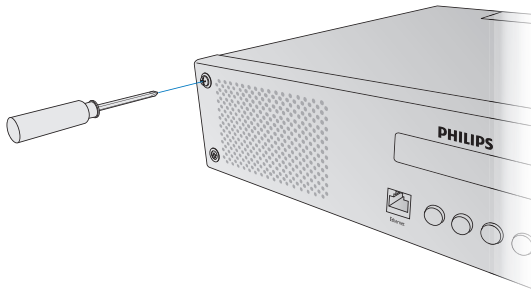

3. Remove the filters by sliding them up, then pulling them out.
4. Remove the filters from the filter covers, clean them with a vacuum or with water (then air dry them completely).

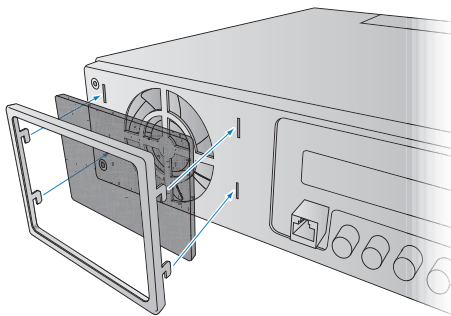

5. Place each filter in its cover, then replace the two filters on the front of the device.
6. Replace the faceplate on the device.

 Never operate the sPDS-480ca with the faceplate off.

Replacing Fuses

sPDS-480ca has a fuse for each of its ports, protecting each port from excessive current. Always replace blown fuses with the same rated fuse:

Device	Number of Fuses	Replacement Fuse
sPDS-480ca 7.5 V	16	5 A, 125 V, 5 x 20 fast blow fuse
sPDS-480ca 24 V	8	4 A, 125 V, 5 x 20 fast blow fuse

1. Make sure that the device's power is OFF.
2. Using a Phillips screwdriver, unscrew the two screws holding the cover in place. Lift the back side of the cover first, then remove it.

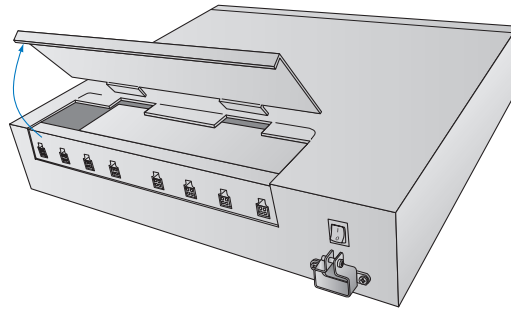

3. Remove the blown fuse from its metal clips. (The blown fuse is adjacent to the port of the fixtures that failed.)

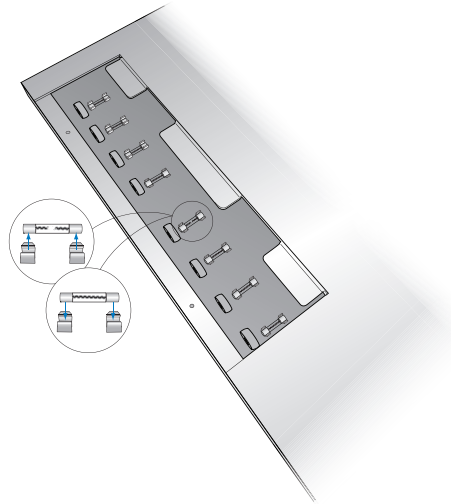

4. Replace the fuse with a new, identically-rated fuse.
5. Replace the cover and screws to close the fuse box.



Philips Color Kinetics
3 Burlington Woods Drive
Burlington, Massachusetts 01803 USA
Tel 888.385.5742
Tel 617.423.9999
Fax 617.423.9998
www.philipscolorkinetics.com

Copyright © 2011 – 2013 Philips Solid-State Lighting Solutions, Inc. All rights reserved.
Chromacore, Chromasic, CK, the CK logo, Color Kinetics, the Color Kinetics logo, ColorBlast,
ColorBlaze, ColorBurst, eW Fuse, ColorGraze, ColorPlay, ColorReach, iW Reach, eW Reach,
DIMand, EssentialWhite, eW, iColor, iColor Cove, IntelliWhite, iW, iPlayer, Optibin, and Powercore
are either registered trademarks or trademarks of Philips Solid-State Lighting Solutions, Inc. in
the United States and / or other countries. All other brand or product names are trademarks
or registered trademarks of their respective owners. Due to continuous improvements and
innovations, specifications may change without notice. DAS-000066-00 R03 04-13