



# iW Burst Powercore

Architectural and landscape LED spotlight with intelligent white light

# iW Burst Powercore

## Architectural and landscape LED spotlight with intelligent white light

iW Burst Powercore is a high-output, exterior-rated LED spotlight designed for accent and site lighting. iW Burst Powercore combines channels of warm and cool LEDs to offer variable color temperatures ranging from 2700 K – 6500 K. Architectural and Landscape versions support a range of uplighting, floodlighting, and decorative lighting applications.

- Integrates patented Powercore technology — Powercore rapidly, efficiently, and accurately controls power output to fixtures directly from line voltage, eliminating the need for an external power supply. Contractor-friendly installation dramatically simplifies installation and lowers total system cost.
- Flexible mounting in architectural applications — Architectural fixtures feature an integrated yoke with canopy base for mounting to standard US junction boxes or directly to a flat surface or substrate as local codes permit.
- Support for a wide range of landscape applications — Landscape fixtures feature a 1/2 in NPT threaded post for mounting to standard junction boxes and third-party mounting accessories such as stanchion mounts, posts, and stakes for use in softscape and hardscape applications.
- Wide range of color temperature and brightness — Channels of warm white and cool white LEDs produce color temperatures ranging from 2700 K – 6500 K.
- Exchangeable optics and accessories — Available 14°, 23°, 41°, and asymmetric 10° x 41° spread lenses project a soft-edge beam to support a wide range of lighting applications. Native 8° beam angle offers extended light projection. Available glare shields block spill light, while honeycomb louvers limit the spread of light for a more focused and intense beam.
- Versatile light positioning — Fixtures can tilt through a full 180°. Architectural fixtures also rotate through a full 360° for precise aiming.
- Universal power input range — Accepts a universal power input range of 100 – 240 VAC, allowing long fixture runs and consistent installation in any location around the world.
- Outdoor rated — With a rugged, die-cast aluminum housing fully sealed for maximum fixture life and IP66-rated for outdoor applications, iW Burst Powercore is ideal for use in damp or wet locations.



### Two Versions, Two Sizes

iW Burst Powercore Architectural and Landscape fixtures are available in standard and compact sizes for all accent and site lighting needs.

# Photometrics

Photometric data is based on test results from an independent NIST traceable testing lab. IES data is available at [www.philipscolorkinetics.com/support/ies](http://www.philipscolorkinetics.com/support/ies).

## iW Burst Powercore 8° primary optic

Lumens	1093
Efficacy	36.6 lm / W

### Polar Candela Distribution

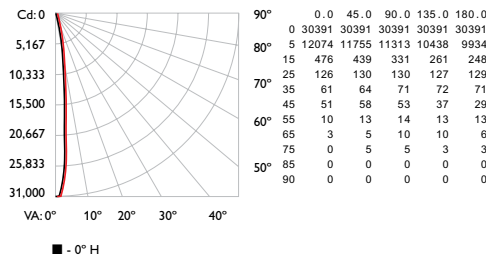

### Illuminance at Distance

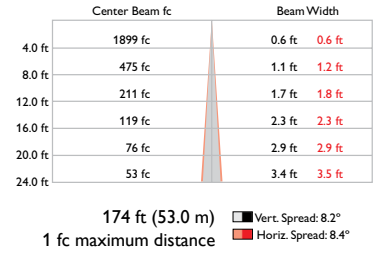

### Zonal Lumen

ZONE	LUMENS	%FIXT
0- 30	994	91.0
0- 40	1039	95.1
0- 60	1082	99.0
0- 90	1093	100.0
90-180	0	0.0
0-180	1093	100.0

### Coefficients Of Utilization - Zonal Cavity Method

RC	80				70				50				Effective Floor Cavity Reflectance: 20%			
	RW	70	50	30	10	70	50	30	10	50	30	10	50	30	10	0
0	119119119119	116116116116	111111111111	106106106	102102102	100										
1	116114112111	113112110109	108107106	104103102	10110099	98										
2	113109107105	111108105103	105103101	10210099	999897	96										
3	110106103100	10810410299	10210098	1009896	989695	94										
4	1071039997	1061029996	1009795	989694	969593	92										
5	1051009794	104999694	989593	969492	959392	91										
6	103989592	102979492	969391	959391	949290	89										
7	101969391	100969390	959290	949189	939189	88										
8	100959189	99949189	939189	929088	929088	87										
9	98939088	97939088	928987	918987	918987	86										
10	97928987	96918987	918887	908886	908886	85										

## iW Burst Compact Powercore 8° primary optic

Lumens	709
Efficacy	32.5 lm / W

### Polar Candela Distribution

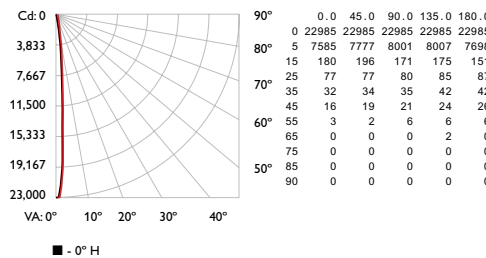

### Illuminance at Distance

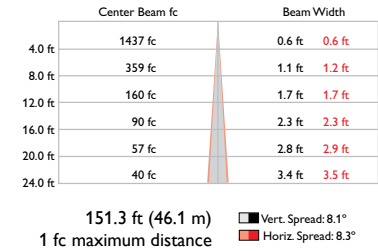

### Zonal Lumen

ZONE	LUMENS	%FIXT
0- 30	664	93.6
0- 40	688	97.1
0- 60	708	99.9
0- 90	709	100.0
90-180	0	0.0
0-180	709	100.0

### Coefficients Of Utilization - Zonal Cavity Method

RC	80				70				50				Effective Floor Cavity Reflectance: 20%			
	RW	70	50	30	10	70	50	30	10	50	30	10	50	30	10	0
0	119119119119	116116116116	111111111111	106106106	102102102	100										
1	116114113111	114112111110	108107106	105104103	101101100	98										
2	113110108106	111109107105	106104102	103101100	1009998	97										
3	111107104102	109106103101	103101100	10110098	999897	96										
4	10810410199	10710310198	1019997	1009896	989795	94										
5	1061029997	1051019896	1009796	989695	979594	93										
6	1051009795	1041009795	989694	979593	969493	92										
7	103989593	102989593	979593	969492	959392	91										
8	102979492	101979492	969392	959391	949291	90										
9	100969391	100959391	959291	949290	949290	90										
10	99959290	99949290	949190	939190	939189	89										

For lux multiply fc by 10.7

## iW Burst Powercore 14° spread lens

Lumens	960
Efficacy	32.2 lm / W

### Polar Candela Distribution

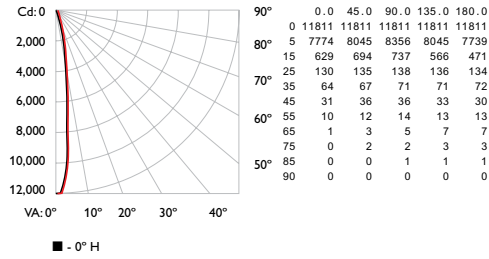

### Illuminance at Distance

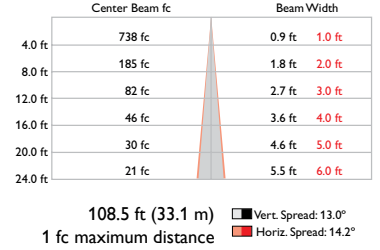

### Zonal Lumen

ZONE	LUMENS	%FIXT
0- 30	872	90.8
0- 40	915	95.3
0- 60	953	99.3
0- 90	960	100.0
90-180	0	0.0
0-180	960	100.0

### Coefficients Of Utilization - Zonal Cavity Method

RC	Effective Floor Cavity Reflectance: 20%											
	80		70		50		30		10		0	
RW	70	50	30	10	70	50	30	10	50	30	10	0
0	119119119119	119119119119	116116116116	111111111111	106106106	102102102	100					
1	115113112110	113111110108	107106105	104103102	10010099	97						
2	112109106104	110107105102	104102100	10110098	989796	95						
3	10910510199	10710310098	1019996	999795	979594	92						
4	1061019895	1051009794	989693	979492	959391	90						
5	104989592	102989492	969391	959290	939189	88						
6	101969289	100959289	949189	939088	928988	87						
7	99949087	98939087	928987	918886	908886	85						
8	97928886	96918885	908785	898785	898685	84						
9	95908684	95898684	898684	888583	878583	82						
10	94888583	93888582	878482	878482	868482	81						

## iW Burst Compact Powercore 14° spread lens

Lumens	622
Efficacy	28.5 lm / W

### Polar Candela Distribution

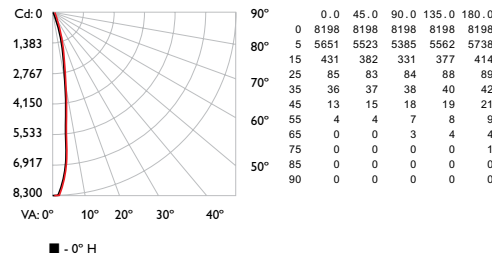

### Illuminance at Distance

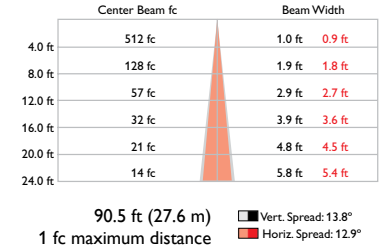

### Zonal Lumen

ZONE	LUMENS	%FIXT
0- 30	576	92.6
0- 40	600	96.5
0- 60	620	99.7
0- 90	622	100.0
90-180	0	0.0
0-180	622	100.0

### Coefficients Of Utilization - Zonal Cavity Method

RC	Effective Floor Cavity Reflectance: 20%											
	80		70		50		30		10		0	
RW	70	50	30	10	70	50	30	10	50	30	10	0
0	119119119119	116116116116	111111111111	106106106	102102102	100						
1	116114112110	113112110109	108106105	104103102	10110099	98						
2	112109107104	110108105103	105103101	10210099	999897	96						
3	109105102100	10810410199	1029998	1009896	979695	93						
4	1071029996	1051019896	999795	989594	969493	92						
5	104999693	103999593	979492	969392	949291	90						
6	102979491	101969391	959290	949290	939189	88						
7	100959289	99949189	939188	929088	928988	87						
8	98939087	98938987	928987	918887	908886	86						
9	97918886	96918886	908886	898785	898785	84						
10	95908785	95908784	898684	888684	888684	83						

For lux multiply fc by 10.7



iW Burst Powercore  
23° spread lens

Lumens	961
Efficacy	32.2 lm / W

Polar Candela Distribution

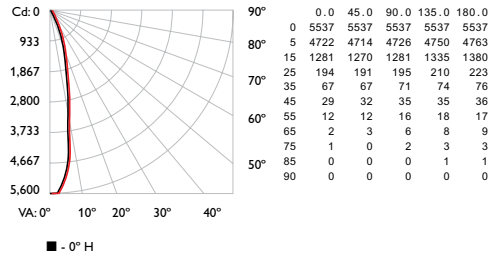

Illuminance at Distance

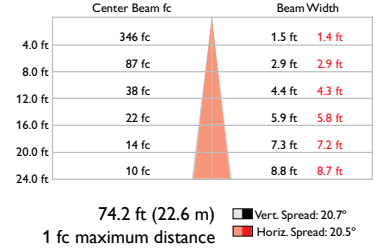

Zonal Lumen

ZONE	LUMENS	%FIXT
0- 30	866	90.2
0- 40	912	95.0
0- 60	952	99.1
0- 90	961	100.0
90-180	0	0.0
0-180	961	100.0

Coefficients Of Utilization - Zonal Cavity Method

RC	80			70			50			Effective Floor Cavity Reflectance: 20%					
	RW	70	50	30	10	0	70	50	30	10	0	50	30	10	0
0	119119119119	116116116116	111111111111	106106106	102102102	100									
1	115113111109	113111109107	107105104	103102101	100	99	98	96	93						
2	111107104102	109106103100	102100	98	100	98	96	97	96	94	93				
3	107103	99	96	106101	98	95	99	96	94	96	94	92	94	92	91
4	104	98	94	91	102	97	94	91	95	92	90	94	91	89	88
5	101	95	91	88	99	94	90	87	92	89	86	91	88	86	84
6	98	92	87	84	97	91	87	84	90	86	84	88	85	83	81
7	95	89	85	82	94	88	84	81	87	84	81	86	83	81	79
8	93	86	82	79	92	86	82	79	85	81	79	84	81	78	77
9	90	84	80	77	90	83	79	77	83	79	77	82	79	76	75
10	88	82	78	75	87	81	77	75	81	77	75	80	77	74	73

iW Burst Compact Powercore  
23° spread lens

Lumens	621
Efficacy	28.5 lm / W

Polar Candela Distribution

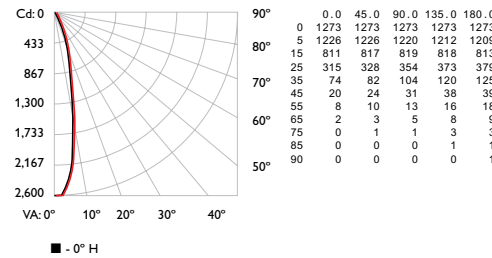

Illuminance at Distance

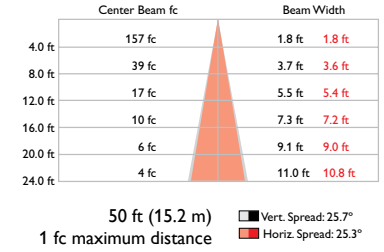

Zonal Lumen

ZONE	LUMENS	%FIXT
0- 30	560	90.1
0- 40	591	95.2
0- 60	616	99.2
0- 90	621	100.0
90-180	0	0.0
0-180	621	100.0

Coefficients Of Utilization - Zonal Cavity Method

RC	80			70			50			Effective Floor Cavity Reflectance: 20%					
	RW	70	50	30	10	0	70	50	30	10	0	50	30	10	0
0	119119119119	116116116116	111111111111	106106106	102102102	100									
1	115112110109	112110108107	106105104	103101100	100	99	98	96	93						
2	110107103101	108105102100	102	99	97	99	97	95	96	95	93	92			
3	107101	98	94	105100	97	94	98	95	92	95	93	91	93	91	88
4	103	97	93	89	101	96	92	89	94	91	88	92	89	87	85
5	99	93	89	85	98	92	88	85	91	87	84	89	86	84	82
6	96	89	85	82	95	89	85	81	87	84	81	86	83	80	79
7	93	86	82	79	92	86	81	78	84	81	78	83	80	78	76
8	90	83	79	76	89	83	79	76	82	78	75	81	78	75	74
9	88	81	76	73	87	80	76	73	79	76	73	79	75	72	71
10	85	78	74	71	84	78	74	71	77	73	71	76	73	70	69

For lux multiply fc by 10.7

## iW Burst Powercore 41° spread lens

Lumens	919
Efficacy	30.8 lm / W

### Polar Candela Distribution

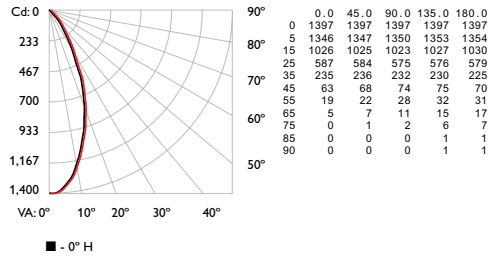

### Illuminance at Distance

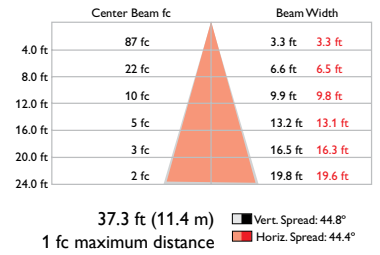

### Zonal Lumen

ZONE	LUMENS	%FIXT
0- 30	672	73.2
0- 40	821	89.3
0- 60	904	98.3
0- 90	919	100.0
90-120	0	0.0
90-130	0	0.0
90-150	0	0.0
90-180	0	0.0
0-180	919	100.0

### Coefficients Of Utilization - Zonal Cavity Method

RC	80				70				50				Effective Floor Cavity Reflectance: 20%			
	RW	70	50	30	10	70	50	30	10	50	30	10	50	30	10	0
0	1	1	1	1	1	1	1	1	1	1	1	1	1	1	1	1
1	1	1	1	1	1	1	1	1	1	1	1	1	1	1	1	1
2	1	1	1	1	1	1	1	1	1	1	1	1	1	1	1	1
3	1	1	1	1	1	1	1	1	1	1	1	1	1	1	1	1
4	1	1	1	1	1	1	1	1	1	1	1	1	1	1	1	1
5	1	1	1	1	1	1	1	1	1	1	1	1	1	1	1	1
6	1	1	1	1	1	1	1	1	1	1	1	1	1	1	1	1
7	1	1	1	1	1	1	1	1	1	1	1	1	1	1	1	1
8	1	1	1	1	1	1	1	1	1	1	1	1	1	1	1	1
9	1	1	1	1	1	1	1	1	1	1	1	1	1	1	1	1
10	1	1	1	1	1	1	1	1	1	1	1	1	1	1	1	1

## iW Burst Compact Powercore 41° spread lens

Lumens	609
Efficacy	27.9 lm / W

### Polar Candela Distribution

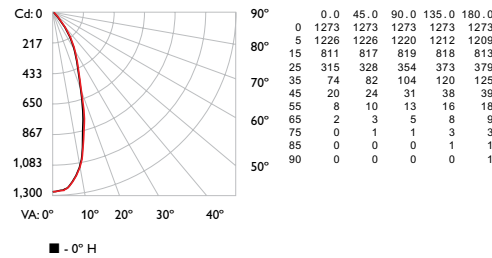

### Illuminance at Distance

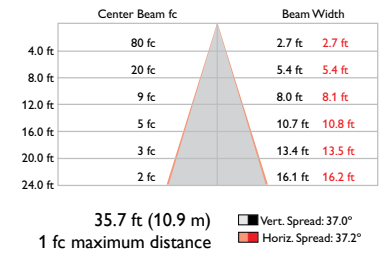

### Zonal Lumen

ZONE	LUMENS	%FIXT
0- 30	497	81.6
0- 40	564	92.6
0- 60	601	98.7
0- 90	609	100.0
90-120	0	0.0
90-130	0	0.0
90-150	0	0.0
90-180	0	0.0
0-180	609	100.0

### Coefficients Of Utilization - Zonal Cavity Method

RC	80				70				50				Effective Floor Cavity Reflectance: 20%			
	RW	70	50	30	10	70	50	30	10	50	30	10	50	30	10	0
0	1	1	1	1	1	1	1	1	1	1	1	1	1	1	1	1
1	1	1	1	1	1	1	1	1	1	1	1	1	1	1	1	1
2	1	1	1	1	1	1	1	1	1	1	1	1	1	1	1	1
3	1	1	1	1	1	1	1	1	1	1	1	1	1	1	1	1
4	1	1	1	1	1	1	1	1	1	1	1	1	1	1	1	1
5	1	1	1	1	1	1	1	1	1	1	1	1	1	1	1	1
6	1	1	1	1	1	1	1	1	1	1	1	1	1	1	1	1
7	1	1	1	1	1	1	1	1	1	1	1	1	1	1	1	1
8	1	1	1	1	1	1	1	1	1	1	1	1	1	1	1	1
9	1	1	1	1	1	1	1	1	1	1	1	1	1	1	1	1
10	1	1	1	1	1	1	1	1	1	1	1	1	1	1	1	1

For lux multiply fc by 10.7

iW Burst Powercore  
10° x 41° spread lens

Lumens	980
Efficacy	33.1 lm / W

Polar Candela Distribution

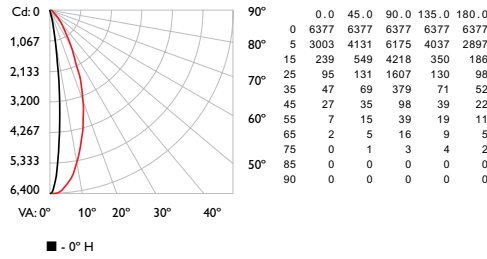

Illuminance at Distance

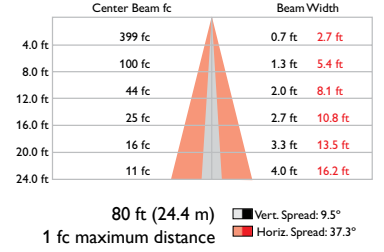

Zonal Lumen

ZONE	LUMENS	%FIXT
0- 30	851	86.8
0- 40	920	93.8
0- 60	970	99.0
0- 90	980	100.0
90-180	0	0.0
0-180	980	100.0

Coefficients Of Utilization - Zonal Cavity Method

RC	80			70			50			30			10			Effective Floor Cavity Reflectance: 20%
	RW	70	50	30	10	70	50	30	10	50	30	10	50	30	10	
0	119119119119	116116116116	111111111111	106106106	102102102	100										
1	115112110108	112110108107	106105103	102101100	99 98 97 96											
2	110106103100	108105102 99	102 99 97	99 97 95	96 94 93 92											
3	106101 97 94	104100 96 93	97 94 92	95 92 90	93 91 89 88											
4	102 97 92 89	101 95 91 88	93 90 87	92 89 86	90 87 85 84											
5	99 92 88 85	98 92 87 84	90 86 84	88 85 83	87 84 82 81											
6	96 89 84 81	94 88 84 81	87 83 80	86 82 80	84 81 79 78											
7	93 86 81 78	92 85 81 78	84 80 77	83 79 77	82 79 77 75											
8	90 83 78 75	89 82 78 75	81 77 75	80 77 74	79 76 74 73											
9	87 80 76 73	86 80 75 72	79 75 72	78 75 72	77 74 72 71											
10	85 78 73 70	84 77 73 70	77 73 70	76 72 70	75 72 70 69											

iW Burst Compact Powercore  
10° x 41° spread lens

Lumens	637
Efficacy	29.2 lm / W

Polar Candela Distribution

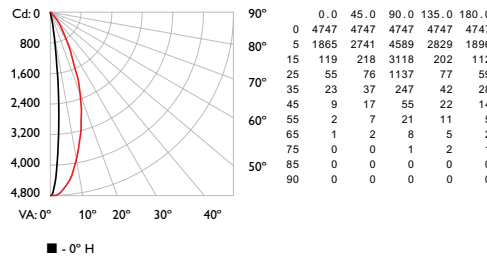

Illuminance at Distance

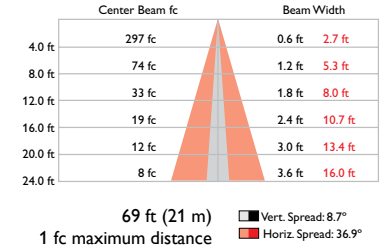

Zonal Lumen

ZONE	LUMENS	%FIXT
0- 30	565	88.7
0- 40	605	95.0
0- 60	632	99.2
0- 90	637	100.0
90-180	0	0.0
0-180	637	100.0

Coefficients Of Utilization - Zonal Cavity Method

RC	80			70			50			30			10			Effective Floor Cavity Reflectance: 20%
	RW	70	50	30	10	70	50	30	10	50	30	10	50	30	10	
0	119119119119	116116116116	111111111111	106106106	102102102	100										
1	115113110109	112110109107	106105104	103102101	99 99 98 96											
2	111107104101	109105102100	102100 98	99 97 96	96 95 94 92											
3	107102 98 95	105100 97 94	98 95 93	96 93 91	94 92 90 89											
4	103 97 93 90	102 96 92 89	94 91 88	92 90 87	91 88 86 85											
5	100 94 89 86	98 93 89 86	91 87 85	89 86 84	88 85 83 82											
6	97 90 86 82	95 89 85 82	88 84 82	87 84 81	86 83 81 79											
7	94 87 82 79	93 86 82 79	85 81 79	84 81 78	83 80 78 77											
8	91 84 80 77	90 84 79 77	83 79 76	82 78 76	81 78 76 75											
9	89 81 77 74	88 81 77 74	80 77 74	80 76 74	79 76 74 73											
10	86 79 75 72	85 79 75 72	78 74 72	77 74 72	77 74 72 71											

For lux multiply fc by 10.7

# iW Burst Powercore Specifications

Due to continuous improvements and innovations, specifications may change without notice.

Item	Specification	Details	
Output	Beam Angle	8° primary optic 14° / 23° / 41° spread lenses 10° x 41° asymmetric spread lens	
	Color Temperature*	2700 K – 6500 K	
	Lumens†	1093 (8°) 960 (14°) 961 (23°) 919 (41°) 980 (10° x 41°)	
	Efficacy (lm / W)	36.6 (8°) 32.2 (14°) 32.2 (23°) 30.8 (41°) 33.1 (10° x 41°)	
	Lumen Maintenance‡	50,000 hours L70 @ 25° C 40,000 hours L70 @ 50° C 50,000 hours L50 @ 25° C 50,000 hours L50 @ 50° C	
Electrical	Input Voltage	100 – 240 VAC, auto-switching, 50 / 60 Hz	
	Power Consumption	30 W maximum at full output, steady state	
Control	Interface	Data Enabler Pro (DMX / Ethernet)	
	Control System	Philips full range of controllers, including Light System Manager, iPlayer 3, and ColorDial Pro, or third-party controllers	
Physical	Dimensions (Height x Width x Depth)	10.8 x 8.0 x 6.8 in (274 x 204 x 175 mm) Architectural 10.7 x 6.4 x 6.8 in (271 x 163 x 175 mm) Landscape	
	Weight	11 lb (5 kg) Architectural 7.4 lb (3.4 kg) Landscape	
	Housing	Die-cast aluminium, powder-coated finish	
	Lens	Tempered glass	
	Fixture Connections	6 ft (1.8 m) unified power / data cable with flying leads Architectural 6 in (152 mm) flying leads Landscape	
	Temperature Ranges	-40° – 122° F (-40° – 50° C) Operating -4° – 122° F (-20° – 50° C) Startup -40° – 176° F (-40° – 80° C) Storage	
	Vibration Resistance	ANSI C136.31 (Architectural only)	
	Humidity	0 – 95%, non-condensing	
	Fixture Run Lengths§	46 @ 100 VAC 55 @ 120 VAC 78 @ 220 VAC 78 @ 240 VAC	Example configuration: 20 A circuit, 20 ft (6.1 m) leader cable from Data Enabler Pro to the first junction box, and 2 ft (610 mm) jumper cables between fixtures
	Certification and Safety	Certification	UL / cUL, FCC Class A, CE, PSE, C-Tick, CQC, SAA
Environment		Dry / Damp / Wet Location, IP66	

\* Color temperatures conform to nominal CCTs as defined in ANSI Chromaticity Standard C78.377A.

† Lumen measurement complies with IES LM-79-08 testing procedures

‡ L70 = 70% lumen maintenance (when light output drops below 70% of initial output). L50 = 50% lumen maintenance (when light output drops below 50% of initial output). Ambient luminaire temperatures specified. Lumen maintenance calculations are based on lifetime prediction graphs supplied by LED source manufacturers. Calculations for white-light LED fixtures are based on measurements that comply with IES LM-80-08 testing procedures. Refer to [www.philipscolorkinetics.com/support/appnotes/lm-80-08.pdf](http://www.philipscolorkinetics.com/support/appnotes/lm-80-08.pdf) for more information.

§ These figures, provided as a guideline, are accurate for this configuration only. Changing the configuration can affect the fixture run lengths.

CHROMACORE<sup>®</sup> | OPTIBIN<sup>®</sup> | POWERCORE<sup>®</sup>  
CKTECHNOLOGY | CKTECHNOLOGY | CKTECHNOLOGY

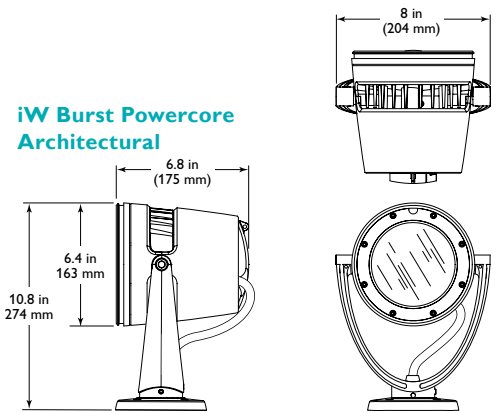

\* To calculate the number of fixtures your specific installation can support, download the Configuration Calculator from [www.philipscolorkinetics.com/support/install\\_tool/](http://www.philipscolorkinetics.com/support/install_tool/)

## iW Burst Powercore Landscape

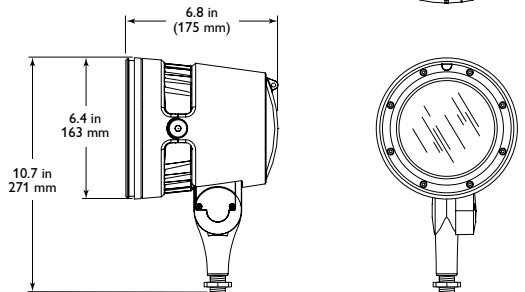

# iW Burst Compact Powercore Specifications

Due to continuous improvements and innovations, specifications may change without notice.

## iW Burst Compact Powercore Architectural

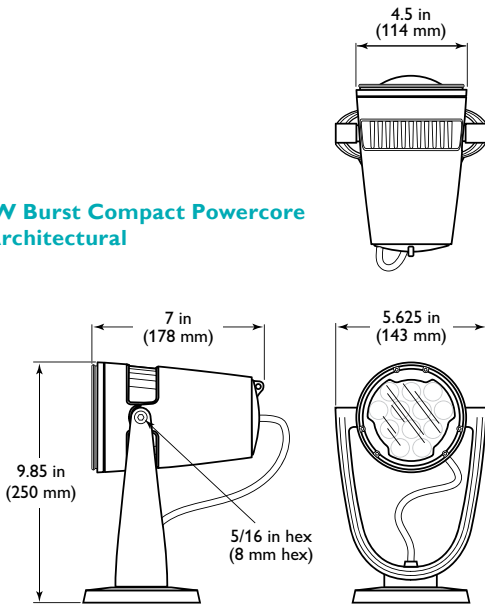

\* To calculate the number of fixtures your specific installation can support, download the Configuration Calculator from [www.philipscolorkinetics.com/support/install\\_tool/](http://www.philipscolorkinetics.com/support/install_tool/)

## iW Burst Compact Powercore Landscape

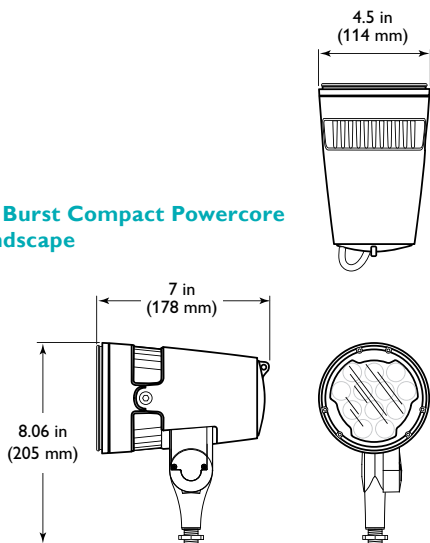

Item	Specification	Details
Output	Beam Angle	8° primary optic 14° / 23° / 41° spread lenses 10° x 41° asymmetric spread lens
	Color Temperature*	2700 K – 6500 K
	Lumens†	709 (8°) 622 (14°) 621 (23°) 609 (41°) 637 (10° x 41°)
	Efficacy (lm / W)	32.5 (8°) 28.5 (14°) 28.5 (23°) 27.9 (41°) 29.2 (10° x 41°)
	Lumen Maintenance‡	50,000 hours L70 @ 25° C 35,000 hours L70 @ 50° C 50,000 hours L50 @ 25° C 50,000 hours L50 @ 50° C
Electrical	Input Voltage	100 – 240 VAC, auto-switching, 50 / 60 Hz
	Power Consumption	15 W maximum at full output, steady state
Control	Interface	Data Enabler Pro (DMX / Ethernet)
	Control System	Philips full range of controllers, including Light System Manager, iPlayer 3, and ColorDial Pro, or third-party controllers
Physical	Dimensions (Height x Width x Depth)	9.85 x 4.5 x 7.0 in (250 x 114 x 178 mm) Architectural 8.06 x 4.5 x 7.0 in (205 x 114 x 178 mm) Landscape
	Weight	8.7 lb (3.9 kg) Architectural 4.4 lb (2.0 kg) Landscape
	Housing	Die-cast aluminium, powder-coated finish
	Lens	Tempered glass
	Fixture Connections	6 ft (1.8 m) unified power / data cable with flying leads Architectural 6 in (152 mm) flying leads Landscape
	Temperature Ranges	-40° – 122° F (-40° – 50° C) Operating -4° – 122° F (-20° – 50° C) Startup -40° – 176° F (-40° – 80° C) Storage
	Vibration Resistance	ANSI C136.31 (Architectural only)
	Humidity	0 – 95%, non-condensing
	Fixture Run Lengths§	77 @ 100 VAC 78 @ 120 VAC 78 @ 220 VAC 78 @ 240 VAC
Certification and Safety	Certification	UL / cUL, FCC Class A, CE, PSE, C-Tick, CQC, SAA
	Environment	Dry / Damp / Wet Location, IP66

\* Color temperatures conform to nominal CCTs as defined in ANSI Chromaticity Standard C78.377A.



† Lumen measurement complies with IES LM-79-08 testing procedures

‡ L70 = 70% lumen maintenance (when light output drops below 70% of initial output).

L50 = 50% lumen maintenance (when light output drops below 50% of initial output). Ambient luminaire temperatures specified. Lumen maintenance calculations are based on lifetime prediction graphs supplied by LED source manufacturers. Calculations for white-light LED fixtures are based on measurements that comply with IES LM-80-08 testing procedures. Refer to [www.philipscolorkinetics.com/support/appnotes/lm-80-08.pdf](http://www.philipscolorkinetics.com/support/appnotes/lm-80-08.pdf) for more information.

§ These figures, provided as a guideline, are accurate for this configuration only. Changing the configuration can affect the fixture run lengths.

CHROMACORE™ CK TECHNOLOGY | OPTIBIN™ CK TECHNOLOGY | POWERCORE™ CK TECHNOLOGY

# Fixtures

iW Burst Powercore fixtures are part of a complete system which includes fixtures and:

- One or more Data Enabler Pro devices
- Any Philips controller, including Light System Manager, iPlayer 3, and ColorDial Pro, or a third-party controller
- 4-conductor copper wire to connect IW Burst Powercore fixtures in series or in parallel. Standard 12 AWG (2.05 mm) stranded wire is recommended.

Item	Size	Housing Color	Item Number	Philips 12NC
iW Burst Powercore Landscape UL / cUL / CE	Standard	Gray	523-000064-00	910503702055
		Black	523-000064-03	910503702139
		White	523-000064-06	910503702142
	Compact	Gray	523-000067-00	910503702057
		Black	523-000067-03	910503702208
		White	523-000067-06	910503702211
iW Burst Powercore Architectural UL / cUL / CE	Standard	Gray	523-000064-01	910503702056
		Black	523-000064-04	910503702140
		White	523-000064-07	910503702143
	Compact	Gray	523-000067-01	910503702058
		Black	523-000067-04	910503702209
		White	523-000067-07	910503702212
iW Burst Powercore Architectural CQC	Standard	Gray	523-000064-02	910503702138
		Black	523-000064-05	910503702141
		White	523-000064-08	910503702144
	Compact	Gray	523-000067-02	910503702347
		Black	523-000067-05	910503702348
		White	523-000067-08	910503702349



Use Item Number when ordering in North America.

## Accessories

Item	Type	Size	Housing Color	Item Number	Philips 12NC
	Trim Ring	Standard	Gray	120-000103-00	910503701212
			Black	120-000103-06	910503701734
			White	120-000103-12	910503701737
	Trim Ring	Compact	Gray	120-000103-03	910503701420
			Black	120-000103-09	910503701823
			White	120-000103-15	910503701826
	45° Glare Shield	Standard	Gray	120-000103-01	910503701213
			Black	120-000103-07	910503701735
			White	120-000103-13	910503701738
	45° Glare Shield	Compact	Gray	120-000103-04	910503701421
			Black	120-000103-10	910503701824
			White	120-000103-16	910503701827
	Full Height Glare Shield	Standard	Gray	120-000103-02	910503701214
			Black	120-000103-08	910503701736
			White	120-000103-14	910503701739
	Full Height Glare Shield	Compact	Gray	120-000103-05	910503701422
			Black	120-000103-11	910503701825
			White	120-000103-17	910503701828
	Honeycomb Louver	Standard	Black	120-000104-00	910503701215
		Compact	Black	120-000104-01	910503701419
	Spread Lenses	14°	Standard	120-000080-00	910503700609
			Compact	120-000080-04	910503701415
		23°	Standard	120-000080-01	910503700610
			Compact	120-000080-05	910503701416
		41°	Standard	120-000080-02	910503700611
			Compact	120-000080-06	910503701417
		10° x 41° asymmetric	Standard	120-000080-03	910503700612
			Compact	120-000080-07	910503701418
Data Enabler Pro		3/4 in / 1/2 in NPT (US trade size conduit)		106-000004-00	910503701210
		PG21 / PG13 (metric size conduit)		106-000004-01	910503701211

\* You can attach either one Honeycomb Louver or one Spread Lens at a time.

Use Item Number when ordering in North America.

# Installation

iW Burst Powercore offers intelligent white light in a range of color temperatures for LED spotlighting, site lighting, and accent lighting with Powercore technology. Powercore, which integrates LED power and data management within the fixture, eases installation by eliminating the need for external power supplies.

## Owner / User Responsibilities

It is the responsibility of the contractor, installer, purchaser, owner, and user to install, maintain, and operate iW Burst Powercore fixtures in such a manner as to comply with all applicable codes, state and local laws, ordinances, and regulations. Consult with the appropriate electrical inspector to ensure compliance.

## Installing in Damp or Wet Locations

When installing in damp or wet locations, it is good practice to seal all fixtures and junction boxes with electronics-grade RTV silicone sealant to ensure that moisture cannot enter or accumulate in any wiring compartments, cables, or other electrical parts. You must use suitable outdoor-rated junction boxes when installing in wet or damp locations. Additionally, you must use gaskets, clamps, and other parts required for installation to comply with all applicable local and national codes

# Plan the Installation

1. Refer to the lighting design plan, architectural diagram, or other diagram that shows the physical layout of the installation to identify the locations of all switches, controllers, Data Enabler Pro devices, fixtures, and cables.

iW Burst Powercore fixtures can be installed in series or in parallel (wired to a common junction box).

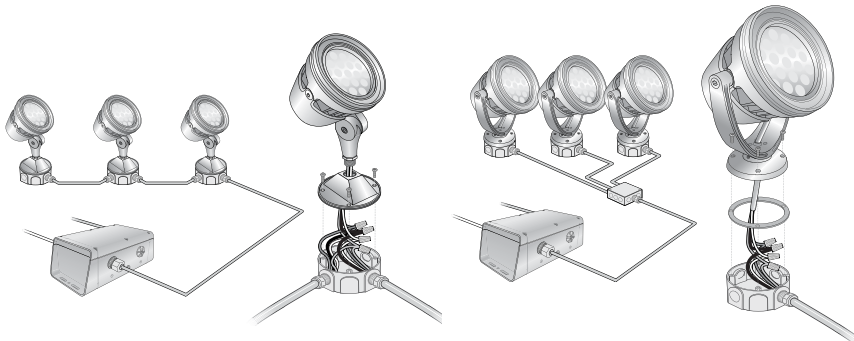

- iW Burst Powercore Architectural fixtures feature a canopy base for mounting to standard US junction boxes. Fixtures can be mounted directly to a surface or substrate by removing the nylon cable clamp and disengaging the 6 ft (1.8 m) integrated power / data cable from the canopy base.
- iW Burst Powercore Landscape fixtures feature a 1/2 in NPT threaded post for mounting to standard junction boxes and third-party mounting accessories such as stanchion mounts, posts, and stakes.

The maximum number of fixtures each Data Enabler Pro can support depends on specific configuration details such as length of leader and jumper cables, wire gauge, fixture spacing, circuit size, line voltage, and method of connection (in series or in parallel). As an example, the tables to the left list the maximum number of iW Burst Powercore Landscape and iW Burst Compact Powercore Landscape fixtures each Data Enabler Pro can support at various voltages, assuming a 20 A circuit, a 20 ft (6.1 m) leader cable from Data Enabler Pro to the first junction box, and 2 ft (610 mm) jumper cables between fixtures. Keep in mind that these figures, provided as a guideline, are accurate for the specified configuration only. Changing the configuration can affect the fixture run lengths.

\* iW Burst Powercore and iW Burst Compact Powercore installation and configuration details are identical except where indicated.

\* Refer to the iW Burst Powercore Installation Instructions for specific warning and caution statements.

\* To streamline the configuration of complex installations, record the serial number (DMX) or IP address (Ethernet) and location of each Data Enabler Pro.

## Maximum fixture run lengths

iW Burst Powercore
46 @ 100 VAC
55 @ 120 VAC
78 @ 220 VAC
78 @ 240 VAC

iW Burst Compact Powercore
77 @ 100 VAC
78 @ 120 VAC
78 @ 220 VAC
78 @ 240 VAC

assuming a 20 A circuit, 20 ft (6.1 m) leader cable from Data Enabler Pro to the first junction box, and 2 ft (610 mm) jumper cables between fixtures

\* For more information, and for help calculating the number of fixtures your specific installation can support, download the Configuration Calculator from [www.philipscolorkinetics.com/support/install\\_tool/](http://www.philipscolorkinetics.com/support/install_tool/), or consult Application Engineering Services at [support@colorkinetics.com](mailto:support@colorkinetics.com).



In addition to maximum fixture run lengths determined by the electrical configuration, each Data Enabler Pro imposes maximum run lengths based on data integrity. To ensure data integrity, maximum individual run length should not exceed 175 feet (53.3 m), and the total cable length per Data Enabler Pro should not exceed 400 feet (122 m).

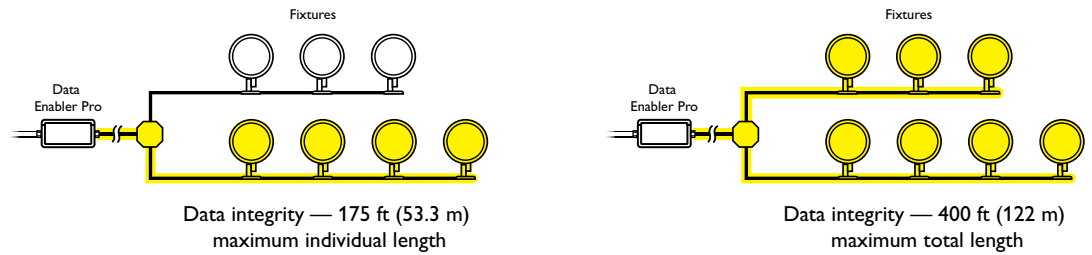

For installations in which you want to manually adjust the brightness and color temperature of all connected iW Burst Powercore fixtures in unison, use ColorDial Pro. For installations in which you want to dynamically control the brightness and color temperature of individual fixtures, use a controller such as iPlayer 3 or Light System Manager. Refer to “Controlling iW Burst Powercore Fixtures” below for details.

## Start the Installation

✳ For complete instructions on how to wire the Data Enabler Pro, refer to the Data Enabler Pro Product Guide.

1. Install all Data Enabler Pro devices, including any interfaces with controllers. Data Enabler Pro devices and external controllers send power and control signals to the fixtures over a single fixture cable. Additional cabling is required to connect fixtures together in parallel or in series.
2. Verify that all additional supporting equipment (switches, controllers) is in place.
3. Ensure that all additional parts and tools are available, including:

### iW Burst Powercore Architectural Installations

- The provided stainless steel screws for outdoor installations
- The provided junction box gasket for outdoor installations
- Unless surface-mounting, one 4 in (102 mm) round US electrical junction box per fixture, rated for your application, with 3.5 in (89 mm) center-to-center screw holes for attaching the fixture’s base. (Refer to the manufacturer’s literature for additional items required for mounting or sealing.)
- A 6 mm hex wrench for fixture tilting and locking
- A 1/8 in hex wrench for fixture swiveling and locking

### iW Burst Powercore Landscape Installations

- The provided locking nut
- One electrical junction box or mounting accessory per fixture, rated for your application. (Refer to the junction box or accessory manufacturer’s literature for specific information on mounting or sealing.)
- A 6 mm hex wrench for fixture tilting and locking
- A 33 mm wrench for locking fixtures in place

### All Installations

- A sufficient length 4-conductor wire. We recommend 12 AWG (2.05 mm) stranded copper wire.
- Conduit as required

- Electronics-grade room temperature vulcanizing (RTV) silicone sealant as required
- A 5/32 in hex wrench for installing accessories, or a 3 mm hex wrench for installing iW Burst Compact Powercore accessories

## Unpack and Prepare Fixtures

1. Carefully inspect the box containing iW Burst Powercore and the contents for any damage that may have occurred in transit.

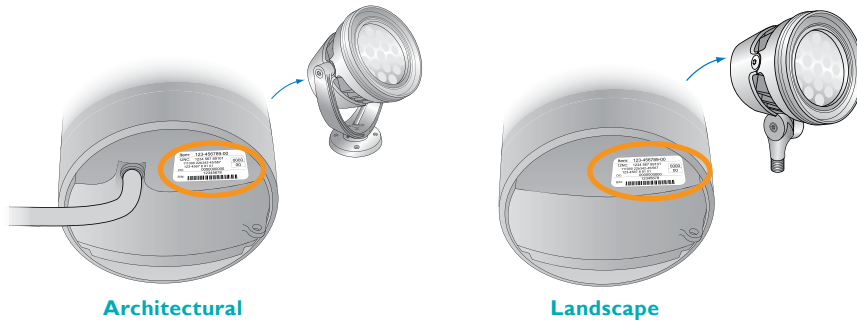

2. Each iW Burst Powercore fixture comes pre-programmed with a unique serial number. If you plan to control fixtures independently, record the serial numbers in a layout grid (typically a spreadsheet or list) for easy reference and light addressing.
3. Assign each fixture to a position in the lighting design plan.
4. To streamline installation and aid in light show programming when using dynamic effects, you can affix a weatherproof label identifying the order or placement in the installation to an inconspicuous location on each light fixture's housing.

## Connect and Mount iW Burst Powercore Architectural Fixtures

iW Burst Powercore Architectural fixtures can be mounted to standard US junction boxes, or they can be mounted to a flat surface or substrate.

Make sure the power is OFF before mounting and connecting iW Burst Powercore fixtures.

### Connecting iW Burst Powercore Architectural Fixtures to Junction Boxes

1. Mount junction boxes in accordance with the lighting design plan. Each fixture is designed for mounting in a 4 in (102 mm) round US electrical junction box, rated for your application, with 3.5 in (89 mm) center-to-center screw holes for attaching the fixture's base.

Architectural fixtures are supplied with a grounding wire attached to the fixture's base (canopy). The canopy ground wire can be attached to a grounding point in the junction box, or connected with the ground in the fixture cable

Wiring between junction boxes must comply with local codes.

2. If installing fixtures in a series, pull copper wire between the junction boxes.

If installing fixtures in parallel, pull copper wire from a Data Enabler Pro to a common junction box, and from the common junction box to each fixture's junction box.

### Included in the box

#### iW Burst Powercore Architectural

iW Burst Powercore Architectural fixture

(4) 10-24 stainless steel screws for outdoor installation

Junction box gasket

Installation Instructions



#### iW Burst Powercore Landscape

iW Burst Powercore Landscape fixture

Locking nut

Installation Instructions

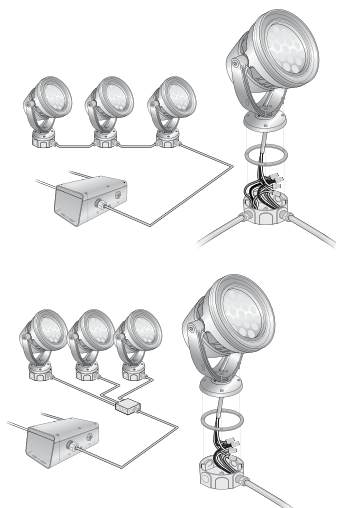
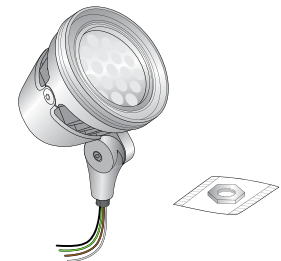

We recommend the use of 12 AWG (2.05 mm), stranded 4-conductor copper wire. With the recommended wiring, the maximum cable run from a Data Enabler Pro device to any individual iV Burst Powercore fixture is 175 feet (53 m). When installing in parallel, the total cable length cannot exceed 400 feet (122 m).

### Leader Cable connector dimensions

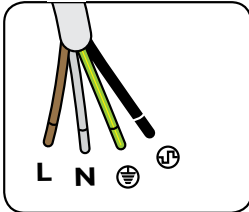
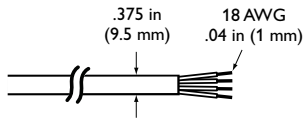

3. Trim the cable from the fixture to fit in the junction box, leaving enough cable to make wiring connections.
4. Use wire nuts to connect line, neutral, ground, and data. If installing in a damp or wet location, use the included junction box gasket.

Attach the canopy ground wire to a grounding point in the junction box, or combine it with the fixture cable ground with a wire nut.

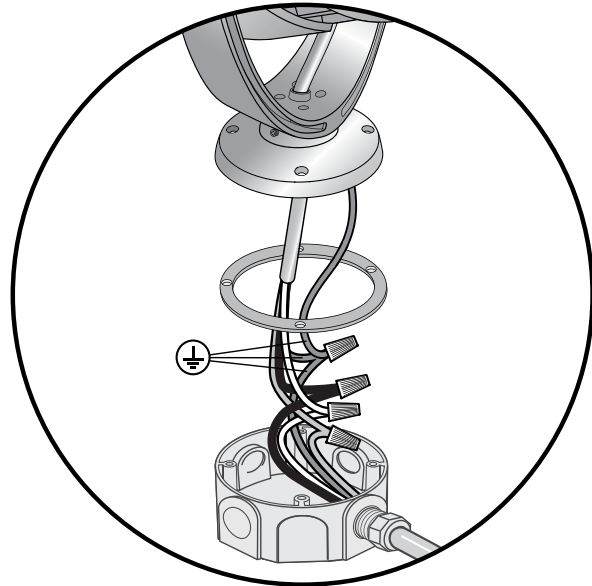

5. Tuck wire connections into the junction box.
6. Screw the fixture's canopy base into the junction box using the four included 10-24 stainless steel screws. If installing in a damp or wet location, seal all junction boxes with elect-grade RTV silicone sealant. Use gaskets, clamps, and other parts and fittings required to comply with local outdoor wiring codes.

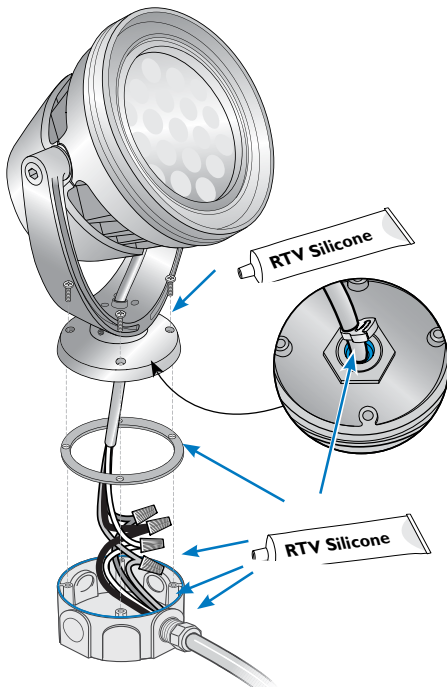

## Surface-Mounting iW Burst Powercore Architectural Fixtures

### 1. Prepare iW Burst Powercore Architectural fixtures for surface-mounting:

- Remove the nylon cable clamp from the fixture's leader cable where it exits the underside of the canopy base.

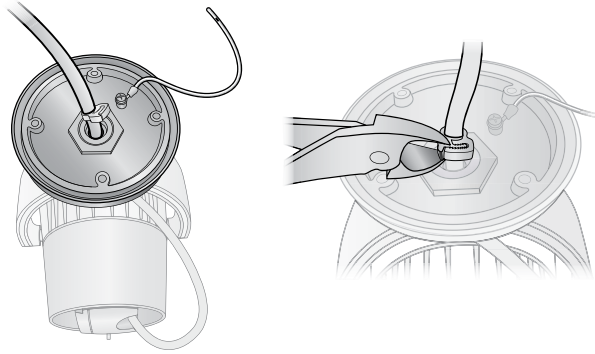

- Disengage the leader cable from the fixture's canopy base.

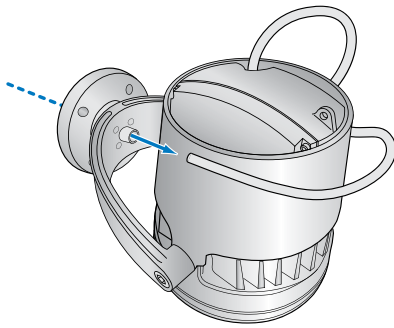

- Mount junction boxes in accordance with the lighting design plan.
- Position each iW Burst Powercore Architectural fixture in its designated mounting location. Make sure the mounting surface is flat, suitable for the mounting hardware, and clear of debris and other obstructions.
- Use four suitable mounting screws to secure each iW Burst Powercore Architectural fixture to the mounting location.

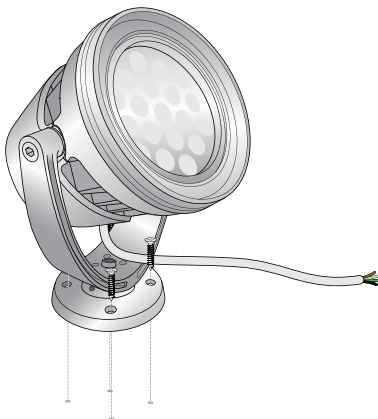

### Leader Cable connector dimensions

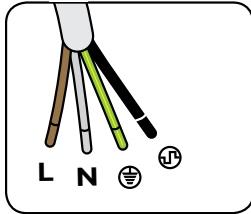
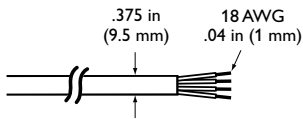

5. If installing fixtures in a series, pull copper wire between the junction boxes.

If installing fixtures in parallel, pull copper wire from a Data Enabler Pro to a common junction box.

We recommend the use of 12 AWG (2.05 mm), stranded 4-conductor copper wire. With the recommended wiring, the maximum cable run from a Data Enabler Pro device to any individual iW Burst Powercore fixture is 175 feet (53 m). When installing in parallel, the total cable length cannot exceed 400 feet (122 m).

6. Use wire nuts to connect line, neutral, ground, and data. If installing in a damp or wet location, use the included junction box gasket.

7. Tuck wire connections into the junction box.

8. Secure all junction box covers. If installing in a damp or wet location, seal all junction boxes with electronics-grade RTV silicone sealant. Use gaskets, clamps, and other parts and fittings required to comply with local outdoor wiring codes.

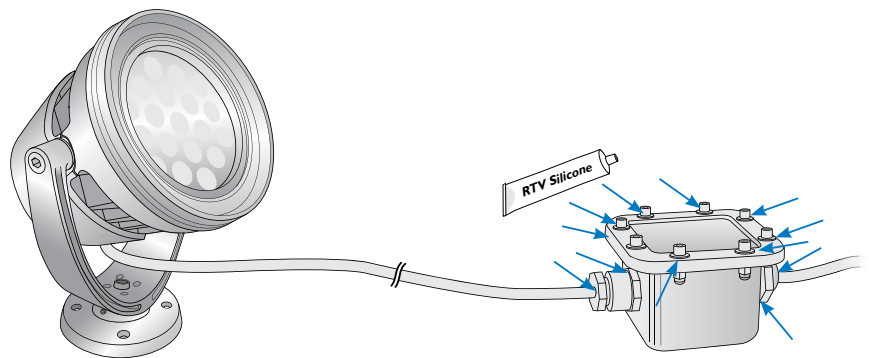

## Connect and Mount iW Burst Powercore Landscape Fixtures

iW Burst Powercore Landscape fixtures feature a 1/2 in NPT threaded post for installing to standard junction boxes, stanchion mounts, posts, stakes, and other landscape mounting accessories.

Make sure the power is OFF before mounting and connecting iW Burst Powercore fixtures.

1. Mount junction boxes and any landscape mounting accessories in accordance with the lighting design plan.

2. If installing fixtures in a series, pull copper wire between the junction boxes, and from the junction boxes to the fixtures as needed.

If installing fixtures in parallel, pull copper wire from a Data Enabler Pro to a common junction box, and from the common junction box to the fixtures.

We recommend the use of 12 AWG (2.05 mm), stranded 4-conductor copper wire. With the recommended wiring, the maximum cable run from a Data Enabler Pro device to any individual iW Burst Powercore fixture is 175 feet (53 m). When installing in parallel, the total cable length cannot exceed 400 feet (122 m).

3. Thread the locking nut onto the iW Burst Powercore Landscape threaded post.

4. Use wire nuts to connect line, neutral, ground, and data.

5. Tuck wire connections into the junction box or mounting accessory.

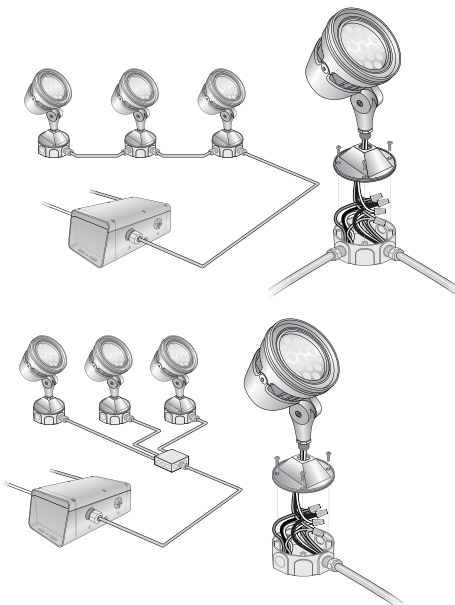

6. Using a 33 mm wrench, torque the locking nut to 25 ft-lb (33.9 Nm). Do not overtighten.

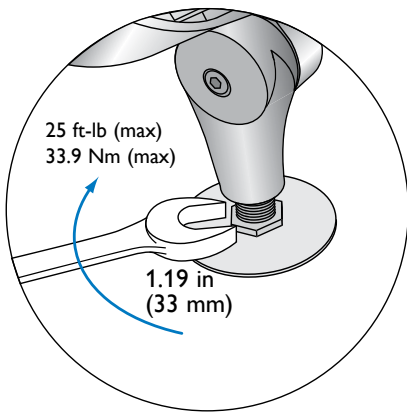
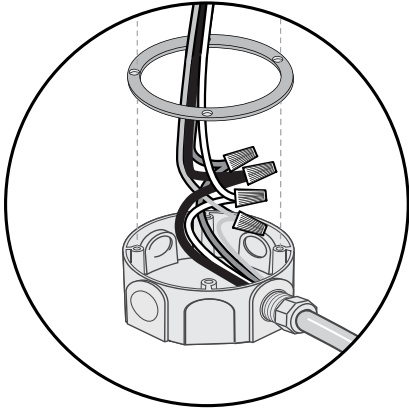

7. If installing in a damp or wet location, seal all junction boxes and mounting accessories with electronics-grade RTV silicone sealant. Use gaskets, clamps, and other parts and fittings required to comply with local outdoor wiring codes.

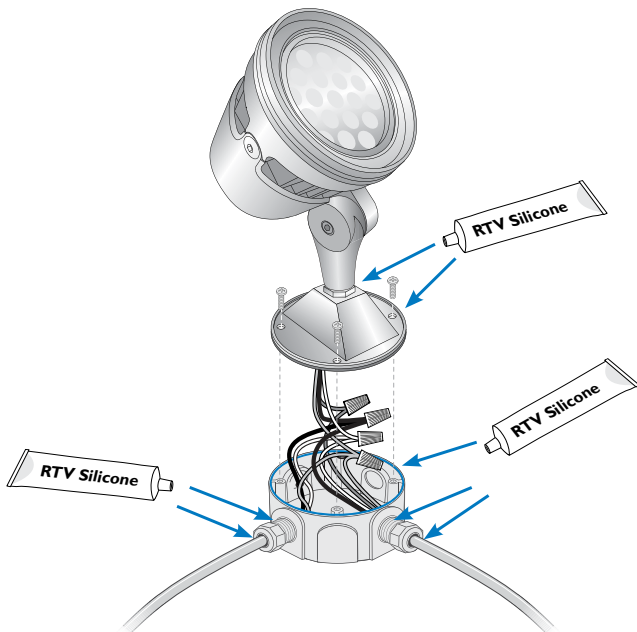

## Connect Fixture Cable to Power

Once you've made all fixture and junction box connections, connect the lead cable to the fixture cable 4-wire PC terminal connector block inside the Data Enabler Pro Housing.

\* Refer to the *Data Enabler Pro Product Guide* for comprehensive installation and configuration instructions. You can view or download the guide from [www.philipscolorkinetics.com/ls/pds/dataenablerpro](http://www.philipscolorkinetics.com/ls/pds/dataenablerpro)

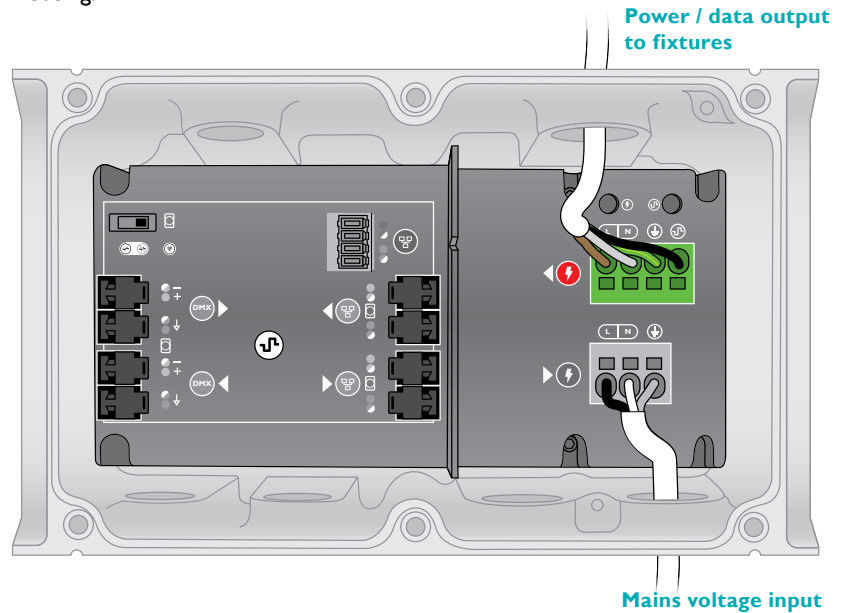
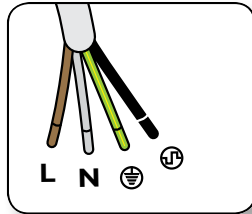

## Attach Safety Cable (Optional)

When installing iW Burst Powercore fixtures to a wall or overhead, use a safety cable to tether it to a secure anchor point. When dictated by local or state code or advised by a structural engineer, attach a safety cable to the iW Burst Powercore fixture housing and tether it to a secure anchor point.

### Safety cable minimum requirements

Material	304 or 316 Stainless Steel
Size	5/32 in (4 mm) nominal diameter Minimum break load must be greater than 2,400 lb (1089 kg)

1. Thread a safety cable through the fixture housing as shown.

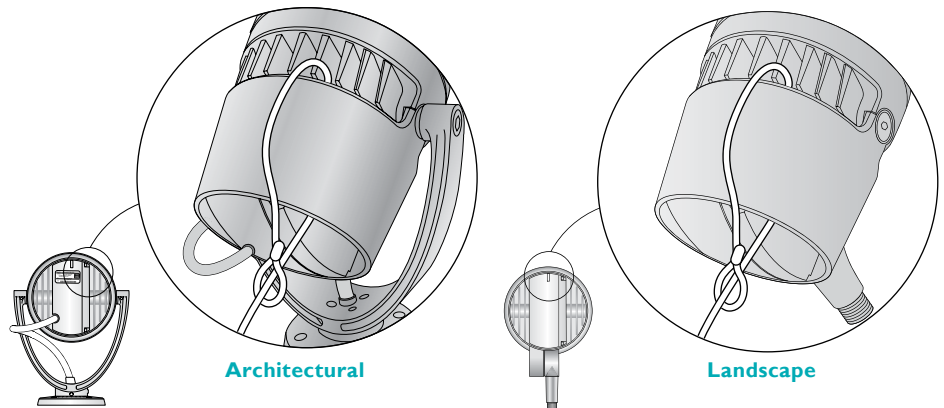

2. Attach the safety cable to the mounting surface using a method that follows the code or engineer's requirements.



## Attach Accessories (Optional)

Honeycomb Louvers and exchangeable iW Burst Powercore spread lenses of 14°, 23°, 41°, and an asymmetric 10° x 41° support a variety of photometric distributions for a multitude of applications.

You attach Honeycomb Louvers and Spread Lenses with the Trim Ring, 45° Glare Shield, or Full Height Glare Shield, available separately. You can attach either one Honeycomb Louver or one Spread Lens at a time.

1. Unpack and confirm the contents of the box. Each accessory is shipped one per box. Spread Lenses include an attached rubber gasket. The Trim Ring, 45° Glare Shield, and Full Height Glare Shield include an attached locking screw.
2. Clean the face of the iW Burst Powercore housing, including glass surfaces, using a mild, non-abrasive cleaner. Ensure that all surfaces are dry. If using a spread lens, also clean and dry both sides of the spread lens.
3. If using a spread lens, remove the protective film from the side of the lens on which the beam angle is printed.

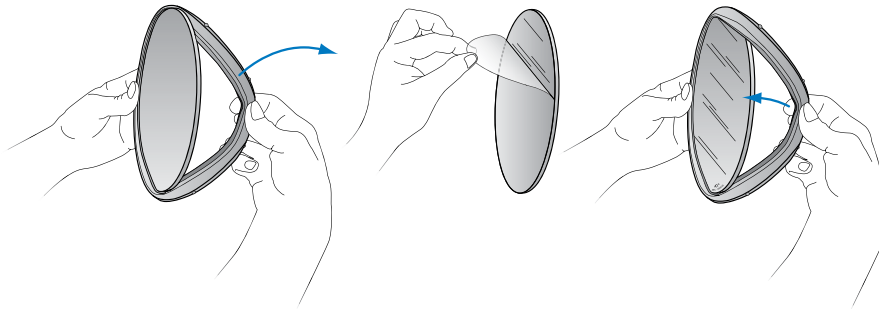
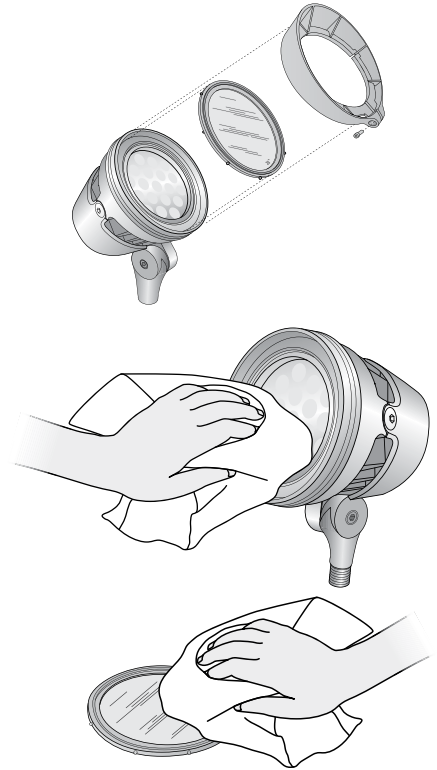

4. Position the honeycomb louver or spread lens:

- If using the honeycomb louver, insert the tab on the honeycomb louver into the notch on the face of the iW Burst Powercore fixture housing.

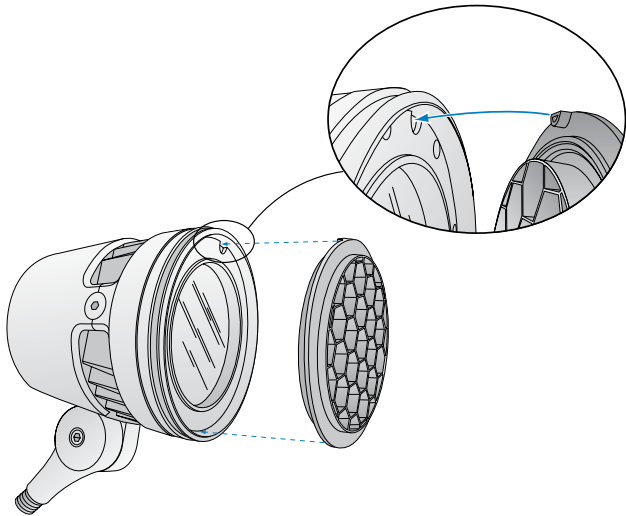





⚙️ Rotating the asymmetric 10° x 41° spread lens changes its effect on the fixture's light output. You may want to rough-in the spread lens position, fine-tune it when aiming and locking the fixture, then lock down the trim ring or glare shield once the lens is positioned to give the desired results.

- If using a spread lens, make sure that the beam-angle designation on the edge of the lens is face up. Handle the spread lens by the gasket, making sure not to touch or soil either surface of the spread lens. Rest the lens against the face of the iW Burst Powercore housing. Make sure that there is no moisture between the spread lens and the glass lens, as any moisture will compromise the effectiveness of the spread lens.

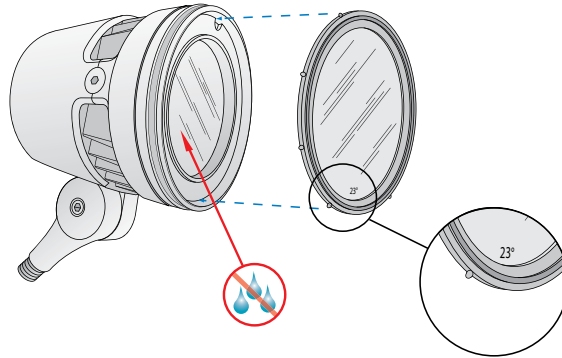

5. If necessary, use a 5/32 in hex wrench to remove the locking screw from the trim ring or glare shield.
6. Grab the trim ring or glare shield with both hands, flex it gently open, and clip it to the front rim of the fixture housing.

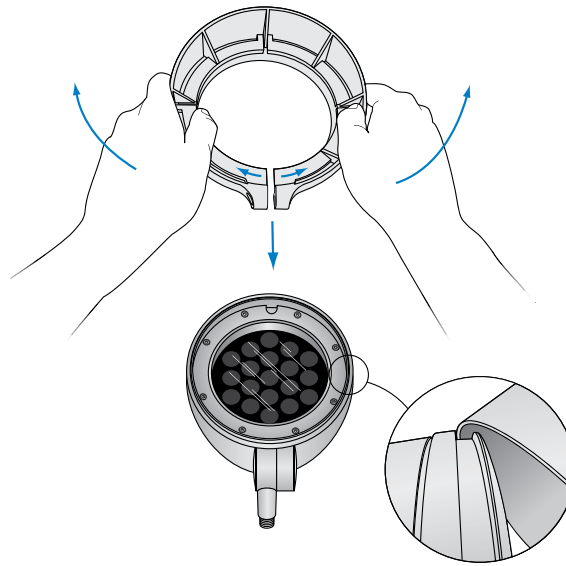

7. Insert the locking screw into the opening on the trim ring or glare shield. Use a 5/32 in hex wrench and torque to 6 in-lbs (.6 Nm). For IW Burst Compact Powercore, use a 3 mm hex wrench.

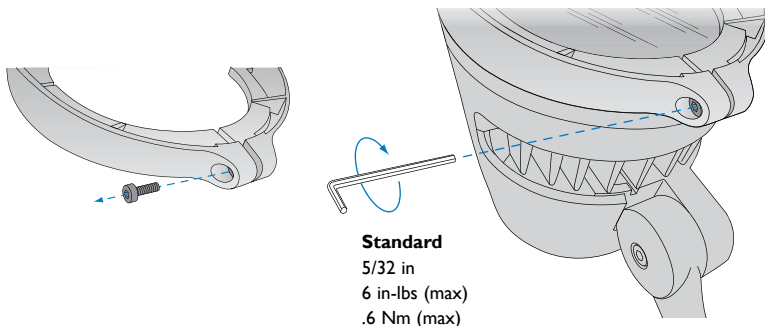

**Standard**  
5/32 in  
6 in-lbs (max)  
.6 Nm (max)

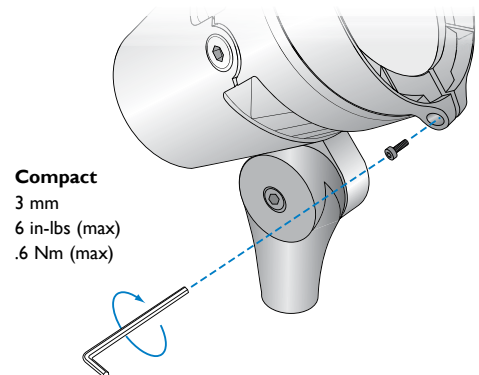

**Compact**  
3 mm  
6 in-lbs (max)  
.6 Nm (max)

# Controlling iW Burst Powercore Fixtures

Philips Color Kinetics offers a number of control options for all iW Burst Powercore fixtures, from simple to complex.

## Displaying Fixed Light Output

For installations in which you want to manually adjust the brightness and color temperature of all fixtures in unison, use ColorDial Pro in iW Mode. With ColorDial Pro, no fixture addressing or configuration is necessary.

ColorDial Pro is a Power-Over-Ethernet (PoE) device that requires a PoE switch, or a conventional Ethernet switch with a PoE injector. Refer to the *ColorDial Pro Installation Instructions* and the *ColorDial Pro User Guide* for details on how to install and use ColorDial Pro with iW Burst Powercore fixtures.

## Displaying Dynamic Light Output

For dynamic installations in which you want to display different light output on iW Burst Powercore fixtures simultaneously, you must use an RGB-based DMX or Ethernet controller such as iPlayer 3 or Light System Manager. To support dynamic effects that automatically modify brightness and color temperature on individual fixtures, you must address and configure iW Burst Powercore fixtures as you would any color-changing (RGB) fixture.

iW Burst Powercore fixtures use DMX addresses to communicate with controllers. The number of DMX addresses each iW Burst Powercore fixture requires depends on the fixture's configuration.

# Addressing iW Burst Powercore Fixtures

Make sure the power is ON before addressing and configuring fixtures.

You address and configure iW Burst Powercore fixtures using QuickPlay Pro addressing and configuration software. Fixtures are identified within QuickPlay Pro by serial number, so you will need the layout grid that you created when you recorded the serial numbers of your fixtures during installation planning.

- In Ethernet installations, you can address and configure your fixtures using QuickPlay Pro with a computer connected to your lighting installation's network. QuickPlay Pro can automatically discover all of your fixtures, controllers, and Data Enabler Pro devices for quick configuration.
- In DMX installations, you can address and configure your fixtures using QuickPlay Pro with iPlayer 3 or SmartJack Pro. You can manually enter fixture serial numbers, or you can import a spreadsheet listing each fixture's serial number and starting DMX address.

iW Burst Powercore fixtures operate in 8-bit mode by default. You can configure fixtures to operate in 16-bit mode, which increases resolution for smoother dimming and more precise control. In 8-bit mode, fixtures use one DMX address per LED channel. In 16-bit mode, fixtures use two DMX addresses per LED channel. The first DMX address corresponds to the "coarse" data for that channel, and the second corresponds to the "fine" data. By using double the number of DMX addresses, 16-bit mode increases fixture resolution from 256 dimming steps to 65,536 (256 x 256) dimming steps.

You can address and configure iW Burst Powercore fixtures in much the same way as you would address any RGB fixture. The red channel corresponds to the warm LEDs, the green channel corresponds to the cool LEDs, and the blue channel is not used.

Note that although the blue DMX channel is not used, it is *assigned*, so that each iW Burst Powercore fixture uses three DMX sequential addresses (or a multiple of three addresses).

## LED Channels

RGB	iW Burst Powercore
Red	Warm
Green	Cool
Blue	Unused

 You can download QuickPlay Pro from [www.philipscolorkinetics.com/support/addressing/](http://www.philipscolorkinetics.com/support/addressing/)

\* You can download QuickPlay Pro from [www.philipscolorkinetics.com/support/addressing](http://www.philipscolorkinetics.com/support/addressing).

\* You will need the layout grid that you created when you recorded the serial numbers of the light fixtures in your installation.

\* Do not look directly into the fixture when aiming and locking.

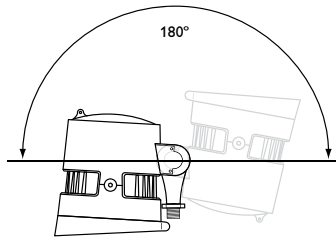

iW Burst Powercore fixtures come factory-addressed with a starting DMX address of 1. For lighting designs where fixtures work in unison, all fixtures can be assigned the same starting DMX address. Changes to the default starting DMX addresses are not necessary, but if lights were previously readdressed for use in other installations, you must reset them. For light show designs that show different light output on different fixtures simultaneously, you must assign unique DMX addresses to your fixtures and sort them in a useful order.

The following table shows the DMX channel assignments for 8-bit and 16-bit iW Burst Powercore configurations, assuming a starting DMX address of 1.

#### DMX Channel Assignments: Two-Channel Mode

8-bit Mode	1		2		3	
	Warm		Cool		Unused	
16-Bit Mode	1	2	3	4	5	6
	Warm	Warm	Cool	Cool	Unused	Unused

## Aim and Lock Fixtures

Make sure power is ON before aiming fixtures.

iW Burst Powercore fixtures can tilt through a full 180°. iW Burst Powercore Architectural fixtures can also rotate through a full 360° for precise aiming. Locking nuts use standard hex wrenches to secure fixtures firmly in position.

### Aiming and Locking iW Burst Powercore Landscape Fixtures

1. Using a 6 mm hex wrench, loosen the locking nut on the side of the fixture base.
2. Aim the fixture by tilting the beam as desired.
3. When the fixture is aimed as desired, re-tighten the locking nut to secure the fixture in place. Torque to 25 ft-lbs (33.9 Nm). Do not over-tighten.

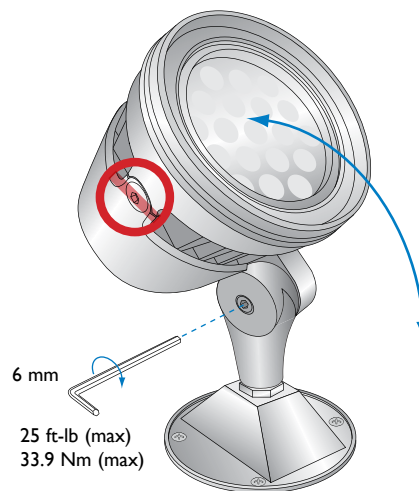

## Aiming and Locking iW Burst Powercore Architectural Fixtures

### 1. To tilt the beam:

- Loosen the locking nuts on either side of the fixture yoke using a 6 mm hex wrench.
- Tilt the beam as desired.

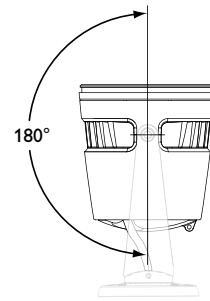
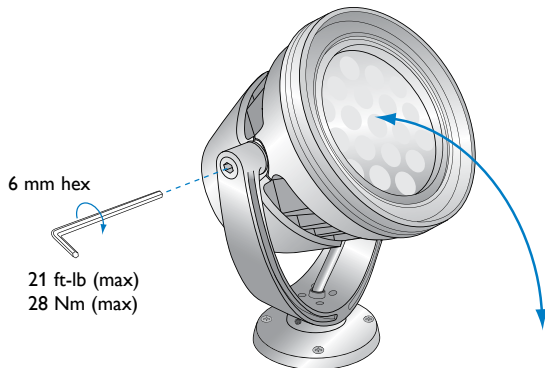

- Re-tighten the locking nuts to secure the fixture in place. Torque to 21 ft-lbs (28 Nm). Do not over-tighten.

### 2. To rotate the fixture:

- Loosen the locking nuts on either side of the fixture yoke's base using a 1/8 in or 3 mm hex wrench.
- Rotate the fixture as desired.

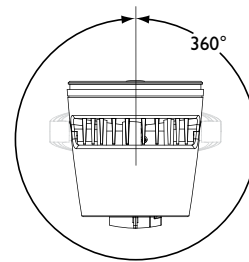
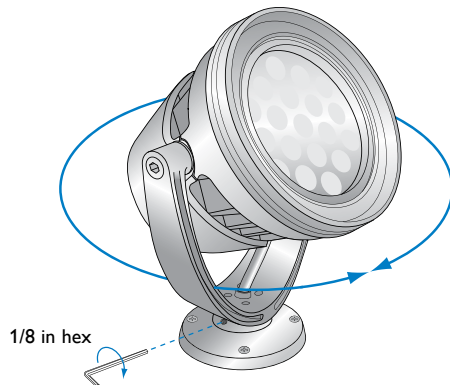

- Re-tighten the locking nuts to secure the fixture in place.



Philips Color Kinetics  
3 Burlington Woods Drive  
Burlington, Massachusetts 01803 USA  
Tel 888.385.5742  
Tel 617.423.9999  
Fax 617.423.9998  
www.philipscolorkinetics.com  
@ColorKinetics

Copyright © 2011 – 2014 Philips Solid-State Lighting Solutions, Inc. All rights reserved. Chromacore, Chromasic, CK, the CK logo, Color Kinetics, the Color Kinetics logo, ColorBlast, ColorBlaze, ColorBurst, ColorGraze, ColorPlay, ColorReach, iW Reach, eW Reach, eW Fuse, DillMand, EssentialWhite, eW, iColor, iColor Cove, IntelliWhite, iW, iPlayer, Optibin, and Powercore are either registered trademarks or trademarks of Philips Solid-State Lighting Solutions, Inc. in the United States and / or other countries. All other brand or product names are trademarks or registered trademarks of their respective owners. Due to continuous improvements and innovations, specifications may change without notice.

DAS-000083-00 R04 10-14