

DMXStreamer



GENERAL INFORMATION

The DMXStreamer represents the state of the art for recording and playing back shows of up to 512 channels. It takes the DMX input from your lighting board and records every nuance of it, in real time! Then a highly flexible scheduler lets you decide what to play back when, or with optional Remote you can manually start and stop a show at will.

APPLICATIONS

- ARCHITECTURAL:
- RESTAURANT
- RETAIL STORE
- MUSEUM/CULTURAL CENTER
- THEME PARK
- TRADE SHOW

FEATURES

- RS232 Serial Port for configuration and integration with other control systems
- Works seamlessly (via RS232) with Enttec DMXPlaybackRemote for triggering shows
- LCD display provides status information on what current show is and feedback from button selections
- Menu, Scroll and Enter membrane buttons.
- Real-time recording of 1 output from a DMX console for minutes, hours or days
- After recording streams, remove the console, leaving DMXStreamer as a standalone
- Shows (DMX streams) are played back at user-scheduled times or ad hoc.

- Schedule events can be daily, weekly, monthly, seasonal, annual, and/or based on astronomical clock.
- Special "Power Up" look available for striking lamps or other special cases.
- Streamer Utilities software included to facilitate configuring, starting and stopping recording of shows, playlist editing, show backup, firmware updates, etc.

ACCESSORIES

- DMXPlayback Remote (not included)
- Rack Mounting Ears 1U high (not included)
- Rack Mounting slot for 2 units which requires 2U height (not included)
- 3-pin to 5-pin Adapters (not included)
- USB to RS232 Smart Adapter (not included)

ORDERING INFORMATION

Part Number	Description
#70015	DMX Streamer

OPTIONS

PartNumber	Description
#70029	3-pin to 5-pin Adapters
#70006	2U 19" Rack Mount Kit
#70018	1U 19" Rack Mount Kit
#70027	DMXPlayback Remote
#70013	USB to RS232 adapter

SPARE PARTS

Part Number	Description
#79104	Universal Power Supply

GENERAL SPECIFICATIONS

Power Requirements	110v-240v AC
Weight	1.65 lbs / 0.75 kg
Shipped Weight	3.19 lbs / 1.45 kg

Supplied by:



Melbourne
03 9701 2500

Sydney
02 9737 8988

info@lightmoves.com.au

www.lightmoves.com.au

Width:	7.53" / 191mm
Height	1.75" / 44.45mm
Depth	4.14" / 105mm
Rack	1RU high x ½ RU wide
Operating Environment	0°-50°C in non-condensing environment

FUNCTIONAL SPECIFICATIONS

- RS232 port allows interconnection with ENTTEC DMXPlayback Remote or with Streamer Utilities, a Windows-based program to more easily configure device from a PC.
- DMX input port (for recording)
- DMX output port (for playback) also works as throughput when a show isn't playing
- DMX input signal loss can trigger a show
- Control up to 512 channels
- Record up to 26 shows
- Shows can be given text names
- Shows may be used repeatedly in Playlists and scheduled for multiple replays.
- Basic unit has 8MB of non-volatile memory
- Recording time allowable in each memory configuration will vary according to number of channels being streamed. Examples in table below are for the inbuilt 8MB of memory, with no compression at all.

Channels	Refresh Rate	Recording Time
16	10Hz	14:33:49
16	40Hz	03:38:27
96	25Hz	00:58:18
512	10Hz	00:27:18
512	40Hz	00:06:50

Most shows will compress somewhat, extending record time further.

- Recording and playing back can be initiated from menu using 3 buttons, or with use of Playback Remote or other RS232-based instructions See Enttec RS232 Protocol for details
- External power supply for 9-12V DC or use AC power input on 2.1mm DC jack
- Internal battery-backed real time clock
- CE, FCC certified

Technical Illustration with Dimensions

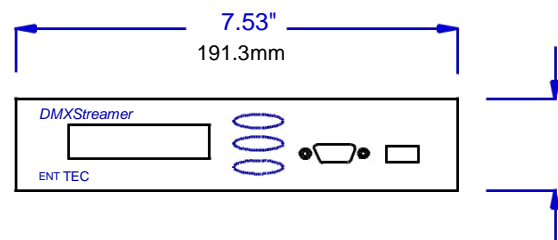

Wiring Diagrams (Riser)

DMXStreamer capturing DMX Input

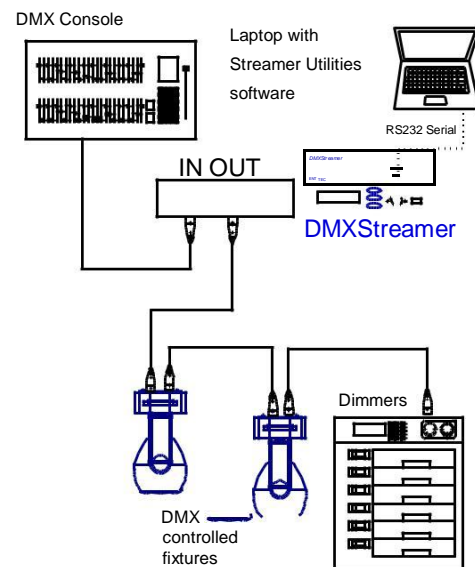

For additional Risers see Plates 70015-1 through 70015-4