



AN OSRAM BUSINESS

INSTRUCTION MANUAL



STORMY STORMY CC

The latest LED technology meets the charm of a classic strobe



Supplied by:

lightmoves

Melbourne
03 9701 2500

info@lightmoves.com.au

Sydney
02 9737 8988

www.lightmoves.com.au

STORMY C71090
STORMY CC C71091

www.claypaky.it



AN OSRAM BUSINESS

PRELIMINARY



STORMY STORMY CC

The latest LED technology meets the charm of a classic strobe

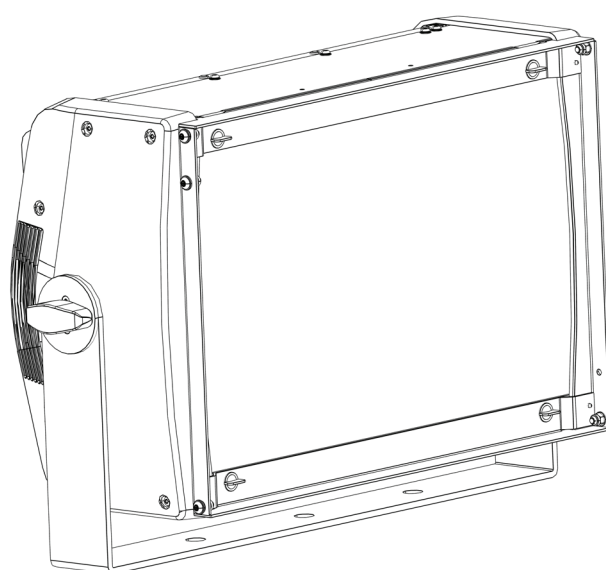

Congratulations on choosing a Clay Paky product!

We thank you for your choice. Please note that this product and all the others in the rich Clay Paky range, has been designed and manufactured with total quality to ensure excellent performance and best meet your expectations and requirements.



Carefully read this instruction manual and keep in its entirety and keep it safe for future reference.

It is essential to know the information supplied in this manual in order to ensure that the fitting is installed, used and serviced correctly and safely.



CLAY PAKY S.p.A. disclaims all liability for damage to the fitting or to the other property or persons deriving from installation, use and maintenance that have not been carried out in conformity with this instructions manual, which must always accompany the fitting.

CLAY PAKY S.p.A. reserves the right to modify the characteristics stated in this instructions manual at any time and channel list without prior notice.



AN OSRAM BUSINESS



STORMY STORMY CC

The latest LED technology meets the charm of a classic strobe

CONTENTS

Pag.

1. Safety Information	4
1. Informazioni sulla sicurezza	5
1. Informations sur la sécurité	6
1. Informationen zur sicherheit	7
1. Información sobre la seguridad	8
2. Unpacking And Preparation	9
3. Installation And Start-Up	11
4. Control Panel	12
5. Menu Setting	14
5.1 Set Up Menu	15
5.2 Options Menu	15
5.3 Information Menu	16
5.4 Manual Control Menu	17
5.5 Advanced Menu	17
6. Maintenance	18
7. Accessories	20
8. Technical Data	21
8.1/A Technical Data Stormy	21
8.1/B Technical Data Stormy CC	21
9. Channels	23
9.1/A Channel List Stormy	23
9.2/A Channel Function Stormy	23
9.1/B Channel List Stormy CC	24
9.2/B Channel Function Stormy CC	24
9.3 Duration Channels Details	29
9.4 Rete Channels Details	30
10. DURATION time - RATE time (PERIOD) relation	32

1. SAFETY INFORMATION



$t_a < 40\text{ }^\circ\text{C}$

IP20



$t_c \leq 100\text{ }^\circ\text{C}$



• Installation

Make sure all parts for fixing the projector are in a good state of repair. Make sure the point of anchorage is stable before positioning the projector. The safety chain must be properly hooked onto the fitting and secured to the framework, so that, if the primary support system fails, the fitting falls as little as possible. If the safety chain gets used, it needs to be replaced with a genuine spare.

• Minimum distance of illuminated objects

The projector needs to be positioned so that the objects hit by the beam of light are at least 0.2 metres (8") from the lens of the projector.

• Minimum distance from flammable materials

The projector must be positioned so that any flammable materials are at least 0.20 metres (8") from every point on the surface of the fitting.

• Maximum ambient temperature

Do not use the projector if ambient temperature (t_a) exceeds 40°C.

• IP20 protection rating

The protection rating of the fitting is IP20. The meaning of the protection rating is:

IP 2 0

└ Not protected against dripping water, rain, splashes or jets of water.

└ Protected against penetration by solid bodies of over 12mm (0.47") in diameter.

• Protection against electrical shock

Connection must be made to a power supply system fitted with efficient earthing (Class I appliance according to standard EN 60598-1). It is, moreover, recommended to protect the supply lines of the projectors from indirect contact and/or shorting to earth by using appropriately sized residual current devices.

• Connection to the power mains

A qualified electrician must perform connection to the power mains. Check that the mains frequency and voltage correspond to the frequency and voltage for which the projector was designed and indicated on the electrical data label. This label also gives the input power. Refer to the latter to evaluate the maximum number of devices to be connected to the mains to avoid overloads.

The user must determine, in consultation with the supply authority, that the equipment is connected only to a supply with a maximum permissible system impedance Z_{max} , at the interface point of the user's supply, equal or lower to 0.23 Ω .

• External surface temperature

The maximum temperature that can be reached on the external surface of the fitting, in a thermally steady state, is 100°C (212°F).

• Maintenance

Before starting any maintenance work or cleaning the projector, cut off power from the supply mains. After switching off, do not remove any parts of the fitting for at least 10 minutes. The cover must be mounted and, if visibly damaged, they have to be replaced with genuine spares.

• Photobiological Safety

CAUTION. Do not look directly at the light source.

Do not look at the light beam with optical devices or any other tool that could cause light convergence.

• This product is intended for the following areas of application: studios, stages, theaters, exhibitions, trade fairs, events, theme parks, entertainment venues, architectural lighting and similar.

• **Not suitable for household illumination.**

• **Not for residential use.**

• Disposing

This product is supplied in compliance with European Directive 2012/19/EU - Waste Electrical and Electronic Equipment (WEEE). To preserve the environment please dispose/recycle this product at the end of its life according to the local regulation.

The products to which this manual refers comply with the European Directives pursuant to:

- 2014/35/EU - Safety of electrical equipment supplied at low voltage (LVD)
- 2014/30/EU - Electromagnetic Compatibility (EMC)
- 2011/65/EU - Restriction of the use of certain hazardous substances (RoHS)
- 2009/125/EC - EcoDesign requirements for Energy-related Products (ErP)

EN

How to get your SAFETY INSTRUCTIONS in multilingual version

You may always download the multilingual Safety Instruction manual for this Clay Paky product from:

<http://www.claypaky.it/en/download>

Ref: [FIS00N – Safety Information Stormy / Stormy CC]

IT

Come ottenere le INFORMAZIONI DI SICUREZZA nella versione multilingue

Puoi sempre scaricare la versione multilingue delle Informazioni di Sicurezza per questo prodotto Clay Paky al seguente link:

<http://www.claypaky.it/en/download>

Rif: [FIS00N – Safety Information Stormy / Stormy CC]

DE

So erhalten Sie Ihr INFORMATIONEN ZUR SICHERHEIT in der mehrsprachigen Version

Sie können die mehrsprachige Version des Handbuchs mit Sicherheitshinweisen für dieses Clay Paky-Produkt unter folgendem Link herunterladen:

<http://www.claypaky.it/en/download>

Ref: [FIS00N – Safety Information Stormy / Stormy CC]

ES

Cómo obtener tu INFORMACIONES DE SEGURIDAD en la versión multilingüe

Siempre puedes descargar la versión multilingüe del Manual de Instrucciones de Seguridad para este producto Clay Paky en el siguiente enlace

<http://www.claypaky.it/en/download>

Ref: [FIS00N – Safety Information Stormy / Stormy CC]

FR

Comment obtenir votre CONSIGNES DE SÉCURITÉ dans la version multilingue

Vous pouvez toujours télécharger la version multilingue du Manuel d'Instructions de Sécurité pour ce produit Clay Paky

au lien suivant :

<http://www.claypaky.it/en/download>

Réf. : [FIS00N – Safety Information Stormy / Stormy CC]

RU

Где достать ИНСТРУКЦИЮ ПО ТЕХНИКЕ БЕЗОПАСНОСТИ на нескольких языках

Вы всегда можете скачать многоязычную инструкцию по технике безопасности для данного изделия Clay Paky по ссылке:

<http://www.claypaky.it/en/download>

Наименование: [FIS00N – Safety Information Stormy / Stormy CC]

2. UNPACKING AND PREPARATION

1

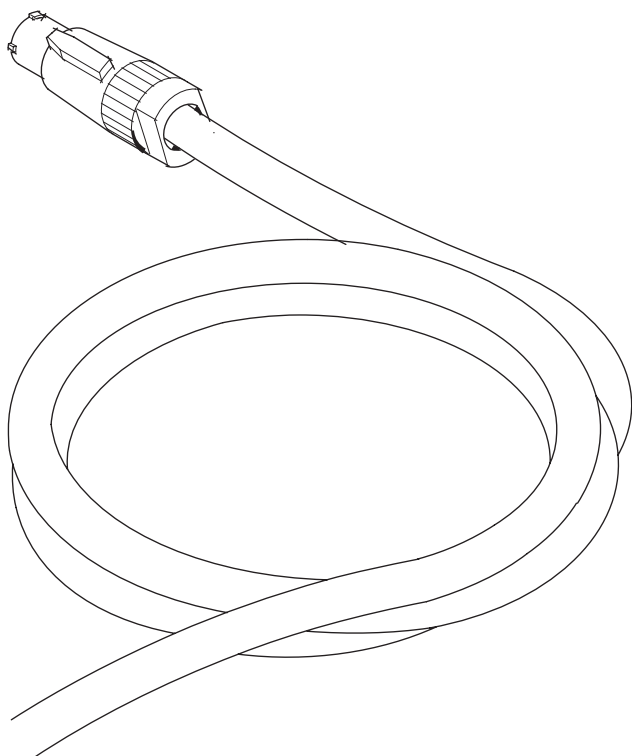

Fig. 1 - Packing content

3. INSTALLATION AND START-UP

2

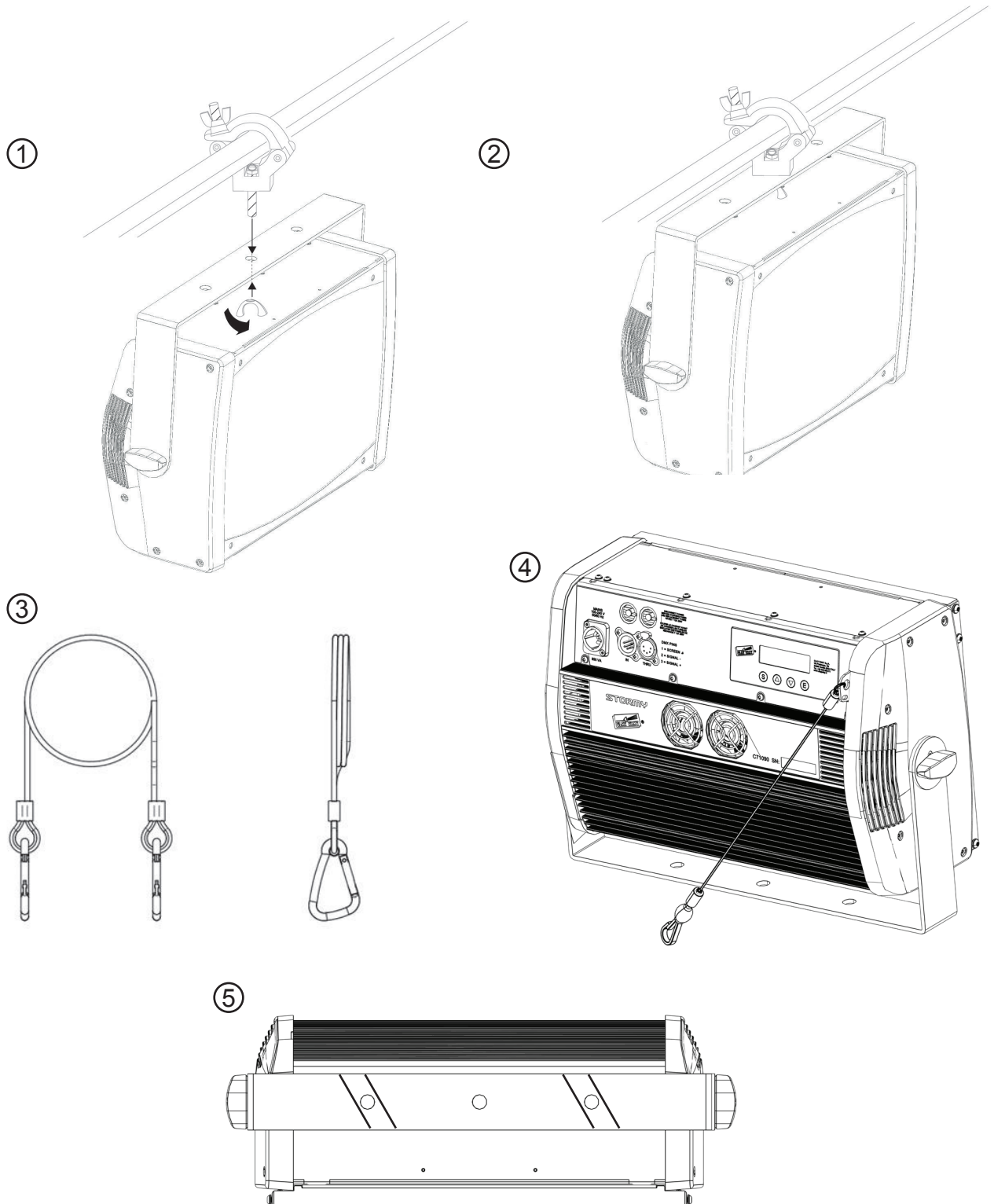

Fig. 2 - Projector installation

The projector can be installed on the floor, on a truss, on the ceiling or wall. **WARNING: the safety chain must be installed except when the projector rests on the floor. (Code 105015/801 available upon request). This must be secured to the projector support structure and then hooked to the fastening point at the centre of the fixture.**

3. INSTALLATION AND START-UP

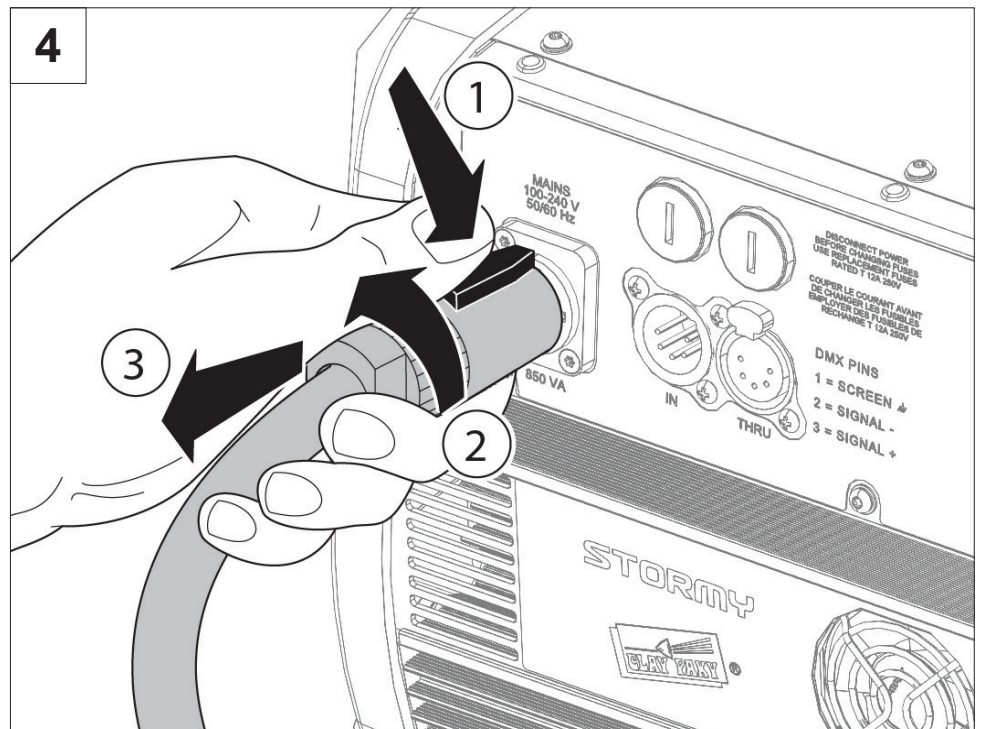
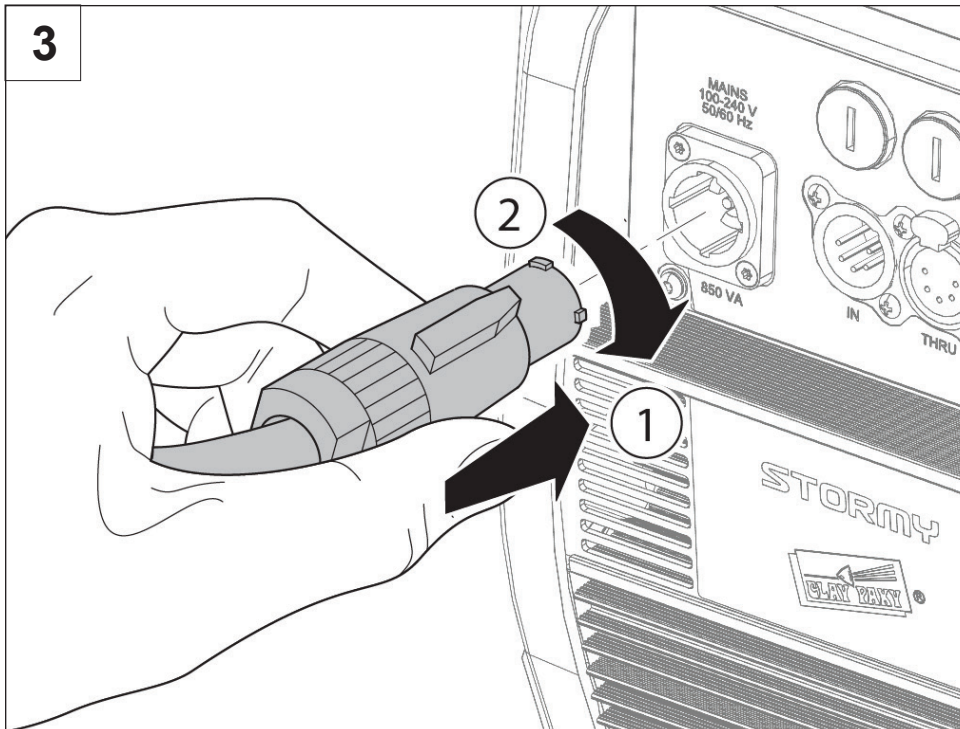
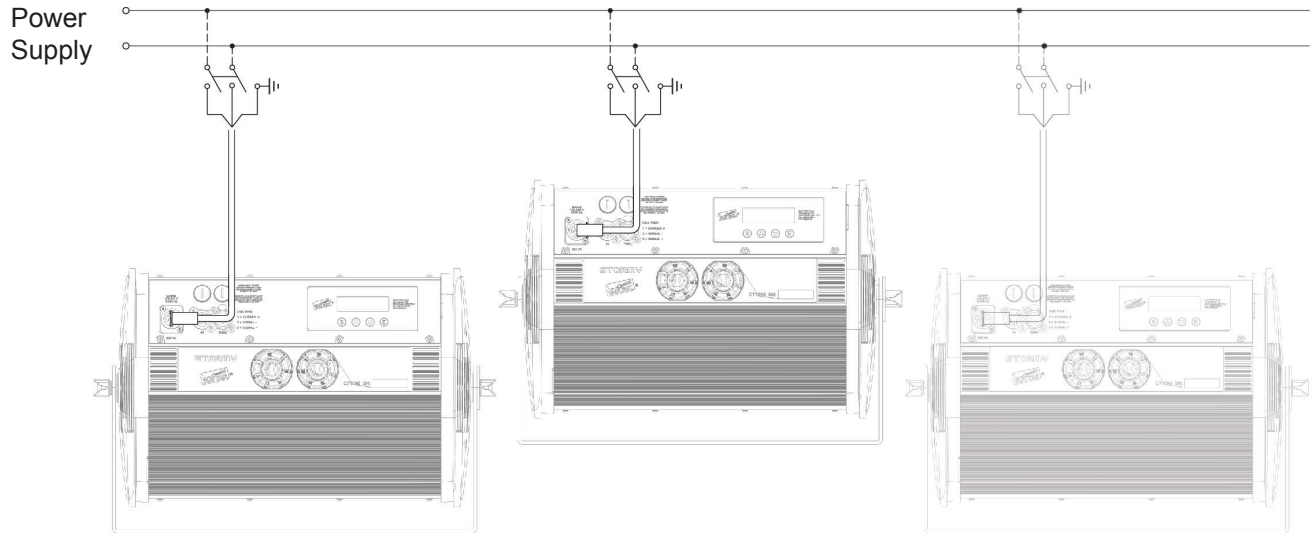

Fig. 3, 4 - Connecting and disconnecting the power cord

4. CONTROL PANEL

5



6

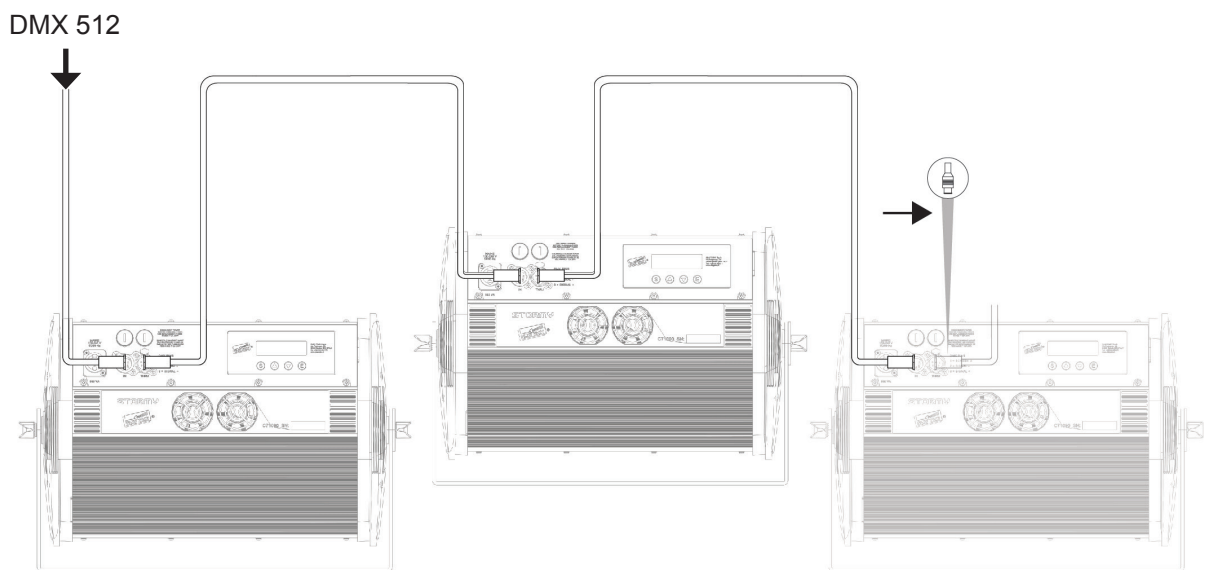

DMX 512
5 PIN

Fig. 5 - Connection to the power mains

Fig. 6 - Connections to the control signal line (DMX)

Use a cable conforming to specifications EIA RS-485: 2-pole twisted, shielded, 120Ω characteristic impedance, 22-24 AWG, low capacity. Do not use microphone cable or other cable with characteristics differing from those specified. End connections must be made using XLR type 3-pin male/female connectors. A terminating plug must be inserted on the last projector with a resistance of 120 (minimum 1/4 W) between terminals 2 and 3.

IMPORTANT: The wires must not make contact with each other or with the metal casing of the connectors. The casing must be connected to the shield braid and pin 1 of the connectors.

4. CONTROL PANEL

7







Menu settings status

If no button is pressed after a wait period (about 60 seconds) → the display automatically returns to idle status.

Any modified value that has not yet been confirmed with the E key will be cancelled.

Button functions – Menu SET

<p>SELECT</p> 	<ul style="list-style-type: none"> • If pressed in idle status: Cyclically switches between idle status and menu settings. • If pressed while setting a menu: Moves to an upper level without changing anything (exits the function)
<p>DOWN</p> 	<p>Decreases the value displayed (with auto-repetitions), or passes to the next item on the menu. For quick access to the minimum parameter value, press the UP key while holding down the DOWN key.</p>
<p>UP</p> 	<p>Increases the value displayed (with auto-repetitions), or passes to the previous item on the menu. For quick access to the maximum parameter value, press the DOWN key while holding down the UP key.</p>
<p>ENTER</p> 	<p>Confirms the displayed value or activates the displayed function or opens the next menu.</p>

Display inversion

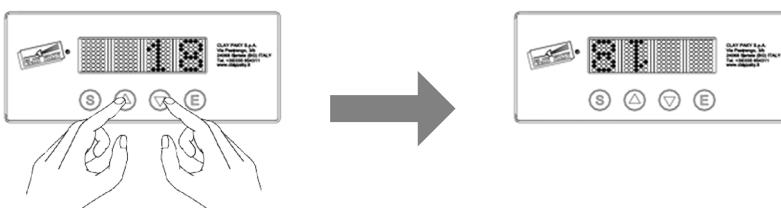

To activate this function press at the same time UP and DOWN keys while the display is in standby.

The condition is memorized and saved even for the subsequent switching. To return to the initial state repeat the operation again.

Fig. 7 - Switching on the projector

The projector immediately turns on when the power cord is plugged

5. MENU SETTING

Main Menu	Level 1	Level 2	Level 3	Choices / Values
SET UP	DMX Address			001-512
	Channel Mod	Standard		
		Xenon		
		Idependent		
Extended				
Fixture ID			001-255	
OPTION	Dimmer Curve	Curve 1		
		Curve 2		
	Minimum Ton Value			000-255
	LED mode (Stormy CC only)	Raw		
		Balance		
	Silent Mode	Standard		
		Quiet		
	Display			On / Off
	Settings	Default preset	Reset to default	Yes / No
		User preset 1	Load preset 1	Yes / No
			Save to preset 1	Yes / No
User preset 2		Load preset 2	Yes / No	
		Save to preset 2	Yes / No	
User preset 3		Load preset 3	Yes / No	
	Save to preset 3	Yes / No		
INFORMATION	Fixture hours	Total		
		Partial		
	System Version	Strobe firmware		
		Boot firmware		
		Driver firmware		
		CPU board		
		CPU SN		
	Driver diagnostic	LED Temperature	Current	
			Maximum	
			Minimum	
		Driver Temperature	Current	
			Maximum	
			Minimum	
	LED channel		CH1 - CH4 (R-G-B-W)	
	DMX Monitor	Red		000-255bit / 0-100%
Green			000-255bit / 0-100%	
Blue			000-255bit / 0-100%	
White			000-255bit / 0-100%	
Intensity			000-255bit / 0-100%	
Duration			000-255bit / 0-100%	
Rate			000-255bit / 0-100%	
Fans Monitor	Head		Speed xxxx RPM	
MANUAL CONTROL	Reset		Yes / No	
	Channel	Red		000-255bit / 0-100%
		Green		000-255bit / 0-100%
		Blue		000-255bit / 0-100%
		Whjite		000-255bit / 0-100%
		Intensity		000-255bit / 0-100%
		Duration		000-255bit / 0-100%
Rate		000-255bit / 0-100%		
ADVANCED	Access Code <u>1234</u>	Firmware uploader		Yes / No
		Model SetUp	Undefined mode	
			Stormy	
	Stormy CC			

5.1 SET-UP MENU

SET UP - DMX ADDRESS

It allows to set DMX address to be assigned to the projector, it's possible to select a DMX address between 1 and 512.

> **NOTE:** In case of absence of DMX input signal, the displayed projector address flashes.

SET UP - CHANNEL MODE

It allows to set the operation mode of the projector selecting from the following:

- **Standard:** max 7 DMX channels occupied for "Stormy CC" / max 3 DMX channels occupied for "Stormy".
 - **Xenon:** max 4 DMX channels occupied for "Stormy"
 - **Independent:** max 14 DMX channels for "Stormy CC"
 - **Extended:** max 15 DMX channels for "Stormy CC"
-

SET UP - FIXTURE ID

It allows to set a "Fixture ID" to be assigned to the projector, for easier identification of the same projector in an installation. It's possible to select a "Fixture ID" between 1 and 255.

5.2 OPTIONS MENU

OPTION - DIMMER CURVE

It allows the selection of one of the following two Dimmer curves:

- **Curve 1**
 - **Curve 2**
-

OPTION - MINIMUM TON VALUE

It allows to set the minimum "**T ON**" duration of strobe flash under which it's not possible to come down. It's possible to select a value between 0 and 255.

With the "**Duration**" channel you set the flash duration. At every level of the DMX signal corresponds a duration. The value "**Minimum T ON value**" represents the level of the DMX channel **Duration** under which the TON value does not change.

OPTION - LED MODE

It allows the selection of one of the following two methods of LEDs management

- **Row:** RGBW channels are independent.
 - **Balance:** RGBW components are optimized to have a white color with maximum light output.
-

OPTION - SILENT MODE

It allows the selection of one of the following two alternatives:

- **Standard:** Maximum fans' speed; therefore maximum noise level and maximum light output of the LEDs.
- **Quiet:** It reduces the fans' speed and, as a consequence, the noise; the maximum brightness of the LEDs. It reduces also subject to decrease according to the conditions of use (ambient temperature, used effect type).

OPTIONS - **DISPLAY**

The enabled DISPLAY option (ON) allows to reduce the display backlight on the machine, after a 30 seconds in standby mode. To restart is enough to press any key. Select OFF to disable this option.

OPTIONS - **SETTING**

It allows to save in the machine memory 3 different settings of the options menu items and its submenus:

- **User preset 1**
- **User preset 2**
- **User preset 3**

- **Load preset 1, 2 o 3:** It is used to display a previously configuration saved by the user.

- **Save to preset 1, 2 o 3:** It is used to save the current configuration set by the user.

- **Default preset**

It allows to reset to the default values (factory settings) on all the voices of the option menu and of the related submenus.

5.3 INFORMATION MENU

INFORMATION MENU - **FIXTURE HOURS**

It allows to display the projector operating hours (total and partial).

Total hours: it counts the number of projector working life hours (from manufacture to date).

Partial hours: it counts the number of partial projector working life hours since the last reset up to date.

Press **ENTER** to reset partial projector working life hours, a confirmation message (Are you sure ?) appears on the display. Select **YES** to confirm the cancellation.

INFORMATION MENU - **SYSTEM VERSION**

It allows to display the firmware/hardware versions of installed machine components:

Strobe firmware: Strobe application firmware

Boot firmware: Safety software

Driver firmware: Driver application firmware

CPU board: Hardware revision of CPU Board

CPU SN: Serial number of CPU Board

INFORMATION MENU - DRIVER DIAGNOSTIC - **LED TEMPERATURE**

It allows to display some details about the functionality of the card/cards and LEDs:

- **Current:** Instantly detected operating temperature
 - **Maximum:** Maximum detected temperature
 - **Minimum:** Minimum detected temperature
-

INFORMATION MENU - DRIVER DIAGNOSTIC - **DRIVER TEMPERATURE**

It allows to view some details about the functionality of the driver card for LED:

- **Current:** Instantly detected operating temperature
 - **Maximum:** Maximum detected temperature
 - **Minimum:** Minimum detected temperature
-

INFORMATION MENU - DRIVER DIAGNOSTIC - **LED CHANNEL**

It displays the diagnostics from the driver card: for each of the 4 channels a SYSTEM information and a ERROR information is reported (the decoding is specified in the driver's specifications).

INFORMATION MENU - **DMX MONITOR**

It allows to visualize the DMX input level (in bits or as a percentage) of each channel of the projector (value Between 0 and 255 bit or between 0 and 100%).

INFORMATION MENU - **FANS MONITOR**

It allows to display the rotation speed (**RPM Speed**) of the fans installed on the machine.
Head = Power Supply fans.

5.4 MANUAL CONTROL MENU

MANUAL CONTROL - **RESET**

It allows to reset the projector's CPU in case of anomalies.

MANUAL CONTROL - **CHANNEL**

It allows to set a value in bit to the channels, from the projector control panel for manual control of each effect without the need of a DMX input signal (values between 0 and 255 bits).

5.5 ADVANCED MENU

To access to the Advanced menu (only recommended for experienced users), you need to set the access code 1234.

ADVANCED MENU - **FIRMWARE UPLOAD**

It allows to transfer the firmware from one projector to the others connected to it.

ADVANCED MENU - **MODEL SETUP**

It allows to change the projector's model set, selecting among the available:

- **Undefined**
- **Stormy**
- **Stormy CC**

6. MAINTENANCE

8

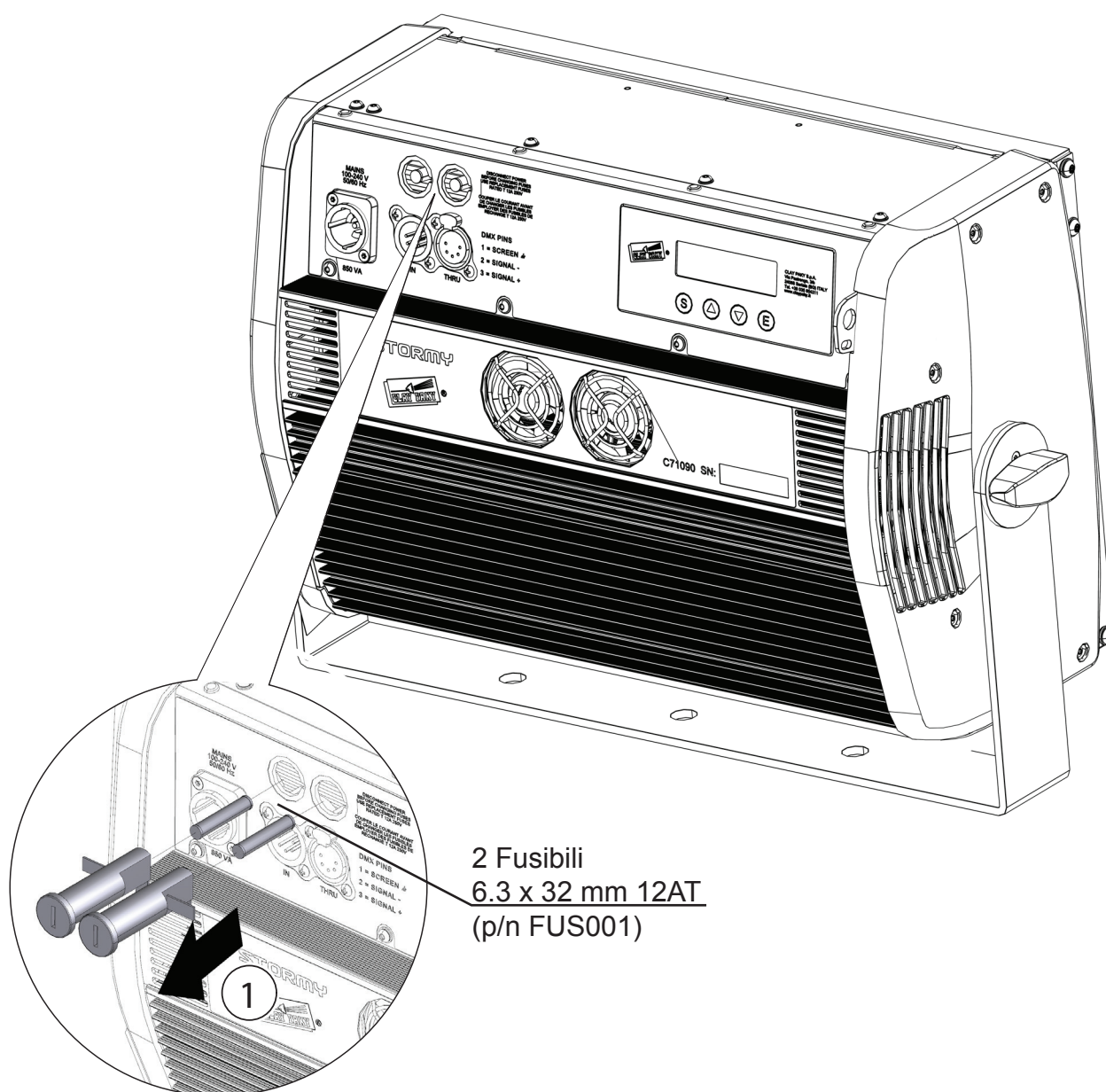

Fig. 8 - Fuses replacing

Each product has 2 fuses associated with the main power cord connection.

6. MAINTENANCE

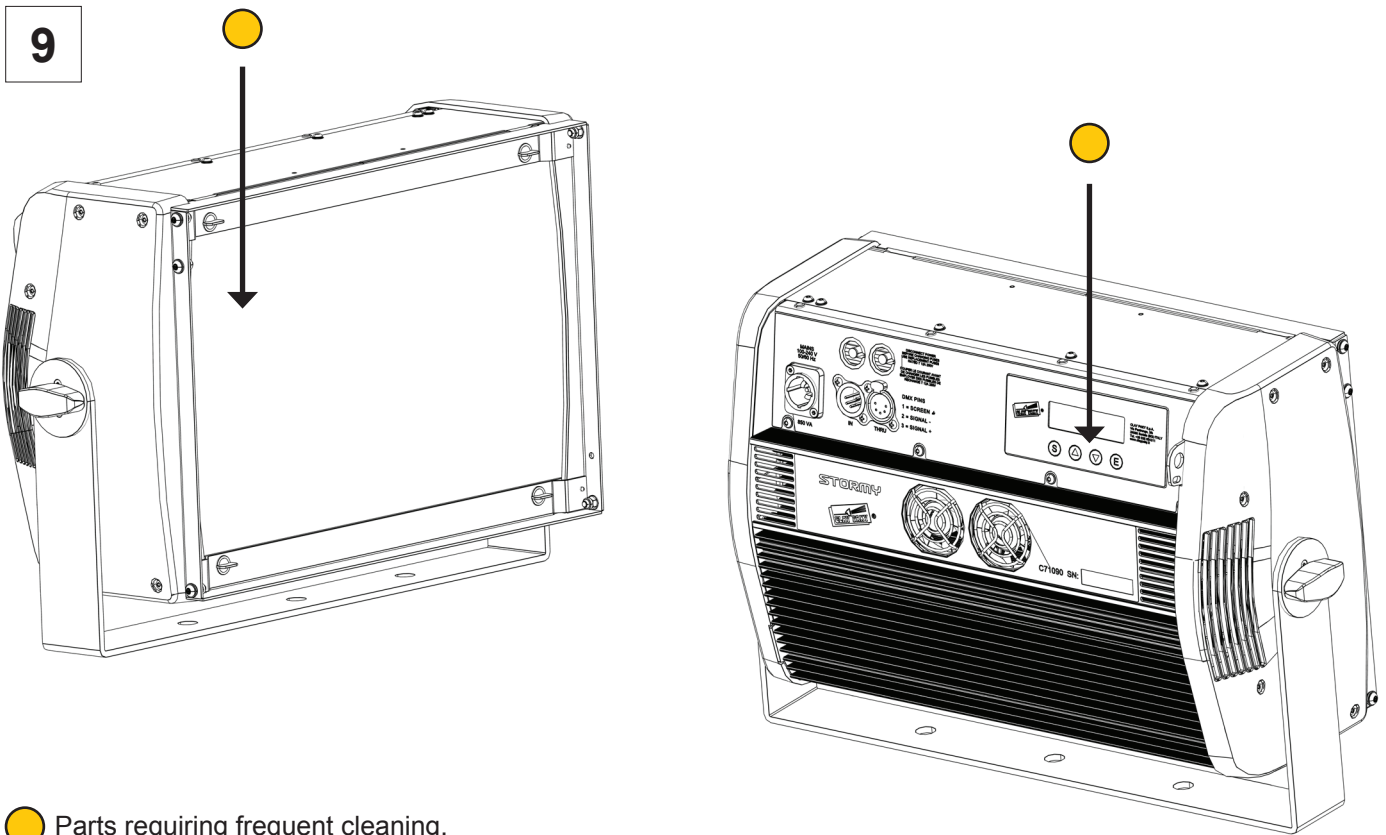

Fig. 9 - Periodic cleaning

To ensure optimal operation and performance for a long time it is essential to periodically clean the parts subject to dust and grease deposits. The frequency with which the following operations are to be carried out depends on various factors such as wear and the work environment quality (air humidity, dust, salinity, etc.). To remove dirt from external parts, use a soft cloth dampened with any liquid glass cleaning detergent.

It is recommended that the projector undergoes an annual service by a qualified technician for special maintenance involving at least the following operations:

- General cleaning of internal parts.
- General visual check of internal parts, cabling, mechanical parts, etc.
- Electrical, photometric and functional checks; eventual repairs.

IMPORTANT: Cleaning transparent cover

Only use neutral soap and water to clean the transparent cover then dry it carefully with a soft, non-abrasive cloth. (WARNING: the use of alcohol or any other detergent could damage the transparent cover.)

7. ACCESSORIES

10

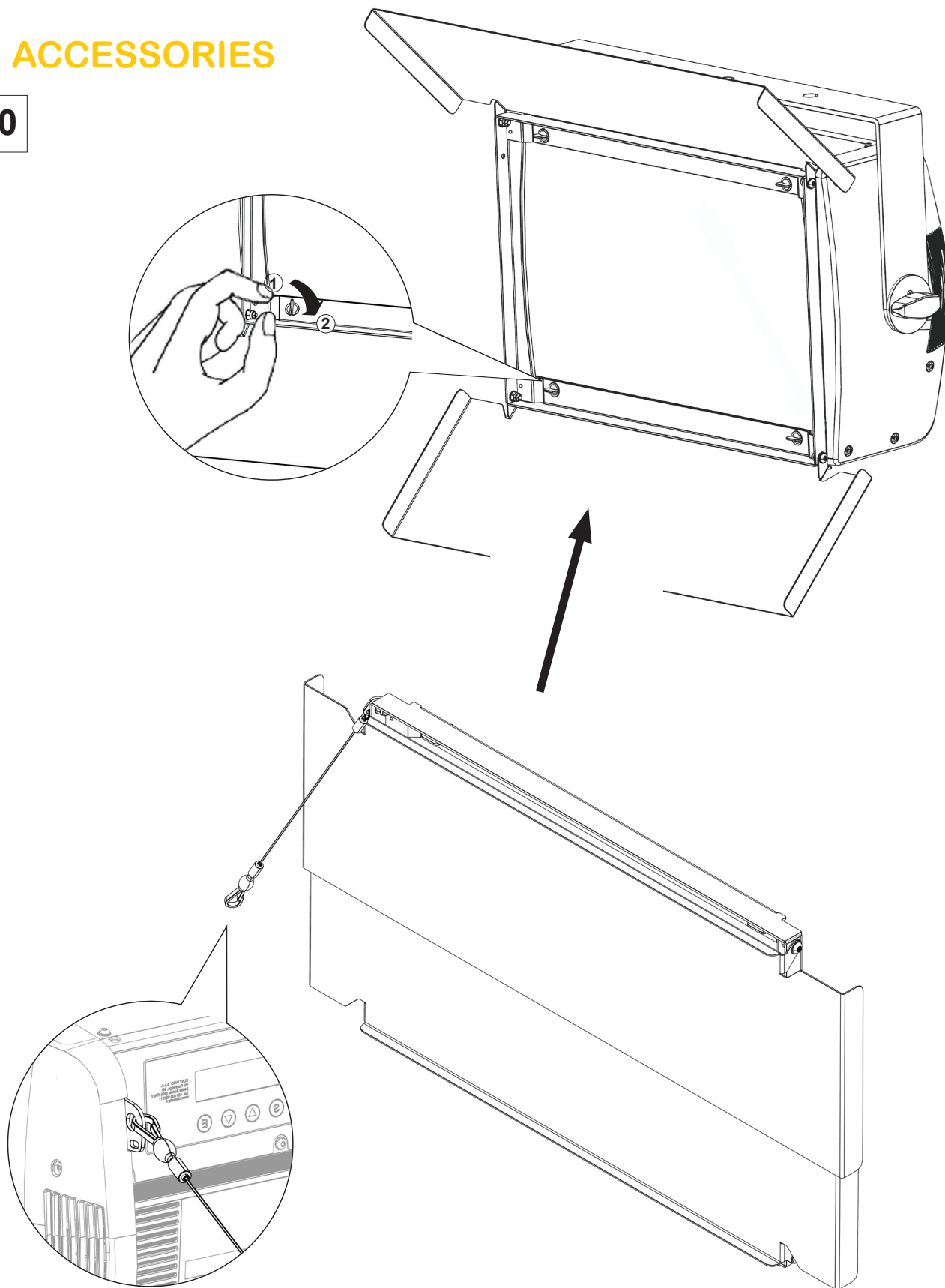

Fig. 10 - Barn-doors - C71116

8.1/A TECHNICAL DATA _ STORMY

POWER SUPPLIES	100/240V 50/60 Hz Automatic power supply
INPUT POWER	850 VA
TOTAL LUMEN OUTPUT	Max 80.000 lm
LIGHT SOURCE	144x8W(peak power) LED White - Type: OSRAM OSOLON SQUARE LED - GW CSSRM1.PC - Color Temperature: 5.700 K - Life: 50.000 hrs - Luminous flux: 60.000 lm (continuous), 80.000 lm (peak)
CHANNELS	3 channels DMX 512 Standard mode 4 channels DMX 512 Xenon mode
CONTROL INPUTS	DMX 512
WEIGHT	7,5 Kg (15,87 lbs)
IP RATING	IP20 Protected against the entry of solid bodies larger than 12mm (0,47") No protection against the entry of liquids
SAFETY DEVICES	Automatic shut-down in case of power supply overcurrent Automatic power derating, in case of LED or power supply overheating or failed operation of cooling system
COOLING	Forced ventilation with fans and heat sink
BODY	Body extruded in black anodized aluminum Aluminum and steel structure with plastic covers
WORKING POSITION	Any working position Hanging system: with clamps on the bracket
OPTICS	42° controlled light 130° direct + controlled light
COLOR SYSTEM AND EFFECTS SECTION	Global dimmer Strobe from 0,3 to 25 flashes/sec Xenon lamp emulation Extended range of macros
CONTROL AND PROGRAMMING	DMX protocol signal: USITT DMX 512 Display: Graphic LCD , backlit LED, white on black Dimmer Resolution: 8 bit Strobe 25Hz DMX signal connection: 5 pole XLR input and output Software upload through DMX input
ELECTRONICS	Electronic monitoring with status error Active Cooling system monitoring DMX level monitoring on all channels Internal data transmission diagnostics Firmware upload from another fixture

8.1/B TECHNICAL DATA _ STORMY CC

POWER SUPPLIES	100/240V 50/60 Hz Automatic power supply
INPUT POWER	850 VA
TOTAL LUMEN OUTPUT	Max 40.000 lm
LIGHT SOURCE	36x6W (peak power) LED - Type: OSRAM OSOLON SIGNAL 120 - RED - LJ CKBP-JXKZ-27-1 36x7W (peak power) LED - Type: OSRAM OSOLON SIGNAL 120 - GREEN - LT CQBP-KYLX-36-1 36x8W (peak power) LED - Type: OSRAM OSOLON SQUARE LED - BLUE - LD CQAR-APAR-24-1 36x8W (peak power) LED - Type: OSRAM OSOLON SQUARE LED - WHITE - GW CSSRM1.PC - Color Temperature: 5.700 K - Life: 50.000 hrs - Luminous flux: 25.000 lm (continuous), 35.000 lm (peak)

CHANNELS	7 channels DMX 512 Standard mode 15 channels DMX 512 Extended mode 14 channels DMX 512 Independent mode (to come)
CONTROL INPUTS	DMX 512
WEIGHT	7,5 Kg (15,87 lbs)
IP RATING	IP20 Protected against the entry of solid bodies larger than 12mm (0,47") No protection against the entry of liquids
SAFETY DEVICES	Automatic shut-down in case of power supply overcurrent Automatic power derating, in case of LED or power supply overheating or failed operation of cooling system
COOLING	Forced ventilation with fans and heat sink
BODY	Body extruded in black anodized aluminum Aluminum and steel structure with plastic covers
WORKING POSITION	Any working position Hanging system: with clamps on the bracket
OPTICS	42° controlled light 130° direct + controlled light
COLOR SYSTEM AND EFFECTS SECTION	Global dimmer Strobe from 0,3 to 25 flashes/sec Xenon lamp emulation Extended range of macros Independent timing controls for each color
CONTROL AND PROGRAMMING	DMX protocol signal: USITT DMX 512 Display: Graphic LCD, backlit LED, white on black Dimmer Resolution: 8 bit Strobe 25Hz DMX signal connection: 5 pole XLR input and output Software upload through DMX input
ELECTRONICS	Electronic monitoring with status error Active Cooling system monitoring DMX level monitoring on all channels Internal data transmission diagnostics Firmware upload from another fixture

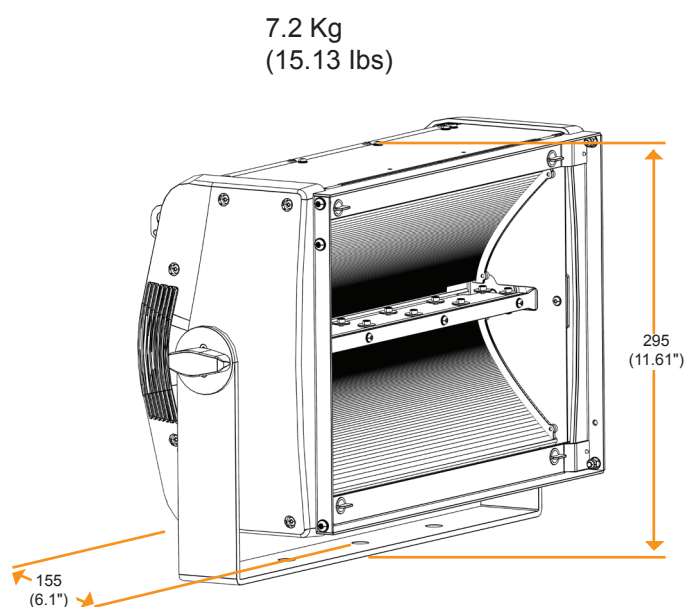
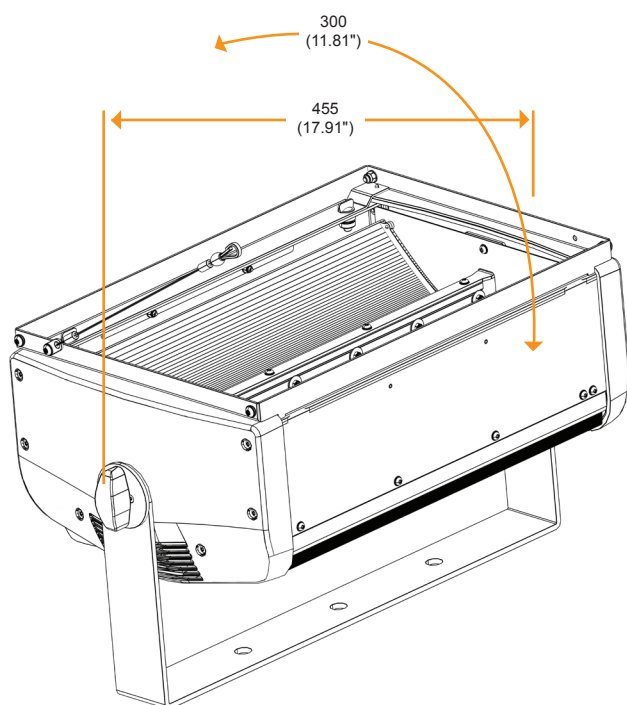

STORMY - CHANNEL LIST

CHANNEL	CHANNEL MODE	
	STANDARD	XENON
1	INTENSITY	INTENSITY
2	DURATION	DURATION
3	RATE	RATE
4	-	MACRO

STORMY - CHANNEL FUNCTION

Channel Mode		DMX Value	Function
Standard	Xenon		
1	1		INTENSITY
		0 - 5	Light OFF
		6 - 255	Light output linearly increase from minimum to maximum brightness
2	2		DURATION
		0 - 255	Light time (versus dark time) linearly increases from shorter time (2.5msec) to longer time (650msec) <i>See details in a following dedicated table.</i> IMPORTANT: Duration Time must be lower than Rate Time (Period) for flashing. If Duration Time is equal or greater than Rate Time (Period) the light is continuously on.
3	3		RATE
		0 - 5	Light OFF
		6 - 255	Flashing at linearly variable frequency from low: (~0.3 flashes/sec or 1 flash every period of 3.5sec) to high (25 flashes/sec or 1°flash every period of 40msec) <i>See details in a following dedicated table.</i>
-	4		MACRO
		0 - 5	Macro OFF
		6 - 42	Macro 1 – UP ramp
		43 - 85	Macro 2 – DOWN ramp
		86 - 128	Macro 3 - UP↔DOWN ramp
		129 - 171	Macro 4 – Random
		172 - 214	Macro 5 – Lightning
215 - 255	Macro 6 – Spikes		

STORMY CC - CHANNEL LIST

CHANNEL	CHANNEL MODE		
	STANDARD	INDEPENDENT	EXTENDED
1	RED INTENSITY	RED INTENSITY	RED FOREGROUND
2	GREEN INTENSITY	RED DURATION	GREEN FOREGROUND
3	BLUE INTENSITY	RED RATE	BLUE FOREGROUND
4	WHITE INTENSITY	GREEN INTENSITY	WHITE FOREGROUND
5	MASTER INTENSITY	GREEN DURATION	DIMMER FOREGROUND
6	MASTER DURATION	GREEN RATE	MASTER DURATION
7	MASTER RATE	BLUE INTENSITY	MASTER RATE
8	-	BLU DURATION	MACRO t.b.d
9	-	BLU RATE	OFFSET t.b.d
10	-	WHITE INTENSITY	FUNCTION
11	-	WHITE DURATION	RED BACKGROUND
12	-	WHITE RATE	GREEN BACKGROUND
13	-	MASTER INTENSITY	BLUE BACKGROUND
14	-	MASK	WHITE BACKGROUND
15	-	-	DIMMER BACKGROUND

STORMY CC - “STANDARD” CHANNEL FUNCTION

Channel Mode	DMX Value	Function
Standard		
1		RED INTENSITY
	0 - 255	Red colour linearly increase from no-light to maximum intensity
2		GREEN INTENSITY
	0 - 255	Green colour linearly increase from no-light to maximum intensity
3		BLUE INTENSITY
	0 - 255	Blue colour linearly increase from no-light to maximum intensity
4		WHITE INTENSITY
	0 - 255	White colour linearly increase from no-light to maximum intensity
5		MASTER INTENSITY
	0 - 5	No Light output
	6 - 255	Light output linearly increase from minimum to maximum brightness
6		MASTER DURATION
	0 - 255	Light time (versus dark time) linearly increases from shorter time (2.5msec) to longer time (650msec) <i>See details in a following dedicated table.</i> IMPORTANT: Duration Time must be lower than Rate Time (Period) for flashing. If Duration Time is equal or greater than Rate Time (Period) the light is continuously on.
7		MASTER RATE
	0 - 5	Light OFF
	6 - 255	Flashing at linearly variable frequency from low: (~0.3 flashes/sec or 1 flash every period of 3.5sec) to high (25 flashes/sec or 1°flash every period of 40msec). <i>See details in a following dedicated table.</i>

STORMY CC - "INDIPENDENT" CHANNEL FUNCTION

Channel Mode	DMX Value	Function
1		RED INTENSITY
	0 - 255	Red colour linearly increase from no-light to maximum intensity
2		RED DURATION
	0 - 255	Light time (versus dark time) linearly increases from shorter time (2.5msec) to longer time (650msec) <i>See details in a following dedicated table.</i> IMPORTANT: Duration Time must be lower than Rate Time (Period) for flashing. If Duration Time is equal or greater than Rate Time (Period) the light is continuously on.
3		RED RATE
	0 - 5	Single Dimmer flash
	6 - 255	Flashing at linearly variable frequency from low: (~0.3 flashes/sec or 1 flash every period of 3.5sec) to high (25 flashes/sec or 1°flash every period of 40msec). <i>See details in a following dedicated table.</i>
4		GREEN INTENSITY
	0 - 255	Green colour linearly increase from no-light to maximum intensity
5		GREEN DURATION
	0 - 255	Light time (versus dark time) linearly increases from shorter time (2.5msec) to longer time (650msec) <i>See details in a following dedicated table.</i> IMPORTANT: Duration Time must be lower than Rate Time (Period) for flashing. If Duration Time is equal or greater than Rate Time (Period) the light is continuously on.
6		GREEN RATE
	0 - 5	Single Dimmer flash
	6 - 255	Flashing at linearly variable frequency from low: (~0.3 flashes/sec or 1 flash every period of 3.5sec) to high (25 flashes/sec or 1°flash every period of 40msec) <i>See details in a following dedicated table.</i>
7		BLUE INTENSITY
	0 - 255	Blue colour linearly increase from no-light to maximum intensity
8		BLUE DURATION
	0 - 255	Light time (versus dark time) linearly increases from shorter time (2.5msec) to longer time (650msec) <i>See details in a following dedicated table.</i> IMPORTANT: Duration Time must be lower than Rate Time (Period) for flashing. If Duration Time is equal or greater than Rate Time (Period) the light is continuously on.
9		BLUE RATE
	0 - 5	Single Dimmer flash
	6 - 255	Flashing at linearly variable frequency from low: (~0.3 flashes/sec or 1 flash every period of 3.5sec) to high (25 flashes/sec or 1°flash every period of 40msec). <i>See details in a following dedicated table.</i>

Continued →

Channel Mode	DMX Value	Function
Independent		
10		WHITE INTENSITY
	0 - 255	White colour linearly increase from no-light to maximum intensity
11		WHITE DURATION
	0 - 255	Light time (versus dark time) linearly increases from shorter time (2.5msec) to longer time (650msec) <i>See details in a following dedicated table.</i> IMPORTANT: Duration Time must be lower than Rate Time (Period) for flashing. If Duration Time is equal or greater than Rate Time (Period) the light is continuously on
12		WHITE RATE
	0 - 5	Single Dimmer flash
12	6 - 255	Flashing at linearly variable frequency from low: (~0.3 flashes/sec or 1 flash every period of 3.5sec) to high (25 flashes/sec or 1°flash every period of 40msec) <i>See details in a following dedicated table.</i>
		MASTER INTENSITY
13	0 - 5	No Light output
	6 - 255	<i>Light output linearly increase from minimum to maximum brightness</i>
14		MASK
	0-31	No overwriting
	32-47	RED overwrites all other channels
	48-63	GREEN overwrites all other channels
	64-79	BLUE overwrites all other channels
	80-95	WHITE overwrites all other channels
	96-111	RED, GREEN overwrite BLUE, WHITE
	112-127	RED, BLUE overwrite GREEN, WHITE
	128-143	RED, WHITE overwrite GREEN, BLUE
	144-159	GREEN, BLUE overwrite RED, WHITE
	160-175	GREEN, WHITE overwrite RED, BLUE
	176-191	BLUE, WHITE overwrite RED, GREEN
	192-207	RED, GREEN, BLUE overwrite WHITE
	208-223	RED, GREEN, WHITE overwrite BLUE
224-239	RED, BLUE, WHITE overwrite GREEN	
240-255	GREEN, BLUE, WHITE overwrite RED	

STORMY CC - "EXTENDED" CHANNEL FUNCTION

Channel Mode	DMX Value	Function
Extended		
1		RED FOREGROUND
	0 - 255	Red Foreground Colour linearly increase from no-light to maximum intensity
2		GREEN FOREGROUND
	0 - 255	Green Foreground Colour linearly increase from no-light to maximum intensity
3		BLUE FOREGROUND
	0 - 255	Blue Foreground Colour linearly increase from no-light to maximum intensity
4		WHITE FOREGROUND
	0 - 255	White Foreground Colour linearly increase from no-light to maximum intensity
5		DIMMER FOREGROUND
	0 - 5	No Light output
	6 - 255	Light output linearly increase from minimum to maximum brightness
6		MASTER DURATION
	0 - 255	Light time (versus dark time) linearly increases from shorter time (2.5msec) to longer time (650msec) <i>See details in a following dedicated table.</i> IMPORTANT: Duration Time must be lower than Rate Time (Period) for flashing. If Duration Time is equal or greater than Rate Time (Period) the light is continuously on.
7		MASTER RATE
	0 - 5	Light OFF
	6 - 255	Flashing at linearly variable frequency from low: (~0.3 flashes/sec or 1 flash every period of 3.5sec) to high (25 flashes/sec or 1°flash every period of 40msec) <i>See details in a following dedicated table.</i>
8		MACRO
	0 - 255	T.B.D.
9		OFFSET
	0 - 255	T.B.D.
10		FUNCTION
	0 - 9	Foreground overwrite Background (Xenon mode)
	10 - 19	Foreground + Background (Xenon mode)
	20 - 29	Foreground overwrite Background (Continuous mode)
	30 - 39	Foreground + Background (Continuous mode)
11		RED BACKGROUND
	0 - 255	Red Background Colour linearly increase from no-light to maximum intensity
12		GREEN BACKGROUND
	0 - 255	Green Background Colour linearly increase from no-light to maximum intensity

Channel Mode	DMX Value	Function
Extended		
13		BLUE BACKGROUND
	0 - 255	Blue Background Colour linearly increase from no-light to maximum intensity
14		WHITE BACKGROUND
	0 - 255	White Background Colour linearly increase from no-light to maximum intensity
15		DIMMER BACKGROUND
	0 - 5	No Light output
	6 - 255	Light output linearly increase from minimum to maximum brightness

9.3 DURATION CHANNEL DETAILS

DMX level	Time [msec]	DMX level	Time [msec]	DMX level	Time [msec]	DMX level	Time [msec]	DMX level	Time [msec]	DMX level	Time [msec]
0	2.50	43	111.7	86	220.8	129	330.0	172	439.2	215	548.4
1	5.00	44	114.2	87	223.4	130	332.6	173	441.7	216	550.9
2	7.60	45	116.7	88	225.9	131	335.1	174	444.3	217	553.5
3	10.10	46	119.3	89	228.5	132	337.6	175	446.8	218	556.0
4	12.60	47	121.8	90	231.0	133	340.2	176	449.4	219	558.5
5	15.20	48	124.4	91	233.5	134	342.7	177	451.9	220	561.1
6	17.70	49	126.9	92	236.1	135	345.3	178	454.4	221	563.6
7	20.30	50	129.4	93	238.6	136	347.8	179	457.0	222	566.2
8	22.80	51	132.0	94	241.2	137	350.3	180	459.5	223	568.7
9	25.30	52	134.5	95	243.7	138	352.9	181	462.1	224	571.2
10	27.90	53	137.1	96	246.2	139	355.4	182	464.6	225	573.8
11	30.40	54	139.6	97	248.8	140	358.0	183	467.1	226	576.3
12	33.00	55	142.1	98	251.3	141	360.5	184	469.7	227	578.9
13	35.50	56	144.7	99	253.9	142	363.0	185	472.2	228	581.4
14	38.00	57	147.2	100	256.4	143	365.6	186	474.8	229	583.9
15	40.60	58	149.8	101	258.9	144	368.1	187	477.3	230	586.5
16	43.10	59	152.3	102	261.5	145	370.7	188	479.8	231	589.0
17	45.70	60	154.8	103	264.0	146	373.2	189	482.4	232	591.6
18	48.20	61	157.4	104	266.6	147	375.7	190	484.9	233	594.1
19	50.70	62	159.9	105	269.1	148	378.3	191	487.5	234	596.6
20	53.30	63	162.5	106	271.6	149	380.8	192	490.0	235	599.2
21	55.80	64	165.0	107	274.2	150	383.3	193	492.5	236	601.7
22	58.30	65	167.5	108	276.7	151	385.9	194	495.1	237	604.2
23	60.90	66	170.1	109	279.2	152	388.4	195	497.6	238	606.8
24	63.40	67	172.6	110	281.8	153	391.0	196	500.1	239	609.3
25	66.00	68	175.1	111	284.3	154	393.5	197	502.7	240	611.9
26	68.50	69	177.7	112	286.9	155	396.0	198	505.2	241	614.4
27	71.00	70	180.2	113	289.4	156	398.6	199	507.8	242	616.9
28	73.60	71	182.8	114	291.9	157	401.1	200	510.3	243	619.5
29	76.10	72	185.3	115	294.5	158	403.7	201	512.8	244	622.0
30	78.70	73	187.8	116	297.0	159	406.2	202	515.4	245	624.6
31	81.20	74	190.4	117	299.6	160	408.7	203	517.9	246	627.1
32	83.70	75	192.9	118	302.1	161	411.3	204	520.5	247	629.6
33	86.30	76	195.5	119	304.6	162	413.8	205	523.0	248	632.2
34	88.80	77	198.0	120	307.2	163	416.4	206	525.5	249	634.7
35	91.40	78	200.5	121	309.7	164	418.9	207	528.1	250	637.3
36	93.90	79	203.1	122	312.3	165	421.4	208	530.6	251	639.8
37	96.40	80	205.6	123	314.8	166	424.0	209	533.2	252	642.3
38	99.00	81	208.2	124	317.3	167	426.5	210	535.7	253	644.9
39	101.5	82	210.7	125	319.9	168	429.1	211	538.2	254	647.4
40	104.1	83	213.2	126	322.4	169	431.6	212	540.8	255	650.0
41	106.6	84	215.8	127	325.0	170	434.1	213	543.3		
42	109.1	85	218.3	128	327.5	171	436.7	214	545.8		

9.4 RATE CHANNEL DETAILS

DMX level	Time [msec]	Frequency [flash/sec]
0	-	0
1	-	0
2	-	0
3	-	0
4	-	0
5	-	0
6	3500	0.29
7	3500	0.29
8	2320	0.43
9	2320	0.43
10	1760	0.57
11	1760	0.57
12	1400	0.71
13	1400	0.71
14	1160	0.86
15	1160	0.86
16	1000	1.00
17	1000	1.00
18	880.0	1.14
19	880.0	1.14
20	760.0	1.32
21	740.0	1.35
22	720.0	1.39
23	700.0	1.43
24	640.0	1.56
25	600.0	1.67
26	580.0	1.72
27	570.0	1.75
28	560.0	1.79
29	540.0	1.85
30	500.0	2.00
31	490.0	2.04
32	480.0	2.08
33	460.0	2.17
34	440.0	2.27
35	430.0	2.33
36	420.0	2.38
37	410.0	2.44
38	400.0	2.50
39	390.0	2.56
40	384.0	2.60
41	376.0	2.66
42	360.0	2.78

DMX level	Time [msec]	Frequency [flash/sec]
43	350.0	2.86
44	336.0	2.98
45	330.0	3.03
46	320.0	3.13
47	315.0	3.17
48	310.0	3.23
49	305.0	3.28
50	300.0	3.33
51	290.0	3.45
52	284.0	3.52
53	280.0	3.57
54	275.0	3.64
55	270.0	3.70
56	264.0	3.79
57	255.0	3.92
58	250.0	4.00
59	245.0	4.08
60	240.0	4.17
61	237.0	4.22
62	234.0	4.27
63	231.0	4.33
64	227.0	4.41
65	224.0	4.46
66	220.0	4.55
67	217.0	4.61
68	214.0	4.67
69	211.0	4.74
70	208.0	4.81
71	205.0	4.88
72	200.0	5.00
73	197.5	5.06
74	195.0	5.13
75	192.5	5.19
76	190.0	5.26
77	187.5	5.33
78	185.0	5.41
79	182.5	5.48
80	180.0	5.56
81	178.0	5.62
82	176.0	5.68
83	174.0	5.75
84	172.0	5.81
85	170.0	5.88

DMX level	Time [msec]	Frequency [flash/sec]
86	168.0	5.95
87	166.0	6.02
88	164.0	6.10
89	162.0	6.17
90	160.0	6.25
91	158.0	6.33
92	156.0	6.41
93	154.0	6.49
94	152.0	6.58
95	151.0	6.62
96	150.0	6.67
97	149.0	6.71
98	148.0	6.76
99	147.0	6.80
100	146.0	6.85
101	145.0	6.90
102	144.0	6.94
103	142.0	7.04
104	140.0	7.14
105	138.0	7.25
106	136.0	7.35
107	134.0	7.46
108	132.0	7.58
109	130.0	7.69
110	128.0	7.81
111	127.0	7.87
112	126.0	7.94
113	125.0	8.00
114	124.0	8.06
115	123.0	8.13
116	122.0	8.20
117	121.0	8.26
118	120.0	8.33
119	119.0	8.40
120	118.0	8.47
121	117.0	8.55
122	116.0	8.62
123	115.0	8.70
124	114.0	8.77
125	113.0	8.85
126	112.0	8.93
127	111.0	9.01
128	110.0	9.09

9.4 RATE CHANNEL DETAILS

DMX level	Time [msec]	Frequency [flash/sec]
129	109.0	9.17
130	110.0	9.09
131	109.5	9.13
132	109	9.17
133	108.5	9.22
134	108.0	9.26
135	107.5	9.30
136	107.0	9.35
137	106.5	9.39
138	106.0	9.43
139	105.5	9.48
140	105.0	9.52
141	104.5	9.57
142	104.0	9.62
143	103.0	9.71
144	102.0	9.80
145	101.0	9.90
146	100.0	10.00
147	99.0	10.10
148	98.0	10.20
149	97.0	10.31
150	96.0	10.42
151	95.0	10.53
152	94.0	10.64
153	93.0	10.75
154	92.0	10.87
155	91.0	10.99
156	90.0	11.11
157	89.5	11.17
158	89.0	11.24
159	88.5	11.30
160	88.0	11.36
161	87.5	11.43
162	87.0	11.49
163	86.5	11.56
164	86.0	11.63
165	85.5	11.70
166	85.0	11.76
167	84.5	11.83
168	84.0	11.90
169	83.5	11.98
170	83.0	12.05
171	82.5	12.12
172	82.0	12.20

DMX level	Time [msec]	Frequency [flash/sec]
173	81.5	12.27
174	81.0	12.35
175	80.5	12.42
176	80.0	12.50
177	79.6	12.56
178	79.2	12.63
179	78.8	12.69
180	78.4	12.76
181	78.0	12.82
182	77.6	12.89
183	77.2	12.95
184	76.8	13.02
185	76.4	13.09
186	76.0	13.16
187	75.6	13.23
188	75.2	13.30
189	74.8	13.37
190	74.4	13.44
191	74.0	13.51
192	73.6	13.59
193	73.2	13.66
194	72.8	13.74
195	72.4	13.81
196	72.0	13.89
197	71.6	13.97
198	71.2	14.04
199	70.8	14.12
200	70.4	14.20
201	70.0	14.29
202	69.6	14.37
203	69.2	14.45
204	69.0	14.49
205	68.7	14.56
206	68.4	14.62
207	68.1	14.68
208	67.8	14.75
209	67.5	14.81
210	67.2	14.88
211	66.9	14.95
212	66.6	15.02
213	66.3	15.08
214	66.0	15.15
215	65.7	15.22
216	65.4	15.29

DMX level	Time [msec]	Frequency [flash/sec]
217	65.1	15.36
218	64.8	15.43
219	64.5	15.50
220	64.2	15.58
221	63.9	15.65
222	63.6	15.72
223	63.3	15.80
224	63.0	15.87
225	62.7	15.95
226	62.4	16.03
227	62.1	16.10
228	61.8	16.18
229	61.5	16.26
230	61.2	16.34
231	60.9	16.42
232	60.6	16.50
233	60.3	16.58
234	60.0	16.67
235	59.0	16.95
236	58.0	17.24
237	57.0	17.54
238	56.0	17.86
239	55.0	18.18
240	54.0	18.52
241	53.0	18.87
242	52.0	19.23
243	51.0	19.61
244	50.0	20.00
245	49.0	20.41
246	48.0	20.83
247	47.0	21.28
248	46.0	21.74
249	45.0	22.22
250	44.0	22.73
251	43.0	23.26
252	42.0	23.81
253	41.0	24.39
254	40.0	25.00
255	40.0	25.00

10. DURATION time - RATE time (PERIOD) relation

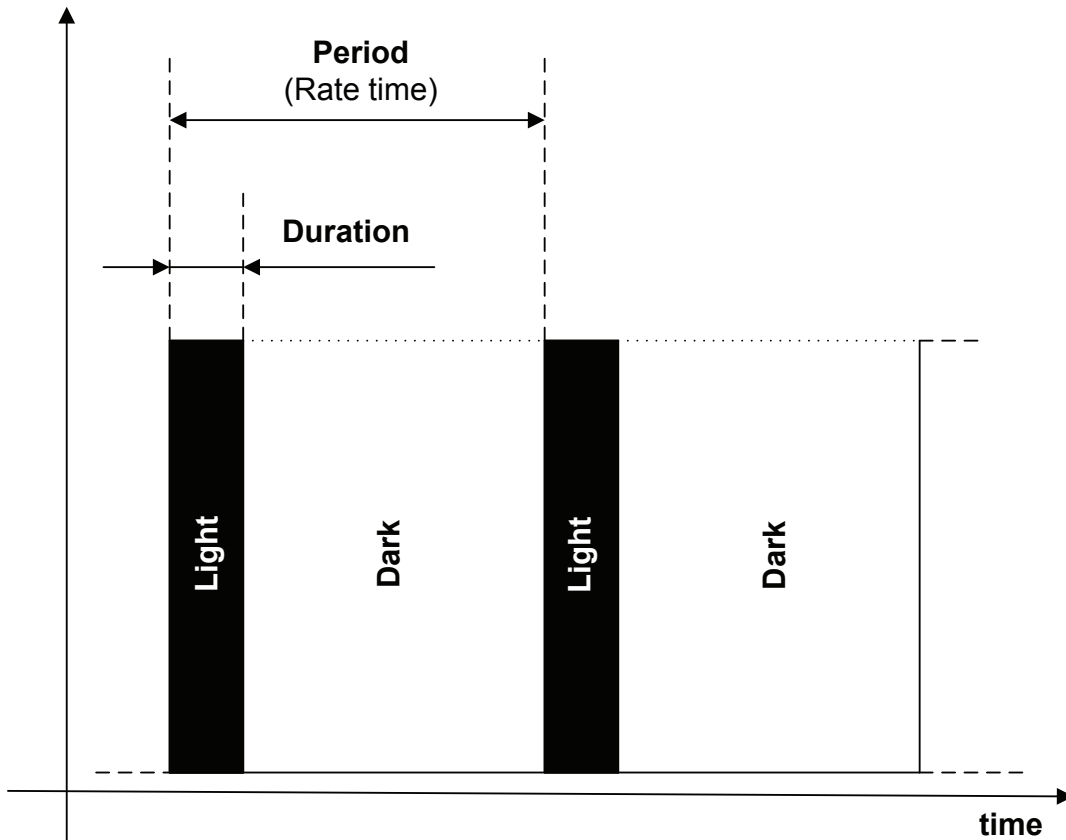

Duration time < Period : Flashing
Duration time >= Period : Light continuously ON

